

THE **ORIENTAL INSTITUTE**
1998-1999
ANNUAL REPORT

Cover and Title page Illustration: Detail of King Tutankhamun statue in the Joseph and Mary Grimshaw Egyptian Gallery. Photograph by Jean Grant

The pages that divide the sections of this year's report feature photographs of the installation of the Joseph and Mary Grimshaw Egyptian Gallery

Editor: Gene Gragg

Production Editor: Emily Napolitano

Printed by United Graphics Incorporated, Mattoon, Illinois

The Oriental Institute, Chicago

Copyright 1999 by The University of Chicago. All rights reserved.

Published 1999. Printed in the United States of America.

CONTENTS

INTRODUCTION	1
INTRODUCTION. <i>Gene Gragg</i>	3
IN MEMORIAM	5
ARCHAEOLOGY	7
AMUQ VALLEY REGIONAL PROJECT. <i>K. Aslihan Yener and Tony J. Wilkinson</i>	9
TELL BEYDAR SURVEY. <i>Tony J. Wilkinson</i>	18
BIR UMM FAWAKHIR. <i>Carol Meyer</i>	25
DHAMAR PROJECT. <i>Tony J. Wilkinson</i>	37
DIYALA OBJECTS PROJECT. <i>McGuire Gibson</i>	42
EPIGRAPHIC SURVEY. <i>W. Raymond Johnson</i>	46
GIZA. <i>Mark Lehner</i>	66
HADIR QINNASRIN. <i>Donald Whitcomb</i>	76
JOINT PREHISTORIC PROJECT. <i>Robert J. Braidwood and Linda S. Braidwood</i>	83
NIPPUR AND UMM AL-HAFRIYAT. <i>McGuire Gibson</i>	85
TELL ES-SWEYHAT. <i>Thomas A. Holland</i>	88
PHILOLOGY	97
CHICAGO ASSYRIAN DICTIONARY. <i>Martha T. Roth</i>	99
CHICAGO HITTITE DICTIONARY. <i>Harry A. Hoffner, Jr.</i>	100
DEMOTIC DICTIONARY PROJECT. <i>Stephen Vinson</i>	101
RESEARCH	105
INDIVIDUAL RESEARCH	107
COMPUTER LABORATORY. <i>John C. Sanders and Peggy M. Sanders</i>	124
PUBLICATIONS. <i>Thomas A. Holland</i>	130
RESEARCH ARCHIVES. <i>Charles E. Jones</i>	132
MUSEUM	137
MUSEUM. <i>Karen L. Wilson</i>	139
MUSEUM EDUCATION. <i>Carole Krucoff</i>	144
VOLUNTEER PROGRAM. <i>Catherine Dueñas and Terry Friedman</i>	158
SUQ. <i>Denise Browning</i>	172
DEVELOPMENT	173
DEVELOPMENT. <i>Tim Cashion</i>	175
VISITING COMMITTEE TO THE ORIENTAL INSTITUTE	179
LEGACY CAMPAIGN EXECUTIVE COMMITTEE	179
HONOR ROLL OF MEMBERS AND DONORS	181
STAFF OF THE ORIENTAL INSTITUTE	231
INFORMATION	236



INTRODUCTION

Overleaf: The Persian bull in an uninstalled gallery looks serenely down on the Egyptian Gallery cases prior to their installation in the Grimshaw Gallery. Photograph by Jean Grant

INTRODUCTION

Gene Gragg

In a flurry of other activity that marked this year, an important milestone has gone pretty much unremarked — the eightieth anniversary of the Oriental Institute. Yes, May 1999 did in fact mark the eightieth anniversary of an institution that was born in May 1919. In the spring of that year a challenge was issued by James Henry Breasted, in a paper delivered at the Philadelphia meeting of the American Oriental Society, about the creation of a new kind of research institute, one that would combine the most up-to-date field, instrumental, and text-linguistic methods into what should be, in his words, a veritable “research laboratory for the investigation of the early human career.” In May, he received a letter from John D. Rockefeller, Jr. His challenge had been taken up. The funding would be available. Could he make good?

The subsequent history of the Oriental Institute marks the paths that have been taken to realize Breasted’s vision. And as I look back over the year narrated in this report, my strongest impression is that of a turning of a major corner in the path we are now engaged on. An unprecedented fund-raising effort, the Legacy Campaign, has been brought to a conclusion; a gallery, the Joseph and Mary Grimshaw Egyptian Gallery, has been opened, and a plan of attack is about to be revealed for the remaining four; archaeologists and museum staff have settled into new laboratory and work spaces; remaining building improvements are on deck; the Oriental Institute enjoys an uncommon level of public interest and support. But the most important thing is research. New knowledge about the ancient Near East is what we have always been about, and as we prepare for the transition into a new century and millennium we do so on a momentum of research activity on all fronts. You can read about this in the pages that follow. I believe that the future is full of promise.

In archaeology we are (almost) all over the map in and near many of the places that have seen Oriental Institute activity over the past eighty years. A wide range of field expeditions are underway. In Turkey, Aslihan Yener and the Amuq Valley Regional Project team have been making discoveries in sixth- to fifth-millennium levels at Tell Kurdu, while the associated survey has pushed the site total in that valley up to 239 — a total that includes some of the most important Bronze Age sites for potential excavation. In Syria, Tony Wilkinson’s Beydar survey has uncovered a revealing pattern of settlement, desertion, and reoccupation which bolsters theories of Bronze Age nomadization in that area, while at the other end of the Oriental Institute’s chronological scale Don Whitcomb has been laying bare some crucial evidence for early Islamic urbanization in Qinnasrin. In Egypt, Ray Johnson and the Chicago House crew continued a remarkable seventy-five year long string of sea-

INTRODUCTION

sons, opening up a new area of Medinet Habu in the process, in a season whose visitor list included the First Lady and daughter; east of Luxor, Carol Meyer's Bir Umm Fawakhir discoveries, when analyzed, will round off our understanding of that Byzantine/Coptic mining town. Also from Egypt, Mark Lehner's Giza project once again appears in our pages, and will be reported on regularly.

On the home front, archaeological scholarship also goes on when the digging stops (or is temporarily interrupted). In these pages you can see what Oriental Institute archaeologists have discovered in Roman Tell es-Sweyhat (Syria), Bronze Age Dhamar (Yemen), and in the Diyala, Nippur, and Umm-al-Hafriyat (Iraq). Exciting things are about to happen in the world of dictionaries. You will be hearing more about these in future editions of this report, but for the moment you can read about the steady progress of the *Chicago Hittite Dictionary*, and how the *Demotic Dictionary* and, that flagship of Oriental Institute projects, the *Chicago Assyrian Dictionary* are closing in on their goals. All of these efforts rely heavily, as always, on the research environment provided by the Computer Laboratory and the Research Archives.

Finally, this year of course has been the year of the reinstallation of the Egyptian Gallery. Karen Wilson (and photographs scattered throughout this report) reveals the story behind this capital event, and the accompanying reports give a sense of the transforming effect of this on our Museum Education and Volunteer Programs (a record volunteer class this year!).

This past year has indeed been one of activity, change, and new beginnings. The faculty and staff have prepared the Oriental Institute for the new millennium. I only hope you will continue to journey with us through the next millennium and beyond.

IN MEMORIAM**Henrietta M. Herbolsheimer****1913–1999**

Trained as a physician at the University of Chicago Medical School in the 1930s, Hank devoted her life to the care of others as teacher, clinician, and public health pioneer. She brought the same exacting standards from her medical career to her advocacy for the Institute; we are better off for having known her.

Maurice D. Schwartz**1913–1999**

From his days as a student at the Institute in the 1930s, Maury was deeply committed to education, both in Near Eastern studies and more generally. A longtime member of the Oriental Institute Visiting Committee, he followed all the Institute's activities with an acute but supportive eye. His passing is a deep personal loss to many in the Institute family.



ARCHAEOLOGY

Overleaf: After moving King Tutankhamun statue, workers in north gallery remove part of wall behind an Assyrian relief in order to move the relief. Photograph by Jean Grant

AMUQ VALLEY REGIONAL PROJECT

K. Aslihan Yener and Tony J. Wilkinson

The Oriental Institute Amuq Valley Regional Project (AVRP) commenced full-scale excavations at Tell Kurdu, one of the 237 sites in the Amuq Plain. This approximately 15 ha site is situated close to the eastern edge of the former Amuq Lake (Lake Antioch-Amik Gölü) in the southernmost part of Turkey, the State of Hatay. The site was previously excavated by Oriental Institute teams, including Robert Braidwood in a rapid two week season in 1938. Full scale operations were resumed this year from 22 August to 12 October 1998 with a team of twenty-five, including students from the University of Chicago's Department of Near Eastern Languages and Civilizations. The excavations were embedded within the overarching aim to reconstruct palaeoenvironment and landscape patterns. Survey efforts wrapped up the first phase of reconnaissance in the valley and included parts of the foothills and mountain ranges of the Amanus.

The 1998 season was conducted under the auspices of the Turkish Ministry of Culture, Directorate General of Monuments and Museums. In Ankara we were greatly assisted by the Acting General Director of Monuments and Museums, Kenan Yurttagül. The Ministry was represented by Mehmet Erdem from the Antakya Museum. The 1998 excavation team consisted of Aslihan Yener (project director), Chris Edens (site director), Abbas Alizadeh, Jesse Casana, Benjamin Diebold, Bakiye Yükmén, and Kubra Ensert. Brenda Craddock and Tülin Arslanoğlu executed the illustrations, Paul Zimmerman the topographical survey. Heidi Ekstrom, Missy Loyet, and David Reese were responsible for the palaeobotany and faunal analyses. Tania Collas and Cap Sease were the site conservators. A separate survey team led by Tony Wilkinson consisted of Tim Harrison, Jan Verstraete, Simrit Dhesi, Shin Ishiyama, Hatice Pamir, and Tülin Arslanoğlu. They continued the geoarchaeological and archaeological survey of the Amuq Valley and conducted additional surveys in the foothills. The Amuq Valley Regional Project was funded by the National Geographic Society, the Oriental Institute, Kress Foundation, and numerous private donors. We are particularly grateful to both the Oriental Institute and its members who contributed financially to the success of the project. Special thanks go to Malcolm H. Wiener and the Institute of Aegean Prehistory for their continuing support of the Amuq Valley Regional Project.

Excavations at Tell Kurdu (K. A. Yener)

The season began with the creation of a set of topographical maps of Tell Kurdu and endangered neighboring sites such as Tell 'Imar and Tell Dhahab near Judaidah. Tell Kurdu dates from Amuq Phases C through E (sixth–fifth millennium BC), and care was given to expose horizontally as much of Phase E as possible and to target known burials. Ten trenches of various sizes were placed on the northern and southern sectors of Tell Kurdu. Trenches 1, 6, and 9 exposed 225 m² on the summit of the

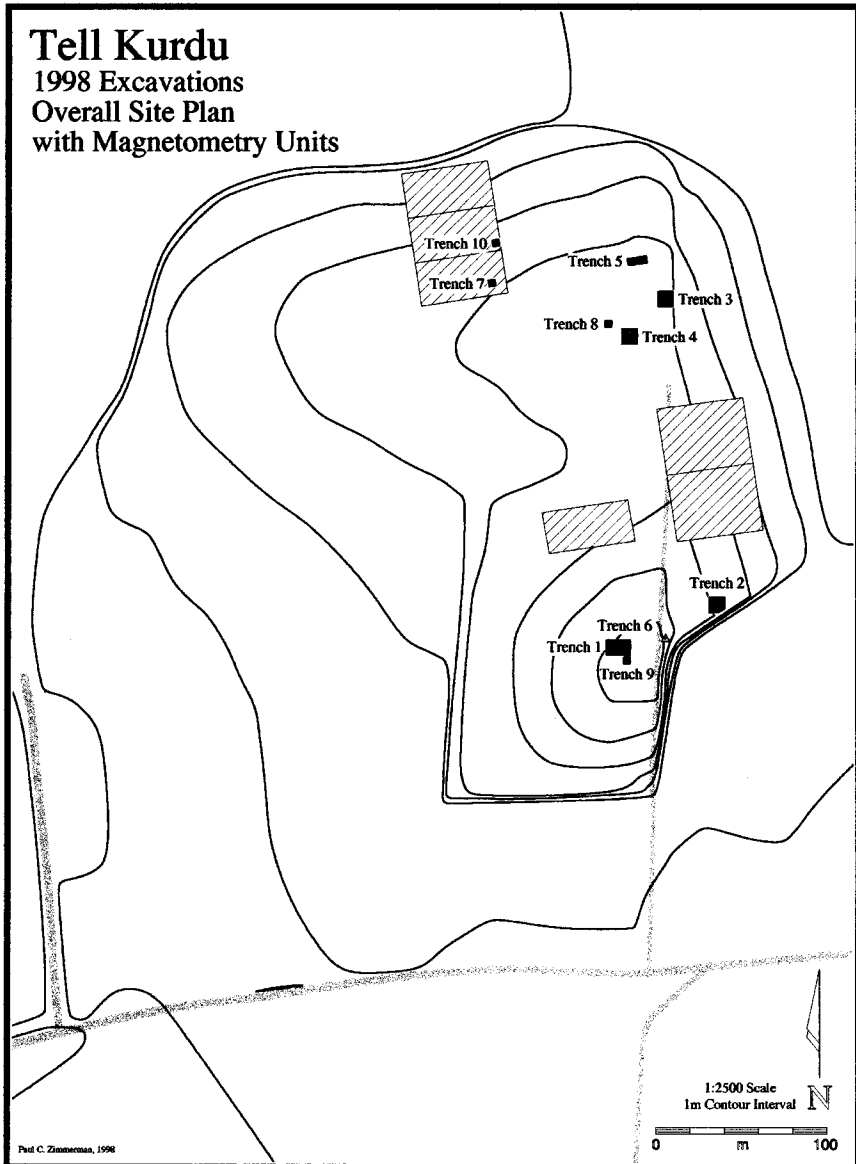

Figure 1. Tell Kurdu topographical map

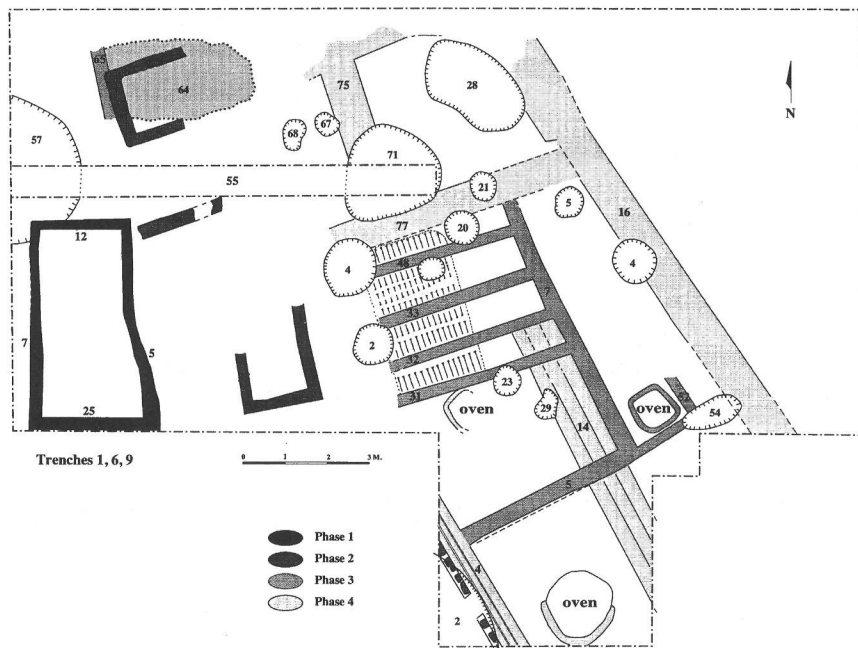

Figure 2. Trenches 1, 6, and 9

Southern Mound and unearthed a large multi-room building made of pisé slabs immediately below the plow zone. Long, narrow grill-like storage rooms flank a rectilinear corridor and subsidiary rooms of this public building set on a terrace. The terrace was constructed of alternating packed mud and reeds and provided a large open space adjacent to the building to the west. Undulating reed bedding, laid horizontally like beams, was found partly covering the base of the storage rooms – a curious and difficult to understand architectural idiom. Pottery revealed that the structure dates to very early Amuq Phase E or transitional Amuq Phase D/E, in the late sixth or very early fifth millennium BC.

Trench 2, which exposed 100 m² on the eastern edge and yielded a building with an array of pisé storage bins constructed like pigeonholes, is slightly later in date. An earlier phase yielded a large pisé tholos building (roughly 7 m in diameter) with triangular internal buttresses. Normally tholoi are associated with the Halaf period; however, the pottery retrieved from the floor was consistent with Phase E Ubaid traditions.

Trenches 3, 4, 5, 7, 8, and 10 exposed 335 m² on the older Northern Mound where an Ubaid cemetery had been reported by locals in previous years, and older deposits with architecture were targeted. Several flexed burials were found in situ with grave goods cut into a complicated sequence of midden deposits in Trench 4, filled chockablock with discarded charred grain and burnt pisé lumps. Catfish the size of a table, baby elephant, lion, equid, and other wild fauna were dumped into the trash pits that are tentatively dated to Phase D. Trench 7 exposed multi-room architecture with a cremation burial placed sometime after the use of the building. Associated pottery resembles Halaf Phases C and D periods.

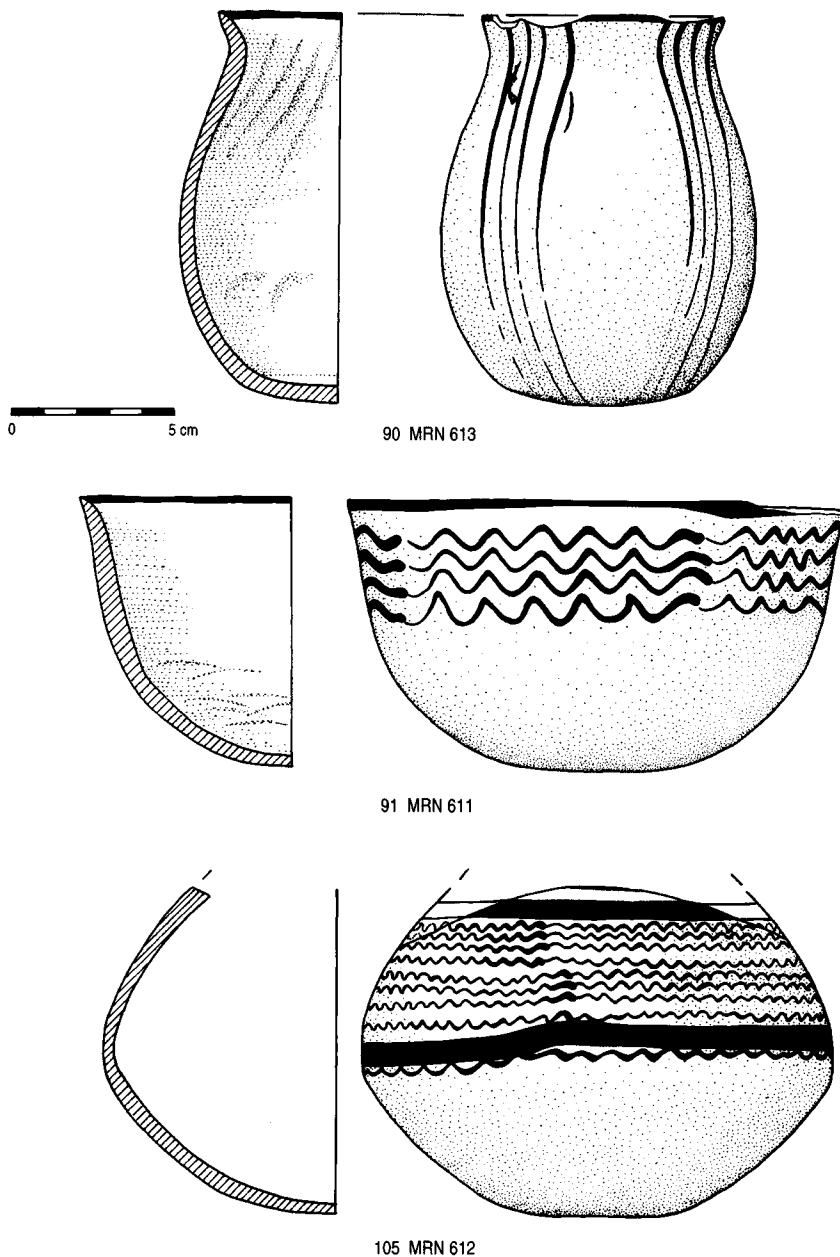

Figure 3. Ubaid Phase E ceramics from burials. Tell Kurdu

Remote sensing utilizing a magnetic field gradiometer covered several large areas of both mounds. Having delineated burnt areas for possible identification of pyrotechnological installations, the results also had a value added aspect in identifying a large, possible tripartite building in the older Northern Mound. In addition to

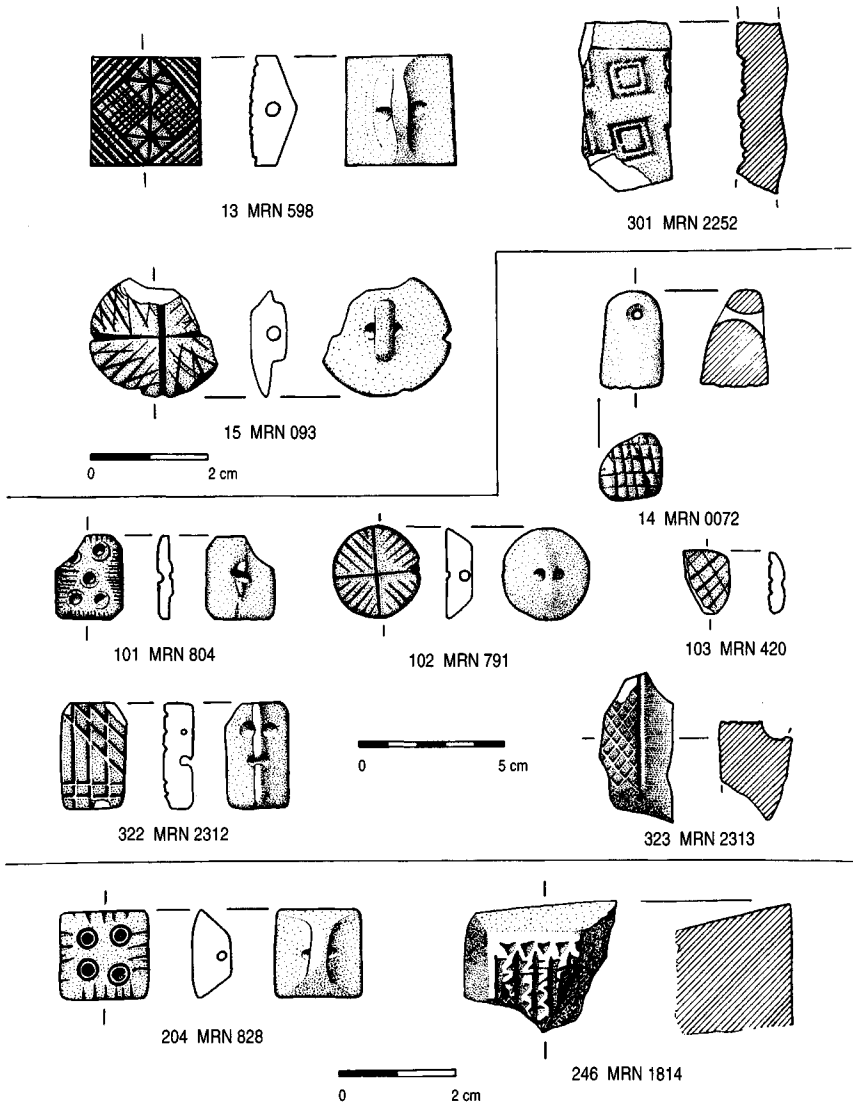

Figure 4. Stamp Seals and Sealings. Tell Kurdu

this feature, previous surface surveys had found vitrified wasters suggesting the location of ceramic kilns. This was corroborated by the magnetometer; two large circular structures appeared as magnetic anomalies.

Quantities of small finds were recovered from the first season, some within and on exterior surfaces of the excavated buildings. These include stone vessels, human and animal figurines, metal, slag and ore, flint and obsidian implements, ground-stone tools, tokens and bailing tags, personal ornaments, and stamp seals. The clay tags and geometric devices found in the Southern Mound architecture offer a clear connection between special function or elite buildings and bureaucratic accounting.

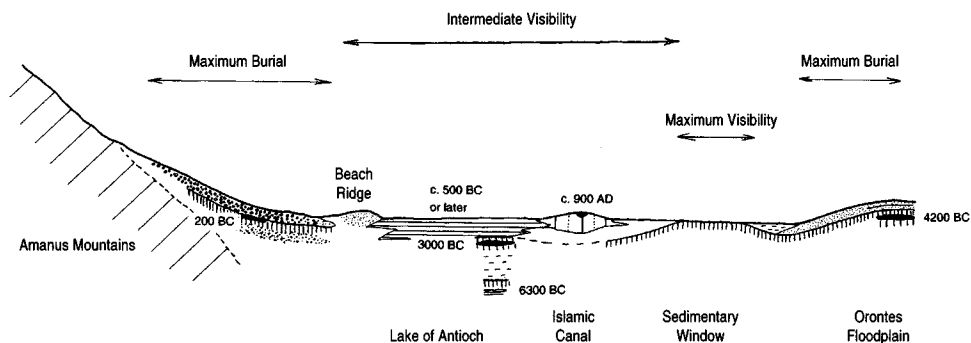

Figure 5. Diagram summarizing the overall sedimentary stratigraphy of the Amuq Basin

This was the first foreshadowing of the subsequent bulk storage of staple products and increased wealth in the form of high status artifacts and their distribution during the Uruk period. A variety of clay lumps were found that might have functioned as sealings on containers, bags, or bales, and could be associated with the control of goods. Perhaps closely related are a number of clay “gaming” pieces, which may be interpreted as tokens or counting devices. As a group, the forms and styles of the seven stamp seals found in excavated contexts resemble assemblages found previously in Phase E at Kurdu, although some examples on the Northern Mound suggest that levels earlier than Phase C may be present.

Animal and human figurines are also associated with the Southern Mound architecture. Ubaid-related stylistic imagery is present especially in the human figurine fragments found in Trench 2 and may reflect ideological aspects of prestige enhancement. Coffee-bean eyes, a conical head (or headdress), and a lizard-shaped face are characteristic of this style. Fifteen sling pellets or missiles were found, constituting a large category of bi-conical and ellipsoid shapes made from a variety of media – clay, serpentine, marble, and other stones.

The excavation recovered several very small pieces of copper, seemingly fragments of tools or ornaments (e.g., awls or pins). In addition, a complete flat ax was a surface find that cannot be dated. Iron ores — hematite and goethite — were used like ground stones to make mace-heads and other dense objects. Chipped stone, including obsidian, and lithics included elongated querns, mullers, and mortars. Polished stone celts and wedges of various sizes, an artifact category that spans Amuq Phases A through F, were common. Bone tools such as awls and needles made from sharpened shafts of animal long bones as well as spatulated tools also appeared. A shaft hole hammer made of antler was also found. Spindle whorls (usually rounded and pierced sherds) and loom weights were abundant.

Field Survey (T. J. Wilkinson)

The 1998 field survey season commenced initially in August 1998 with a small team consisting of Simrit Dhesi, Hatice Pamir, and Jan Verstraete, and then continued under the direction of Tony Wilkinson in early September 1998 when he arrived from Syria. Fieldwork then went on until the end of September with the above team, supplemented by Shinichi Nishiyama. A total of 34 new previously unknown sites



Figure 6. Monumental building on limestone ridge at Kizilkaya (AS 208)

were visited and recorded, which takes the total number of sites recorded (including those published by Robert Braidwood) to 237.

In 1998 progress continued to be made in the reconstruction of the environmental sequence with the discovery of a massive trench through the southwest part of the Orontes flood located near the Byzantine and Ottoman water mill at Sultan Merkezi (site AS 229). This roughly 300 m long cut penetrated down to some 6 m below the level of the floodplain. At its southern end the trench cut through an ancient land surface and alluvial fan that contained later Palaeolithic artifacts. This old land surface must therefore have formed the valley side that accumulated during the later stages of the last (Pleistocene) ice age. After this accumulation a long sequence of sediments was deposited during the last 10,000 years or so as the Orontes River floodplain became built up over the earlier sediments. As a result of this sequence it is now possible to summarize the sedimentation in the Amuq Plain as indicated in figure 5. This composite diagram shows: to the left, the rapid accumulation of gravel fans that dumped some 2–3 m of gravel over the Hellenistic land surface along the Amanus Mountains; in the center is the Amuq Lake, which accumulated after about 500 BC; right of center are levees deposited by Islamic canals; and to the far right are the various accumulation levels of the Orontes floodplain. In other words there seems to have been significant accumulation of sediments over much of the plain, which might therefore have obscured a number of smaller sites. The one area that was not affected by this sedimentation appears to have been the Çakaltepe sedimentary window, an area in the south central part of the plain (right of center in fig. 5) in which the present ground surface approximates to that of the prehistoric period. It was within this window that archaeological sites were best preserved.

The environmental sequence from Lake Gölbaşı (located towards the north end of the plain) continues to be refined by Liz Friedman and Ercan Alp, now with the

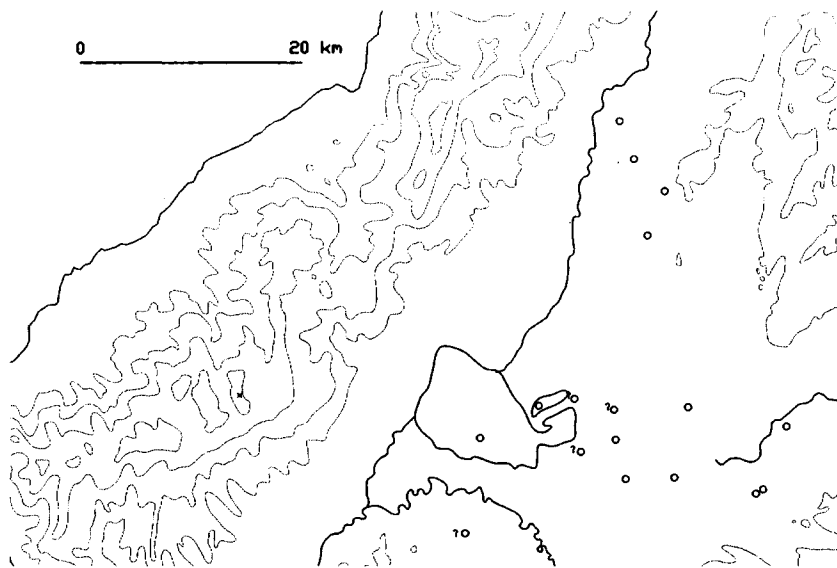

Figure 7. Map showing the distribution of sites of Amuq Phase G (ca. 3000 BC)

additional assistance of Anton Stampfl. As a result of their pioneering work using the advance photon source synchrotron beam at the Argonne National Laboratory to measure trace elements in sedimentary cores, we are now starting to understand the sedimentary sequence from the center of Amuq Lake. From the cores and other sections recorded in the field, it appears that the Amuq Basin might have contained a series of pools or even a small lake around 7000 years ago. This episode would have coincided approximately with the period when Tell Kurdu was occupied and might have provided the requisite valley floor habitat for the numerous large fish recorded as part of the faunal analysis from the 1998 season at Tell Kurdu. The water bodies that existed in the basin center appear to have dried up through the remainder of the Chalcolithic and Bronze Age. After this, the Lake of Antioch became established and the area, as we know from classical records, then became a supplier of fish for the inhabitants of the region.

The advance party of Dhesi, Verstraete, and Pamir had already made important breakthroughs by finding significant new sites on the limestone uplands to the east of the basin. These included a large monumental building situated on top of the limestone ridge of Kizilkaya (site AS 208). This structure (fig. 6), dated to the mid-to late third millennium BC by a scatter of small sherds of red-black burnished ware, consisted of large mainly limestone blocks that formed an elongate trapezoidal structure measuring 16.4 m across the short end. Although its overall length was some 63 m, the main structure appears to have been somewhat shorter. From its location and monumental structure, this site seems to have functioned as a major fortified building that overlooked the main north-south route which followed the eastern side of the plain. In addition to this small but important site, the team found a massive dolmen field consisting of some 144 stone tumuli that presumably represent

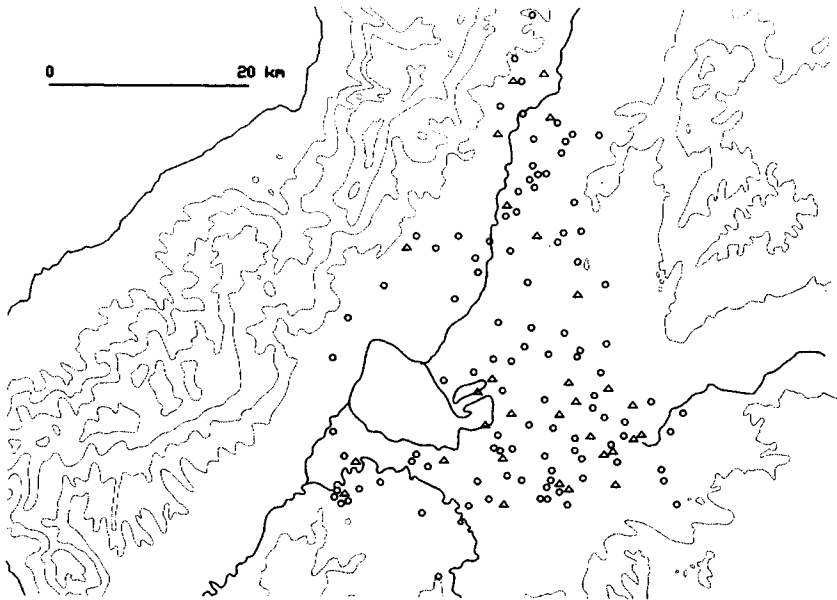

Figure 8. Distribution of Roman and Late Roman sites

prehistoric tombs. These are currently being studied by team member Bakiye Yükmén of Mustafa Kemal University.

On the plain itself one of the more significant sites is the large low mound of Karacanlık (AS 92) that covers some 8–10 ha (20–25 acres) and was occupied through the late fourth and early third millennium BC (that is during Amuq Phase G). When originally visited by Braidwood in the 1930s this site was surrounded by marsh, but we now know that this marsh development only occurred in the last 2,000 to 3,000 years. At the time of occupation, however, this small town was apparently surrounded by dry cultivable soils that eventually became inundated by the rising levels of the marsh during the Late Roman, Byzantine, or early Islamic periods. This pattern of inundation is therefore very similar to what happened to the small site of AS 181 which became flooded by the rising waters of the lake (see *1996/97 Annual Report*). Altogether fifteen occupations with Amuq Phase G were recorded, with three additional occupations of probable or possible Amuq Phase G date (fig. 7). This is a significant increase over the six sites recorded by the original survey.

In the earlier seasons most of the survey was undertaken using the standard Near Eastern technique of mound survey, but to increase the total recovery of sites we have employed more intensive survey techniques that entail off-site walking transects across the plain between sites. Although productive in terms of site recovery, this method was not without tedium, the procedure being for the team to be spaced at intervals of roughly 20 m apart and walking along parallel alignments, collecting pottery across a field until the opposite side was reached. This methodology, which was conducted over approximately 110 ha of the Amuq (ca. 272 acres), confirmed that during the Roman and Late Roman periods the plain was very well

ARCHAEOLOGY

populated. Settlements were scattered over the surrounding foothills to the southwest, especially near Antioch, where they seem to have included small dispersed settlements, rural buildings, and small farmsteads (fig. 8). The sites in the southwest corner are very close to ancient Antioch, and on the basis of the presence of masonry remains, roof tiles, and lumps of mosaic tesserae, many can be interpreted as the remains of Roman villas such as have been described by the ancient writer Libanius (e.g., sites AS 226, 228, 235, 236, 237).

It is also possible that a number of the late Roman sites were settled by people who were displaced by the expanding lake because the geoarchaeological surveys clearly indicate how the late phases of the lake had overlapped onto field soils that had been cultivated in the Roman and Late Roman periods. This was particularly clear to the north of the lake near site AS 87. Also for the Roman period we recorded briefly the destruction wrought by the expansion of the modern city of Antakya and its suburbs. Among the numerous discoveries of heavily bulldozed Roman, Late Roman, and Byzantine suburbs was a small conduit, presumably constructed to supply water to the eastern part of the city.

By the end of the 1998 field season we had resurveyed most of the Amuq Plain, artifacts had been collected from most sites, and geoarchaeological sections had been recorded whenever possible. In addition, some progress has been made towards an understanding of settlement in the surrounding hills. Nevertheless much remains to be done. Pottery collections from the sites need to be studied, drawn, and analyzed; sites that were occupied at the same time as Tell Kurdu need to be revisited and collected in more detail, and finally we still need to survey in more detail the adjacent drier uplands as well as the Orontes Valley to the southwest, and the Kara Su Valley to the north. This we hope will be undertaken in future seasons.

The Amuq represents an area where potential multi-project initiatives can be undertaken and students, faculty, and colleagues of the Oriental Institute will be able to investigate a variety of sites.

TELL BEYDAR SURVEY

Tony J. Wilkinson

The 1998 field season at Tell Beydar was short, only some two weeks, and took place during the second half of August. In order to avoid overcrowding of the dighouse it was necessary for us to undertake our fieldwork before the main European/Syrian team arrived at the end of August. Unfortunately this meant that fieldwork had to be conducted in virtually the hottest part of what had been a very hot year; nevertheless we sweated it out and our fortitude was rewarded by results that significantly extended those from the previous year. It was our objective to complete the basic survey of the 12 km radius survey area around Tell Beydar. As in



Figure 1. Sampling the Bronze Age tell of Seqar Foqani. Small white specks near summit are team

1997 our team was drawn from the University of Ghent (Patrice van Dorpe), the University of California at Berkeley (Eleanor Barbanes), and the University of Chicago (Tony Wilkinson and Jason Ur). In addition, students from the University of Damascus provided help both in the field and with the pottery analysis. As before we are grateful to the directors of Tell Beydar excavations, Marc Lebeau and Antoine Suleiman, and the director of the University of Leuven mission Karel van Lerberghe, for providing help in the field. Funding was provided by the Belgian Mission, the Oriental Institute, and the British School of Archaeology in Iraq. Moreover, the work would not have been possible without the considerable support of Professor Dr. Sultan Muhesen, director general of Antiquities in Damascus.

By the end of the second season we had recorded a total of eighty-two sites from an area that covered some 450 sq km (174 sq miles); this amounts to one site every 5.5 sq km (one site every 2 sq miles). However, this figure of eighty two sites rather obscures the fact that much of our time was spent collecting and sketch mapping the lower towns of sites that had already been discovered in previous seasons (and which therefore could not be logged as newly discovered sites). Fieldwork by the regional team demonstrated that most of the small sites in the area were either pre-Bronze Age or post-Bronze Age in date. That is they were not Bronze Age, and more specifically most tells had major occupations in the Early Bronze Age. This supports our conclusions from the previous year that for the third millennium BC, the dominant form of settlement was the large fortified tell. The surface collection scheme undertaken by Ur, van Dorpe, and their Syrian co-workers further refined our information base on these large, high mounds (fig. 1).

By the second millennium BC, however, when large parts of the area had been abandoned, it became obvious that settlements had started to grow up as lower towns around the bases of tells. This shift was not simply a matter of the inhabitants

ARCHAEOLOGY

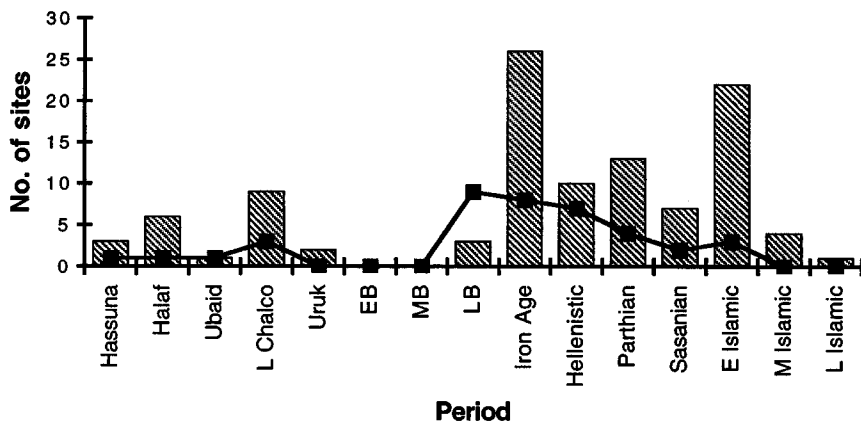

Figure 2. Number of lower towns below tells (■) versus number of small sites per period. Tell Beydar Survey 1997/98

of the tells moving their houses and possessions downslope. Instead the evidence suggests, as has been noted for parts of the eastern Khabur, that there was a significant period during which many of the mounds were deserted. Subsequently, after a gap of several centuries, lower towns then grew up at the foot of many tells in the mid to late second millennium BC. There appears therefore to have been a period in which the local tell-dwellers either moved out of the area or became nomadic. They, or other communities, then returned during the Mitannian or Middle Assyrian period to re-establish small villages at the feet of pre-existing mounds.

This development of lower towns therefore proved to be the precursor of the development of the distinctive pattern of dispersed Iron Age rural settlements that occurred in the first millennium BC (fig. 2). This pattern, the analysis of which formed part of the Berkeley Ph.D. dissertation of Eleanor Barbanes, is characteristic of a more widespread pattern that occurs throughout much of northern Syria and Iraq during the earlier first millennium BC. As noted in the *1997/98 Annual Report*, when the area came under the administration of the Neo-Assyrian Empire, it became possible for small outlying communities to grow up in the countryside (fig. 3). This was presumably in part because of the protection afforded by the empire. Although the development of such villages and farmsteads must partly result from the settlement policies of that administration (which included the forcible transfer of people from other parts of the empire), it is also likely that a significant number of settlements might have been spontaneously settled by Aramaean nomads.

An additional archaeological problem concerned the morphology of the main Tell Beydar. Today the main central mound is conspicuously surrounded by an outer circular wall broken by gaps of what appear to have been gates. Between the main tell and the outer wall lies a broad flat area the surface of which was at approximately the level of the local stream, the Wadi Awaidj. This broad circular depression had attracted much speculation from the team members and visitors: was it a flat lower town area, the buildings of which had been covered by soil washed from the site or flooded by the wadi, could it have functioned as a cattle or sheep corral, or was it simply a defensive moat? The last few days of the season were therefore

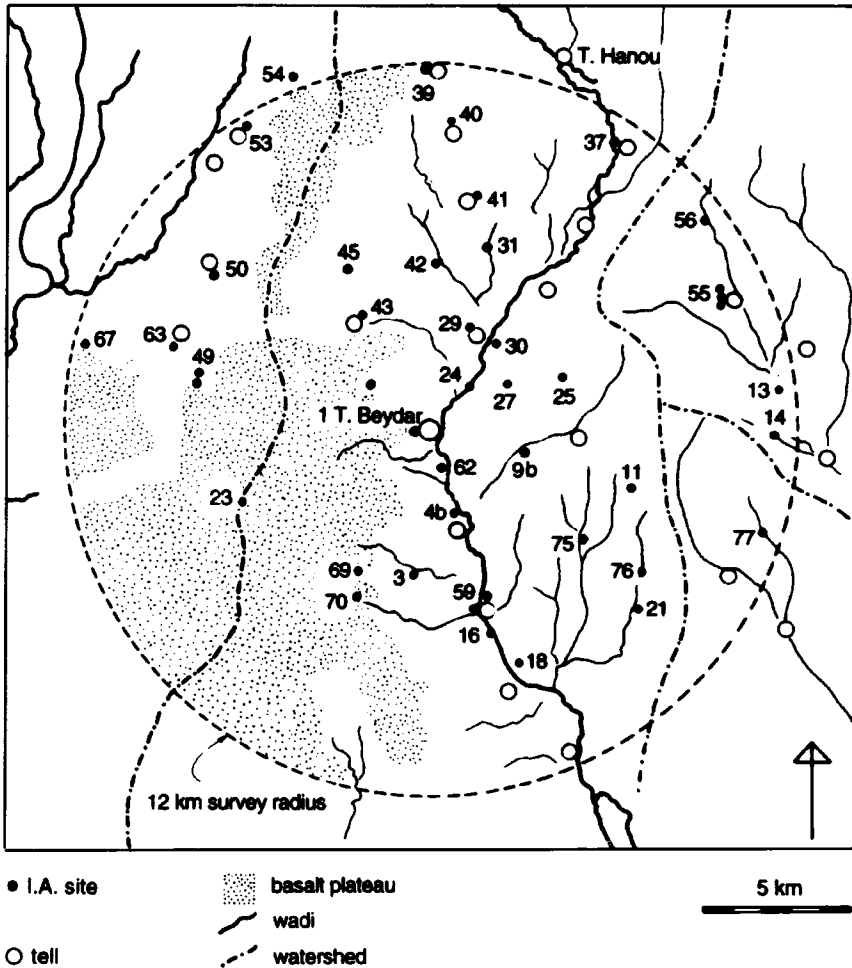

Figure 3. Tell Beydar survey. Distribution of Iron Age sites (●) versus main tells (by Eleanor Barbanes)

devoted to testing these hypotheses by using a backhoe to excavate sample trenches partway across the depression (fig. 4). Although lacking subtlety, this equipment proved effective, especially because the area trenched was virtually devoid of cultural remains. Overall we managed to dig three major trenches across the depression around the main tell. The first, to the south, clipped through the wash deposits at the base of the tell and reached the buried soil upon which the site was built. This soil had evidently been cut away on the north side of the tell in antiquity, and then itself became covered by meters of sediment washed from the tell. This southern trench, up to 6.5 m in depth, had pottery to 5.5 m. The second trench was through the center of the depression and extended to a depth of 4 m below the level of the ground surface. Pottery was recorded in the fill to a depth of around 3.7 m. The third trench through the northern part of the depression also cut through in-washed deposits, but these had washed down from the outer wall of the site. This trench penetrated to



Figure 4. Backhoe in action digging north trench. Tell Beydar step trench is in background

about 4.2 m depth and cut through an Early Dynastic burial towards its northern end. We are glad to report that the pottery was intact (fig. 5). In general, pot sherds in this trench were contained in the fill to depth of about 3.4 m. As with the south trench, we were able to recognize a point at which the old ground surface had apparently been cut away. Therefore, in all three trenches the pottery was found in the fills to virtually the base of the trench, and it was possible to recognize the old land



Figure 5. Late Early Dynastic burial group cut into buried ground surface alongside north trench

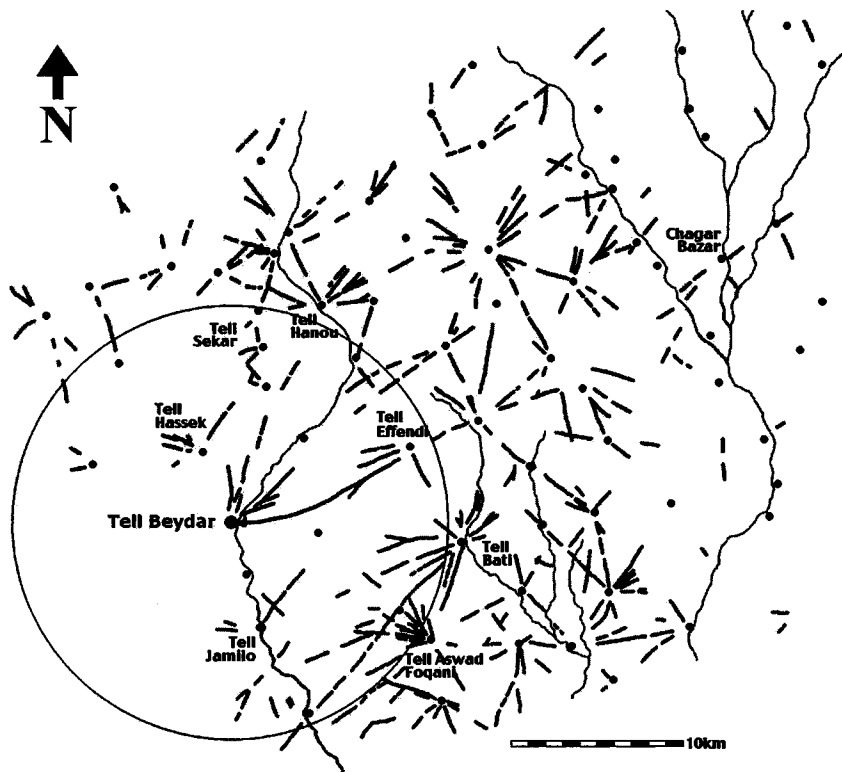

Figure 6. Linear hollows in area of Tell Beydar (by Jason Ur from CORONA images). 12 km radius survey area is encircled

surface that had been cut to both the north and the south. The pottery contained in the fills was always in the form of small fragments and resembled, as far as we could tell, the pottery of the Early Dynastic/Akkadian occupation of the main site itself. We therefore can suggest that during the early Bronze Age the main tell of Beydar was surrounded by a large excavated depression or moat that was at least 4 m deep, and which had been cut into the natural ground surface of the floodplain of the Wadi Awaidj. Although little could be said about the precise mode of deposition of the silt/clay deposit that filled the ditch, the level of the ground surface of the depression is approximately at the level of the floodplain, and it seems logical that it would have flooded periodically, although no classic alluvial or waterlogged deposits were evident in the sediments record.

Progress was also made with the mapping of linear hollows in the area of Beydar. Although a preliminary map was produced in 1997 (see *1997/98 Annual Report*, p. 22, fig. 4), this was made simply by taking a photographic slide of the original photographic strip, projecting it against the office wall and then drawing off on tracing film the faint traces of the shallow linear hollow features that radiated away from the sites. In 1998, by contrast, the main photographic strips were scanned at a high resolution so that they could then be viewed and mapped using Adobe Photoshop software. The preliminary result of this mapping, by graduate student Ja-

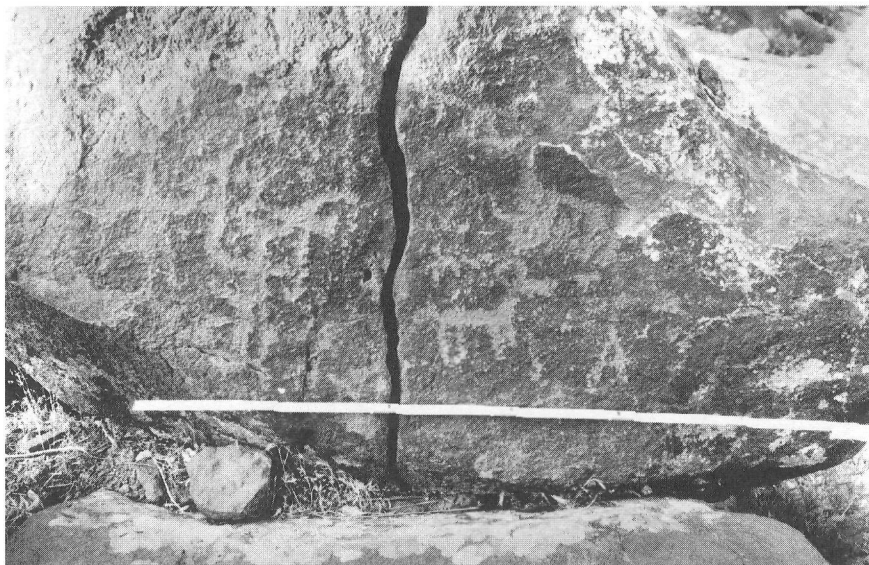

Figure 7. Ancient but undated rock art pecked into basalt rock on plateau edge southwest of Tell Beydar

son Ur, is shown in figure 6, which shows a web of linear hollows that both radiate from the main tells in the area (e.g., the group around Tell Bati to the east of Beydar) and also run from tell to tell across the land surface. A good example of the latter is that running from Beydar to Tell Effendi and then on to the large site of Chagar Bazar. The last named site was originally dug by Max Mallowan from 1935 to 1937 and currently is being re-excavated by a joint English-Belgian-Syrian mission directed in part by Augusta McMahon (Ph.D., University of Chicago). These hollows appear to be the result of the sustained movement of people and their flocks across the ground surface to reach their fields, outlying pastures, or nearby settlements. As a result of such movement over thousands of years the ground surface appears to have become worn down and hollowed, both by the action of the feet, and by concentrated water flow that inevitably drains along them. Many of the hollows radiate from Bronze Age sites, and therefore appear to be of this date, but others, as suggested in the pioneering study by van Liere and Lauffray, may be somewhat later. In general these features appear to provide a palimpsest of many of the original route systems that crossed the area.

A major problem for archaeological survey in the Near East has been the recognition of pastoral nomadic sites. Because nomads rarely stay in the same place for long periods, have few material possessions, and live in flimsy structures, their traces are ephemeral. Nevertheless, as a result of the 1998 season, potential settlements of pastoral nomads have now been recognized in many places, particularly around the edges of the basalt plateau that lay to the west of Tell Beydar. Such sites tend to be low, unrounded sites, often with only a few stone circles or roughly rectangular structures. Artifacts, although present, are scarce and often belong to a wide range of periods. Such sites seemingly first appeared in the Iron Age, but there is more evidence for them in the Parthian, Sasanian, and Islamic periods. Although

many of the apparent pastoral sites are on or around the plateau, not all sites on the plateau are the remains of pastoral nomadic camps. It is therefore now possible to summarize activities on the plateau as: pastoral sites, outcrops with rock art (fig. 7), quarry areas for basalt stone, temporary living areas associated with specialized activities such as quarrying, and rare sedentary settlements. Interestingly, we have yet to record any evidence of Bronze Age or pre-Bronze Age activity on the basalt plateau.

BIR UMM FAWAKHIR

Carol Meyer

After four seasons of survey work, the 1999 season was the Bir Umm Fawakhir Project's first opportunity to excavate. The site, a fifth–sixth century Byzantine/Coptic gold-mining town in the central Eastern Desert of Egypt, has now been mapped in detail, fourteen outliers of the same date have been documented, and special studies of the local geology, ancient mines and mining and ore reduction techniques, pottery, population size, and historical background have been undertaken, but there were questions about the site and its inhabitants that only excavation could address. The assumption was that the site was basically one period, but was it inhabited more or less continuously for 150 years or so, or were the mines worked for a while, abandoned, and then reopened like the Roman granite quarries at Mons Claudianus? All evidence so far points to the workmen being Egyptians and not Nubians as has been suggested, and career miners, not slaves or prisoners as is often assumed. But could the contents of the houses and their adjacent trash heaps shed further light on the inhabitants and their families?

The team was in the field from 5 February through 5 March and excavated two houses, two trash heaps, one outbuilding, and erected a barricade at the entrance to the main settlement. The team consisted of Carol Meyer as field director, Clare Leader, archaeologist; Henry Cowherd, photographer; Mohamed Badr el-Din Omar, geologist; Richard Jaeschke, conservator; and Thomas Roby, architectural conservator. Job titles, however, became more than a little flexible, and no six people could have accomplished more in so little time. We were assisted by Seif Shard Mahmud, our fine rais, and nine Qufti workmen; Girges Samwel of El Mohandes for Construction; Abd el-Jalil Mohamed Samir, driver; and Wail Karam and Ayman Hindawa, inspectors.

Building 93 (figs. 1–2) in the middle of the main settlement was selected as being an utterly ordinary five-room house, well preserved, unlooted, and flanked by two promising trash heaps. Excavations within the house, under the supervision of Clare Leader, began with a back room, B, at the foot of the cliff. A friable amphora body was set into the floor, perhaps as a drain, perhaps as a fireplace, though ash

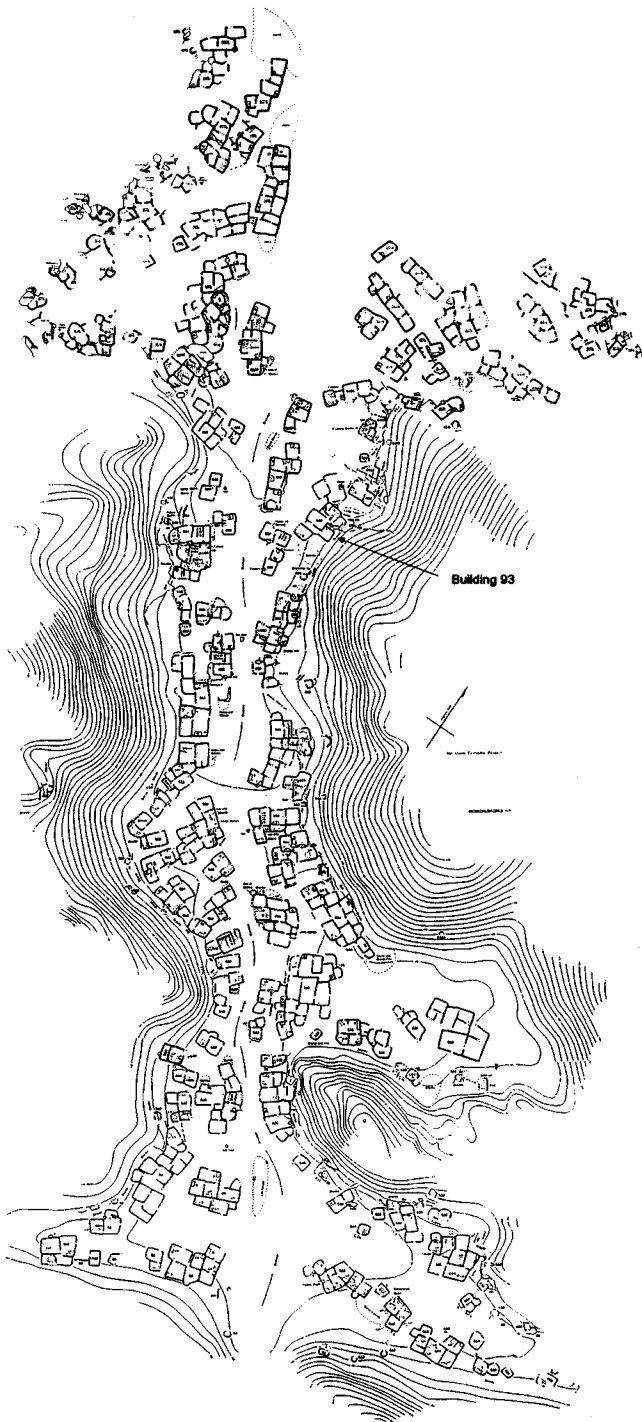

Figure 1. Bir Umm Fawakhir areas mapped in 1992, 1993, and 1996, showing location of Building 93

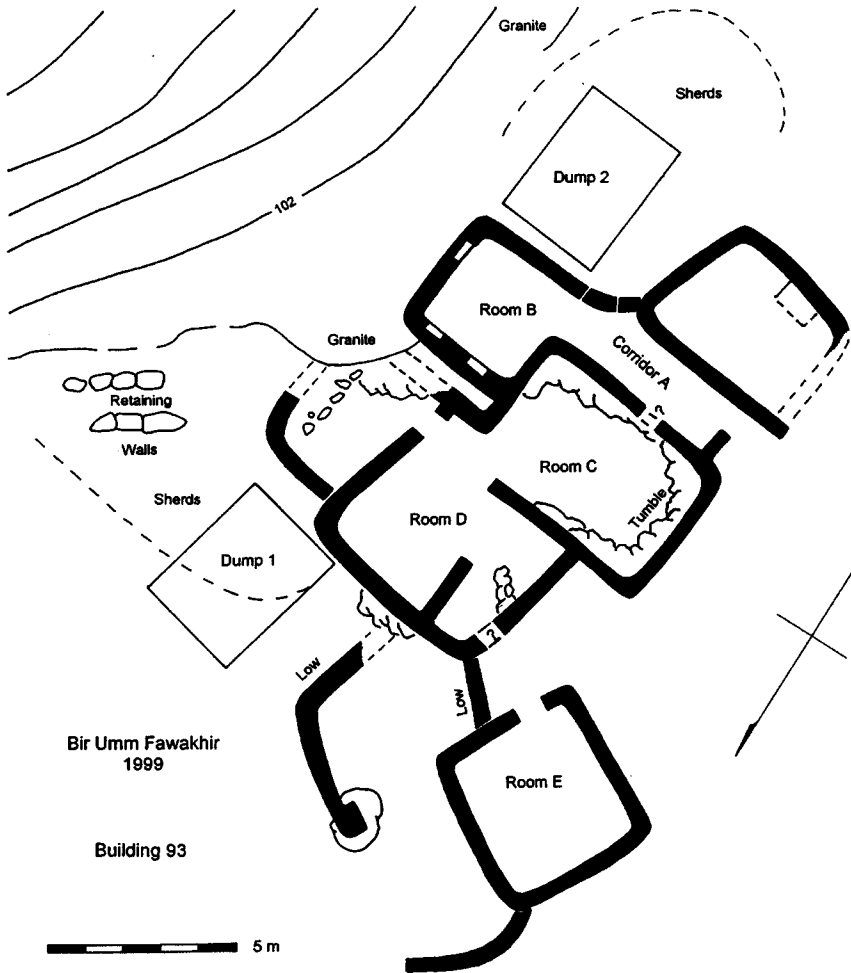

Figure 2. Plan of Building 93 and Dumps 1 and 2 before excavation

was not abundant. Close by lay an iron ladle upside down (fig. 3). Corridor A had one easily distinguishable floor level rich in matted, brownish, organic material. The fill below contained numerous animal bones, some articulated, but the surprise was half a copper-gold alloy bracelet. Room C was only partly cleared for fear that removing too much of the rock tumble would cause some of the dry stone masonry walls to collapse. Still, the northern half revealed a bin sided and floored with granite slabs, but filled with a fine silt that gives no immediate clues as to its original contents. Nearby, resting upside down on the floor was an intact pot (fig. 4). Lifted with a certain amount of fanfare, it had nothing underneath but some whitish powder, which was collected for analysis. Building 93 yielded a surprising array of other finds: an iron wedge, a Bes amulet (fig. 5a) — this in a supposedly Christianized town — beads, an agate ring bezel or gem, two tiny coins, and six emeralds. All the emeralds are unworked crystals, and they probably came from the emerald mines at



Figure 3. Building 93, Room B. Granite bedrock to right, amphora segment and iron ladle in angle of meter sticks, threshold stones in lower right corner

Gebel Sikait near Berenice (modern Mersa Alam) far to the south. What they are doing at Bir Umm Fawakhir is unknown, but they do seem to have been collected as items of value, and their presence here does not suggest absolute imperial control over the emerald mines. Room D was only sampled the last few days of the project, but the southwest corner revealed a deep, stone-lined feature. It is too small and badly located for a well and it is not lined for water retention, so it may be a carefully constructed drain. Room E was similarly tested on the last three days. It proved to be filled with 40 cm of fine, windblown silts over a layer of stone tumble that may mark the beginning of occupational debris. Still, it does indicate that buildings near the wadi bottom and the main street probably are not so badly ruined as they appear, just deeply sanded up.

A 3×4 m trench in the trash heap on the north side of Building 93 was expected to be about half a meter deep and full of organic debris pertaining to Building 93, and perhaps ostraca. Organic debris was in abundance, and also potsherds, but we almost immediately encountered layers of fine gray ash as much as 40 cm deep. These proved to be fill around four ovens or tabuns (fig. 6). The largest, tabun 1, has a ceramic liner surrounded by packed ash and a stone rim about knee high. The ceramic liner of tabun 2 had collapsed into the inside of the oven, but the pieces permitted us to see that it had been constructed of broad slabs of clay set edge to edge and smoothed down. The oven was also full of dung, and an experiment with modern dung produced the same kind of fine gray ash as that packed around the tabuns. This answers one question about the ancient site, namely what the inhabitants were using for fuel in the desert. The third tabun had no lining, only a rim of stones, and the fourth consisted of a ceramic rim ruined to the floor level of the other three.

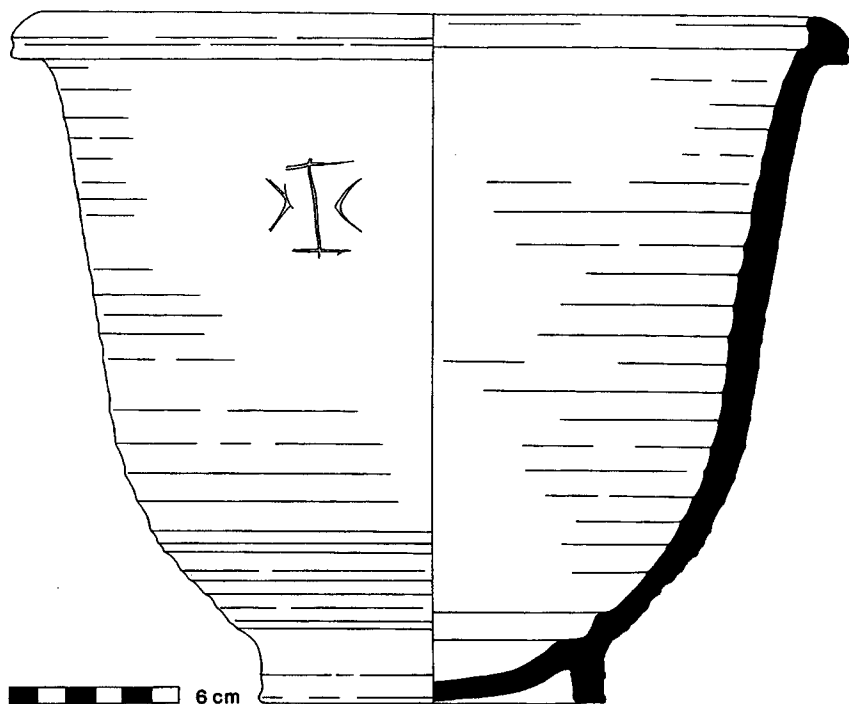

Figure 4. Vessel from Building 93, Room C

We wanted to leave the tabuns intact but also to reach bedrock, so we laid out a smaller 180×150 cm trench in the northwest corner. This revealed some large stones set at an angle with evidence of burning in the corner. Fill below that level was a fine, sandy silt that preserved two intact pots resting on a floor of packed silt (fig. 7). The taller of the two had five holes deliberately punched in the bottom. Our best estimate at the moment is that it was used for making the soft white cheese still popular in local villages. The other pot was large, rounded, and wide-mouthed, perhaps for milk. Cheese-making is in any case a good solution to the problem of keeping milk in the desert. Probably unrelated, the complete skeleton of a rodent larger than a mouse was recovered at the north balk.

At this point we were 1.40 m down without sign of bedrock, and it was becoming difficult to work in the small trench. Therefore we laid out a second 3×4 m trench on the sherd dump to the south of Building 93. Again, it yielded masses of sherds and organic material: bones, sometimes with hide still attached, teeth, charcoal, dung, wood, twigs, bark, olive and date pits, shell, bits of fabric and yarn, twine, and scarab beetles. Once again, the debris proved to cover a kitchen area, this time with three tabuns (fig. 8). The largest was ceramic lined and partly rimmed with stones. Instead of ash fill, however, it contained a mixture of organic materials, including the largest pieces of fabric recovered. The middle tabun looked like a pot smash at first, but turned out to be the top of an amphora, rim, neck, handles, shoulder, and painted dipinto, set upside down and used as a miniature stove or oven. The third tabun consisted of the middle section of a ribbed amphora set in a rim of

ARCHAEOLOGY

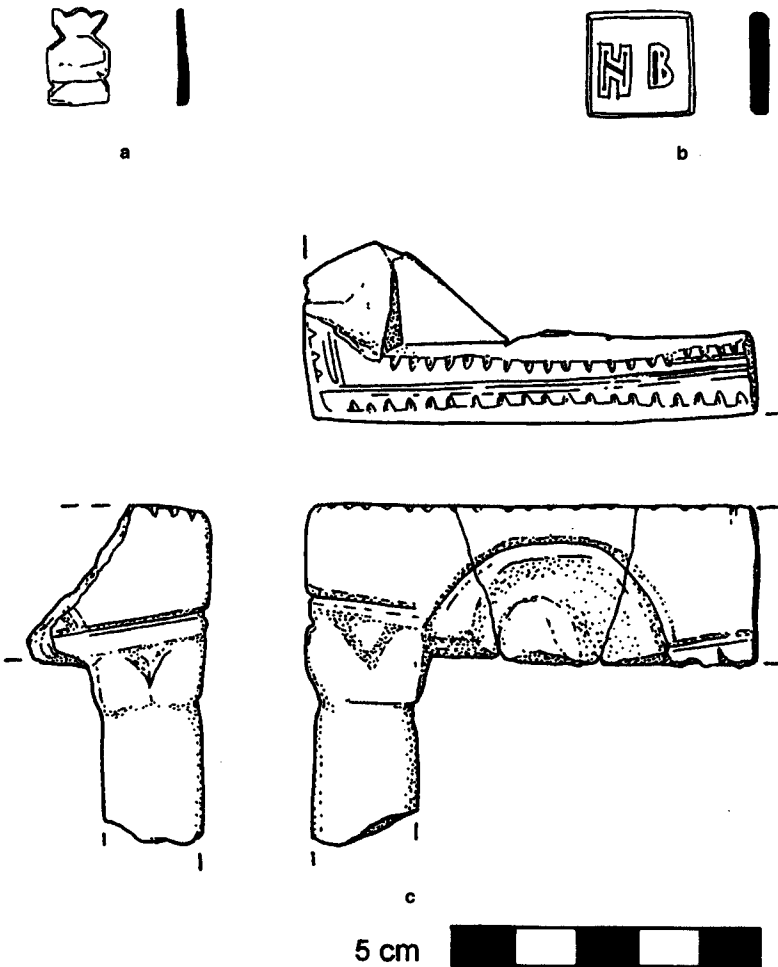
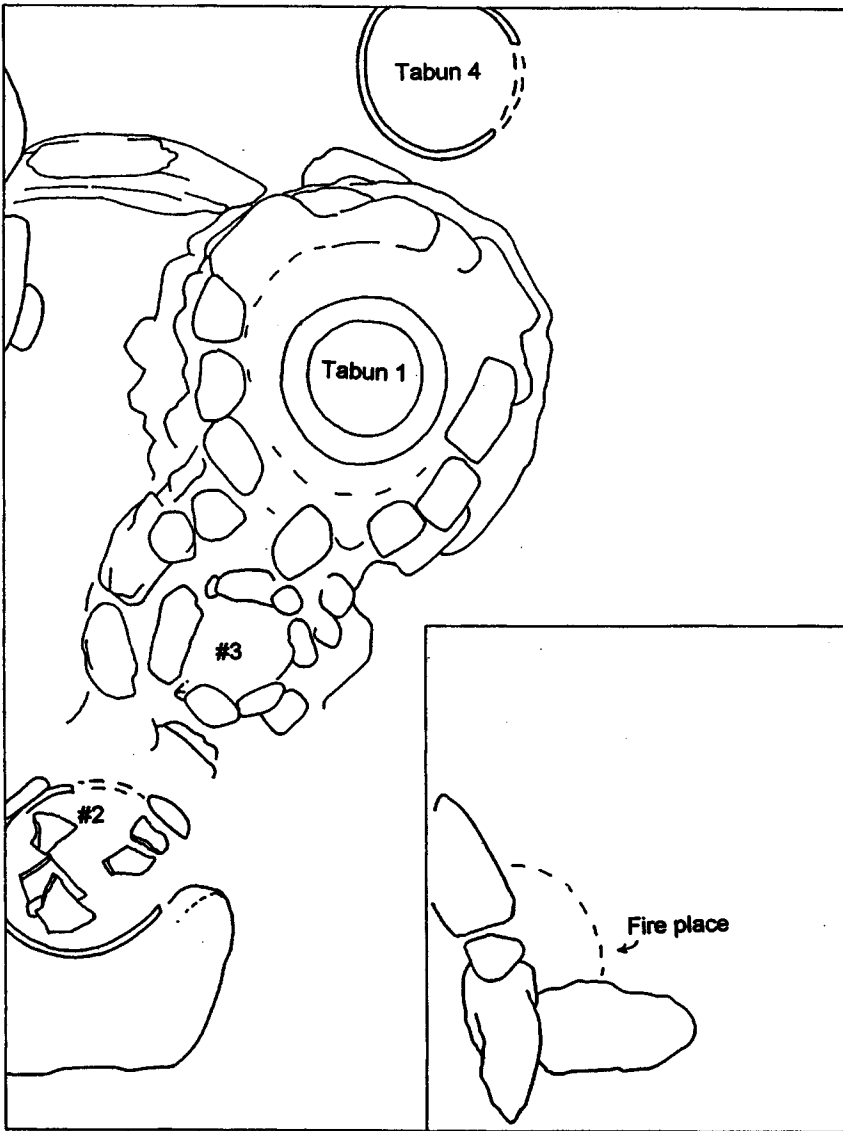

Figure 5. (a) Copper-bronze Bes amulet, (b) copper-bronze weight, and (c) incense burner-like artifact

stones. The ground here slopes steeply down from the cliff on the eastern side, so neither bedrock nor a good floor was reached on the western side; it would have been necessary to extend the trench. However, it does seem that the dump 2 installation, approached from the west, would have looked like a low kitchen range at least knee high. The two kitchen areas partly answer another question about the settlement. In addition to the two- and three-room houses and the larger agglomerated units, a large number of one-room outbuildings are scattered around the site. Their function is unknown, whether storerooms, workshops, animal shelters, latrines, or other, but it now seems that they would not normally have been needed for kitchens.

The second house excavated, Building 177 (figs. 9–10), was selected as perhaps being a little different from the others at the site. From north to south there is no obvious differentiation between the houses, construction techniques, or the debris around them. Building 177, however, is situated high on a granite knob called



Bir Umm Fawakhir 1999 Dump 1

1 m

Figure 6. Plan of Dump 1, four tabuns (upper floor) and fire place (middle level)

the Hillock overlooking much of the site, and more fancy stamped plates and dipinti (painted wine jar dockets) were recovered on and around the Hillock than elsewhere. Building 177, however, proved to have a much simpler occupation history than Building 93. In most cases bedrock was only a few centimeters below surface. The exception was Room A, which had a clearly marked floor level of brownish or-



Figure 7. Dump 1, fireplace stones in lower right, two intact jars on lowest floor

ganic matter, and where bedrock dipped steeply, much fill below. The only internal installation was a small fireplace made of thin granite slabs and partly filled with burnt twigs, branches, and charcoal, but no dung. Small finds include more beads, four tiny coins, five more emeralds, all three pendants recovered, a small copper-bronze weight (fig. 5b), and pieces of two incense burner-like artifacts. The latter are rectangular with a shallow depression on top and carved from very soft stone (fig. 5c). The fancier of the two has legs in the shape of columns and arches carved on the side. Two similar items were recovered in 1997, and none of them have any sign of burning. They may be church related, but exactly what they are is still unclear.

Clare Leader also excavated Building 181 on the Hillock. It is a one-room out-building, consisting primarily of large granite boulders closed off in the back to make a small room. It had a sandy floor and yielded some beads and glass sherds but few other finds, not even pottery, though it does not seem to have been a latrine.

Conservation is always a concern for archaeological sites, so with the support of the Egyptian Antiquities Project we constructed a boulder barricade at the entrance to the site to keep vehicles from driving up the ancient main street and possibly damaging the dry stone masonry walls of the houses. Large boulders matching those on-site were moved from three locations along the Quft-Quseir road and spaced at the entrance to the site in a double line in order to permit water from flash floods to rush out and visitors to walk in, but no cars. The work was undertaken by El Mohandes for Construction from Luxor, under the supervision of Girges Samwel, engineer, and Thomas Roby, conservator.

In addition to the finds mentioned above, the project recovered 73 dipinti, both the large and small types of inscriptions, though as usual most are fragmentary,



Figure 8. Dump 2. Three tabuns (sherds have been removed from middle one)

faded, and hard to read. One small inscription painted under an amphora handle reads “tetra,” but we do not know to what the “four” pertains (fig. 11a). Sixteen sherds with stamped designs were also found. The motifs are generally Christian: crosses, Chi-Rho, palm branches, and one that may be a dove, but looks more like a duck (fig. 11b). Ray Johnson of Chicago House said that it reminded him of nothing so much as the “Sa Re^c” hieroglyphs, or “Son of Re^c,” the ancient title of kings.

Have we answered the questions we asked initially? Room C of Building 93 has at least two floors, and the dump 1 kitchen installation has at least three occupation levels. The lowest levels reached, the one with the upside-down pot in Room C and the “cheese factory,” were thick layers of fine, sandy silt, presumably wind-blown. This suggests a hiatus in the use of this area at least, as if the settlement and mines were used for a while, abandoned, and then reopened. We still cannot say whether all or almost all the buildings in the main settlement were inhabited simultaneously or not; only two have been sampled and as far as surface finds go, there is little to distinguish one part of the site from another. Whoever lived in Building 93, at least in the latest stage, however, was not poverty stricken, judging from the copper-gold bracelet, gem stone, coins, emeralds, and other finds. The large amount of bone from sheep, goats, and larger animals, the olive and date pits, the presumed cheese-making installation, and the large number of wine amphorae do not suggest a particularly impoverished diet either. None of this supports the old idea of miners as slaves or prisoners. Rather, the data are much more in line with the new evidence about the quarrymen at the Roman site of Mons Claudianus to the north, who were paid some 26 drachmas per month plus a grain ration and at times a wine ration. Work there, however, depended on imperial commissions such as the Pantheon that required special granite columns. Between commissions the site might have been

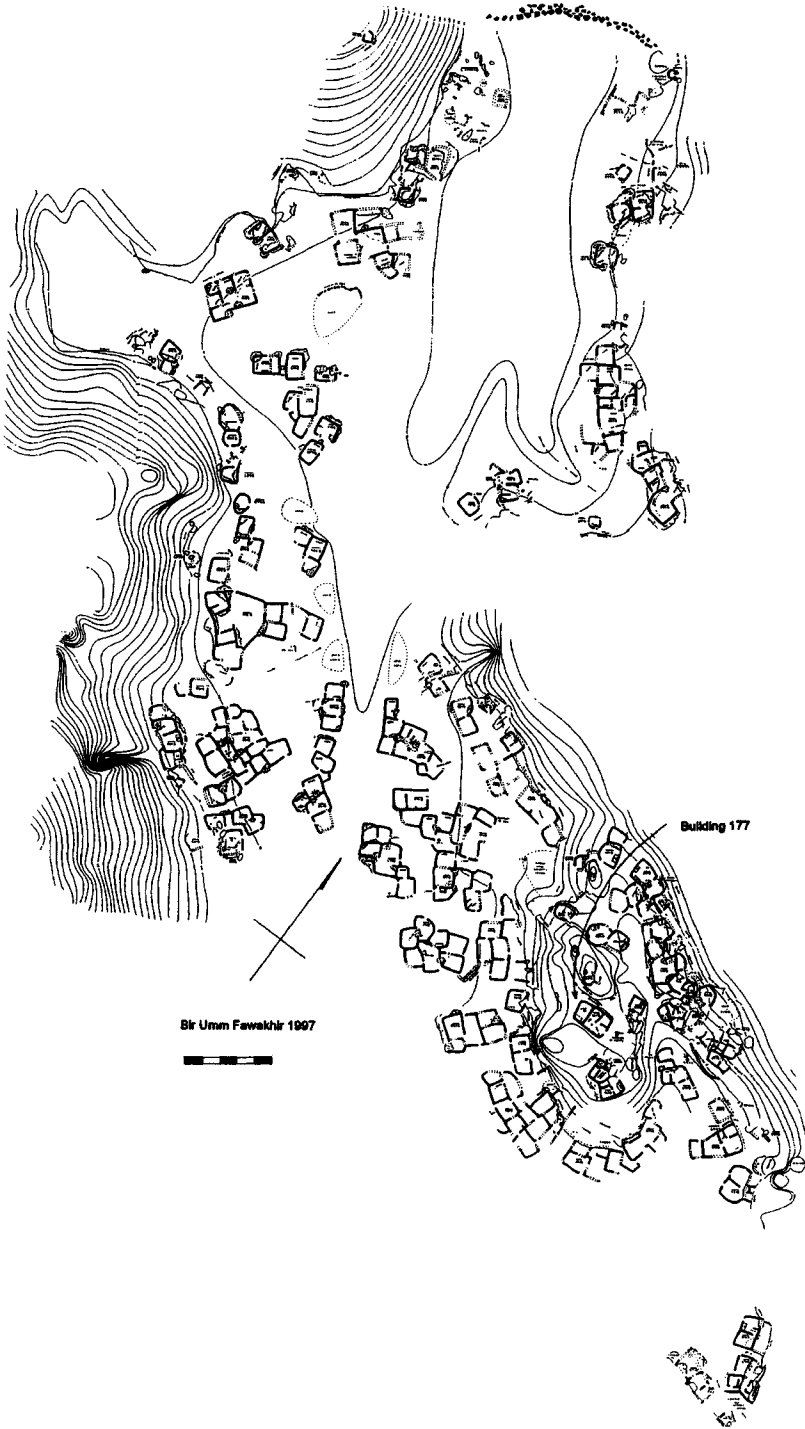

Figure 9. Bir Umm Fawakhir area mapped in 1997, showing location of Building 177

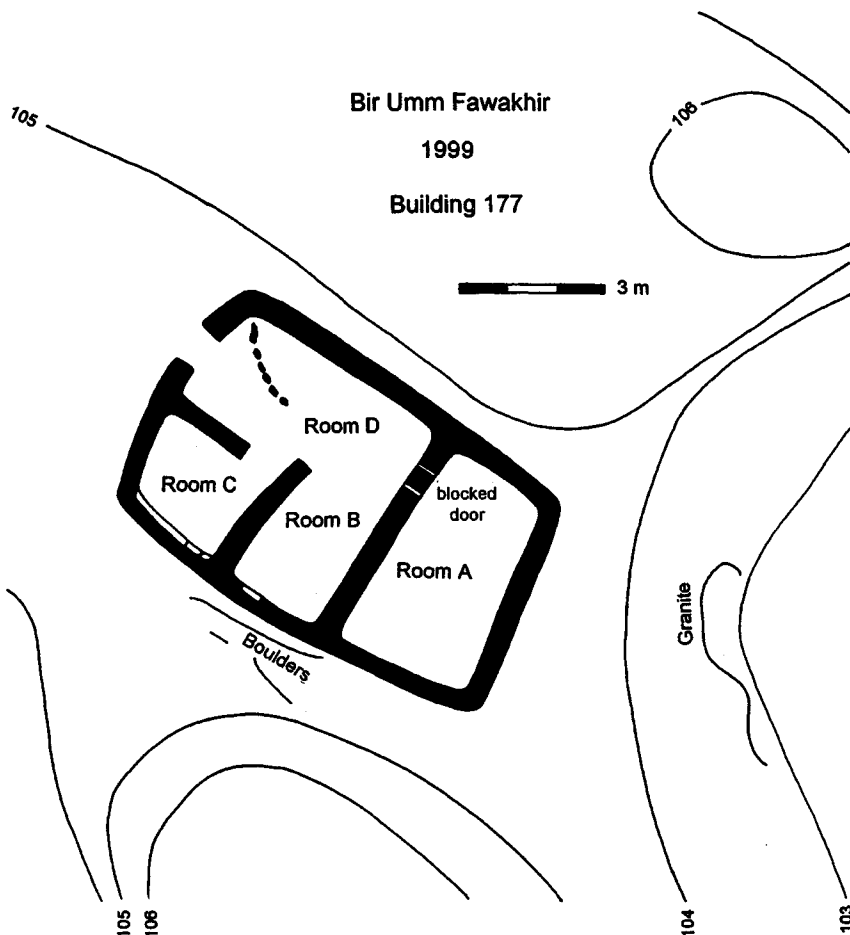

Figure 10. Plan of Building 177 before excavation

abandoned for a generation or so. Work at Bir Umm Fawakhir similarly must have depended on the imperial need for gold, which was urgent, and the willingness to expend grain and other resources to get it. Since this is hard rock mining of a difficult ore, sulfides in quartz veins in Precambrian granite, the mining would have required a very large work force, far beyond the reach of the individual miner seeking to pan out alluvial gold. It is hard to see who, at this period, apart from the government, could have financed, organized, and supplied the workers at Bir Umm Fawakhir. Pots are not people, but in this case we have about six Nubian handmade sherds to bucket after bucket of Nile silts, marls, Aswan pinks, and amphorae, and there is nothing else so far to suggest that the workers were not Egyptians. By the fifth century they should be Christian or at least Christianized, but the Bes amulet and the duck-stamped plate suggest that something of the old beliefs survived or the new beliefs were being interpreted in light of the old. A similar pattern at Berenice

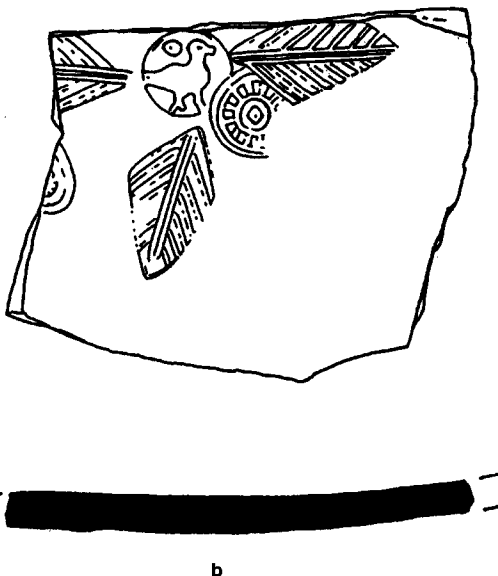
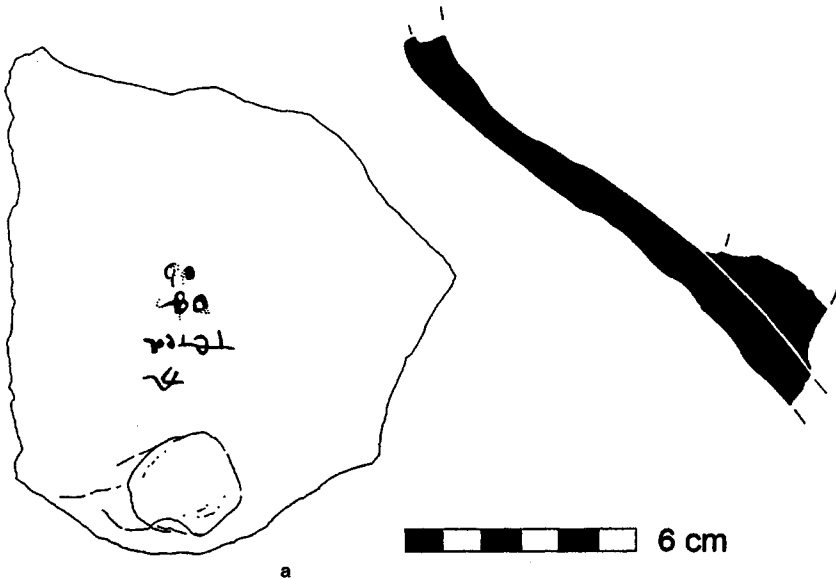

Figure 11. (a) Dipinto with "tetra" inscription and (b) sherd with bird stamp and palmettes

on the Red Sea suggests that paganism in the remote regions of the empire was not quite as dead as Justinian might have wished.

Much remains to be done. The bones, teeth, and other animal remains in particular need to be retrieved from storage in Qufi and analyzed. If at all possible, the

floral material should be studied as well, and documentation for the dipinti, stamps, and sherds must be completed, hopefully during a study season in 2001. The trenches may be backfilled, but further discoveries surely await.

As usual, thanks are due to many people: Gene Gragg, Director, John Sanders, Michelle Wong, and Donald Whitcomb of the Oriental Institute; Dr. Gaballa Ali Gaballa, Dr. Mohammed Sughair, and Mohammed Nasr of the Supreme Council of Antiquities; Mr. Mohammed el-Hinnawi, Dr. Abd el-Aziz, and Dr. Gaber Naim of the Egyptian Geological Survey and Mining Authority; Robert K. Vincent, Cynthia Schartzter, and Jaroslaw Dobrowolski of the Egyptian Antiquities Project; Mark Easton and above all Mme Amira Khattab of the American Research Center in Egypt; Raymond Johnson, Ahmad Harfoush, Sue Lezon, Yarko Kobylecky, and especially Tina Di Cerbo of Chicago House in Luxor; and Worldwide Chain Store Systems. Support for the project was provided by the National Geographic Society, the Egyptian Antiquities Project, Mrs. Catherine Novotny-Brehm, Pennzoil, Mr. and Mrs. H. I. Meyer, Dr. Robert K. Smither, Diana Grodzins, and Leila Foster.

DHAMAR PROJECT

Tony J. Wilkinson

This report should be detailing the results of the 1998 field season conducted in February and March 1999. Unfortunately, owing to circumstances following the kidnapping of tourists in late 1998, and a United States government travel advisory notice against visiting Yemen, the winter 1999 season was postponed until fall 1999. However, we were able to take advantage of the available time to prepare for publication some of the materials recovered from earlier field seasons. Consequently, just as the results from the 1998 field season were appearing in the journal *Arabian Archaeology and Epigraphy*, major articles synthesizing our knowledge on the Bronze Age pottery from highland Yemen and the Iron Age and Himyarite architecture were being prepared respectively by Christopher Edens and Eleanor Barbanes. In addition senior graduate students Joseph Daniels and Colleen Coyle were able to critically examine inscriptional evidence (Daniels) and obsidian sourcing (Coyle) from the Dhamar area.

Since our return from the field, results of the geoarchaeological analyses are starting to appear. This is enabling us to make more sense of the sequence of environmental change as well as interactions between early highland communities and the environment. The extraordinary length and scale of the Yemeni sedimentary sequences is well illustrated by figure 1, which shows an expanded diagrammatic view of the stratigraphic succession behind the destroyed Himyarite dam of Sedd adh-Dhra'ah II (for a photograph, see *1995/96 Annual Report*, p. 75, fig. 4). This sequence, which represents virtually the entire sweep of the Holocene (i.e., the last

ARCHAEOLOGY

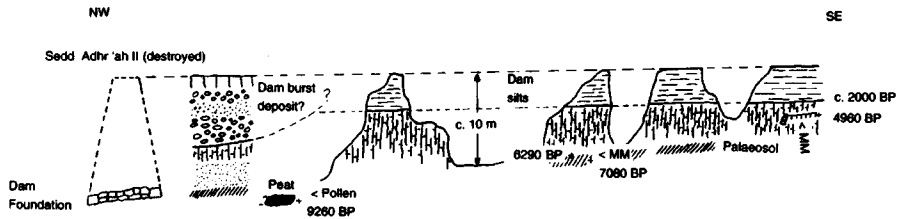

Figure 1. Diagrammatic section behind the broken 2,000 year old dam of Sedd adh-Dhra'ah showing sedimentary stratigraphy from the last 10,000 years

10,000 years), commences with thick deposits of peat at the base that have been dated by radiocarbon to 9,260 years before present. These peats are now being analyzed for their contained pollen by Caroline Davies at Arizona State University. The peats being black and humus-rich appear to have accumulated in a verdant environment during which conditions were favorable for the accumulation of organic matter. Similar conditions, albeit perhaps somewhat less verdant, continued into the period between 6,000 and 7,000 years ago when the characteristic humus-rich (but not peaty!) palaeosol must have accumulated in a rather plant-rich valley floor environment. After this, conditions in the valley changed so that they were less favorable for the accumulation of organic material and humus so that silts and clays started to fill up the valley floor. As discussed below, this sedimentation probably results from a combination of increased atmospheric drying and increased human activity. It was during the later stages of the so-called Neolithic moist interval that a small valley floor terrace, already mentioned in the *1997/98 Annual Report*, must have been built. This low wall, dated by radiocarbon to around 3735 BC (4900 BP, fig.1) represents one of the earliest dated terraced fields in Arabia, but unfortunately, owing to its great age, the soil that accumulated behind the terrace wall has some of the characteristics of a natural soil. This information comes from the soil micromorphological studies of Charly French, a geoarchaeologist from Cambridge University, who has examined selected soils from the project under the microscope to obtain a worm's-eye view of their structure and history. The accumulation of silt and clay in the valley floor continued after the terraced field had been covered. Then, during Himyarite times (roughly contemporary with the Roman period), a major dam was built, behind which accumulated a few meters of silts and sands. Finally, a major catastrophic flood appears to have swept away the dam down to its foundations and left in its wake massive boulder and cobble beds (dam burst deposit in fig. 1).

There now seems little doubt that in southern Arabia the middle Holocene, that is from about 10,000 to 5,000 years ago, was significantly moister than today. However, our research is showing quite clearly how atmospheric processes and human activity interacted. The humus-rich buried soils (palaeosols) are proving to be particularly interesting because on face value they appear to have been formed during a moister climate that encouraged the growth of more vegetation than is possible today. The soils did not, however, simply accumulate in a pristine environment bereft of human activity. Instead, soil micromorphological studies by Charly French demonstrate that some of these soils show signs of considerable reworking in the presence of human activity, a point which is confirmed by the frequent presence, during

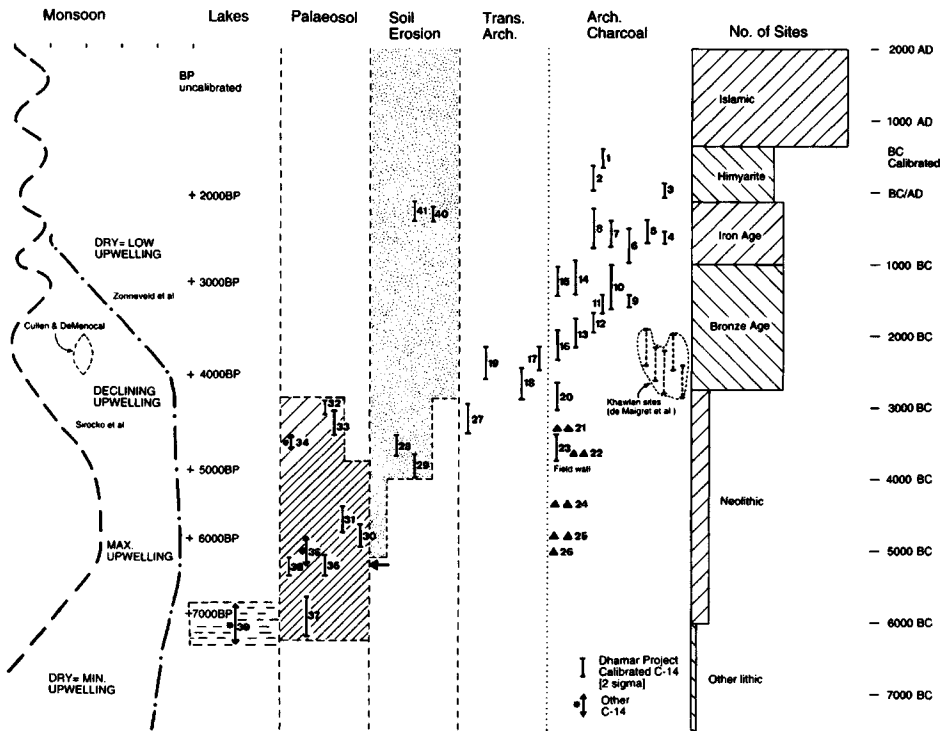

Figure 2. Settlement and environment in highland Yemen: Climate to the left, settlement periods to the right, sedimentary stratigraphy and radiocarbon-dated archaeological horizons in the central columns (drawn by Eleanor Barbanes)

field inspection, of obsidian artifacts, flecks of charcoal, and even food waste in the form of animal bones. Thus, these buried soils that developed in the apparently pristine environment of highland Yemen during the Neolithic were often intimately associated with human activity.

Figure 2 illustrates the ambiguity of interpreting the combined effects of human activity and environmental change, the interpretation of which is seemingly tinged with politics. On the left-hand side of the diagram we can see increased atmospheric moisture as recorded in cores in the bed of the Indian Ocean, whereas to the right is illustrated the increasing number of archaeological sites through time. The second column (Palaeosol: hatched) indicates the dates obtained by radiocarbon of the ancient dark humus-rich soils, while the third column (soil erosion: stipple) indicates the silty and sandy soils that accumulated usually on top of and after the old soils, frequently behind the walls of field terraces. In addition, archaeological horizons dated by radiocarbon are shown by the vertical lines in the column designated: Arch. Charcoal. Looking from the left, the buried soil (palaeosol) clearly accumulated when conditions were wetter, and the distinctive interface between the buried soils and the overlying soil erosion occurs at a time when, according to the ocean cores, conditions were getting drier. This therefore dates from a little before or after 4,000 years ago in radiocarbon years. In other words with drier conditions there was

ARCHAEOLOGY

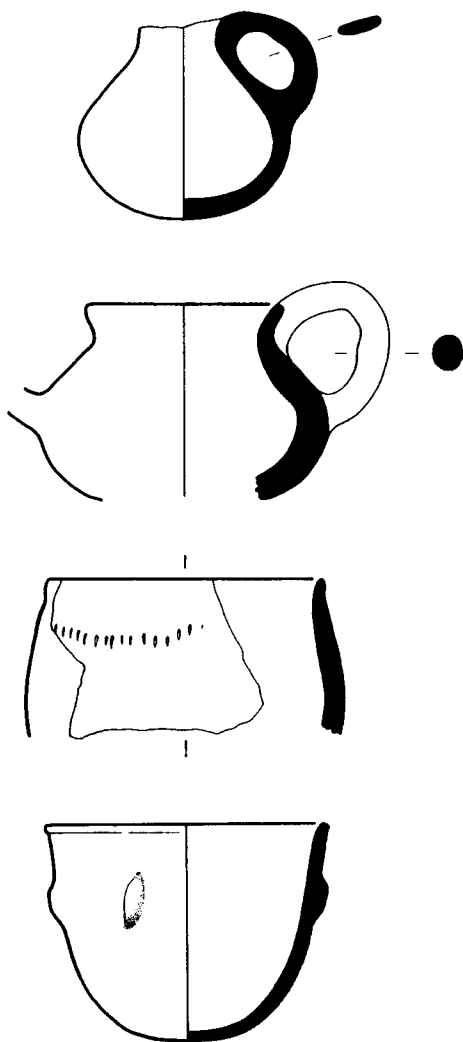

Figure 3. Some of the smaller late Bronze Age vessels from Kharraib (DS 228; drawn by Eleanor Barbanes)

less vegetation to retain soil on slopes and soil erosion resulted. On the other hand, looking from the right of the diagram we see that the same horizon is “explained” by the abrupt increase of human occupation in the Bronze Age, as indicated by the number of sites with the characteristic Bronze Age pottery. Such human activity, by disturbing soils on slopes and physically removing vegetation, would have encouraged soil erosion. Taking a more magisterial overview, we are therefore forced to conclude that neither human activities nor climate were the sole determinant of the change from humus-rich soil to accumulation of silts and loams. Rather it seems that the increase in human population and activity in the face of a drying climate might have resulted in this major sedimentary transition.

Owing to the still preliminary nature of our ceramic chronology, however, the graphical representation of sites in figure 2 is still oversimplified. Because all sites of the rather lengthy Bronze Age, which extends from the early third millennium BC to the late second millennium, are combined together, we get an overly steep increase in site numbers in the Bronze Age. However, recent analysis of the ceramic sequence by Christopher Edens suggests that there are probably three phases of the Bronze Age in the

Dhamar area (albeit with a significant amount of spatial variability). The earliest phase, belonging to the later part of the third millennium is represented by the site of al-Sibal, excavated by McGuire Gibson in 1995; the second phase by Hammat al-Qa, excavated by Christopher Edens; and the third phase by Kharraib, again excavated by McGuire Gibson and reported in the previous *Annual Report*. Examples of the rather distinctive later Bronze Age ceramics are indicated in figure 3. The full late second millennium BC assemblage, although still distinctively “Bronze Age” in its types, is starting to exhibit some of the characteristics of the Iron Age pottery of the region. Although we are still some way off from having a full ceramic record, we are now reaching the point where the known ceramic horizons are starting to exceed the gaps in the sequence.

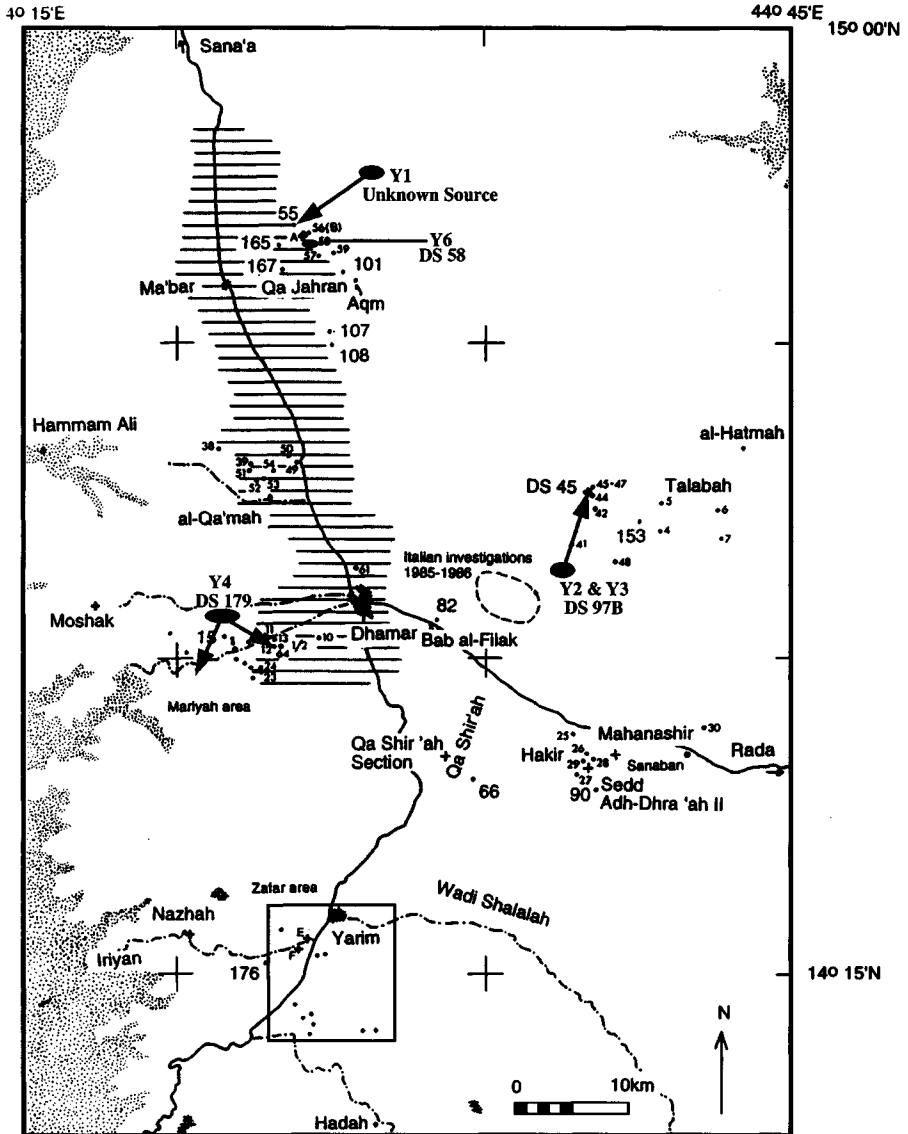

Figure 4. Preliminary map of obsidian trade and sources (data from J. Blackman, compiled by C. Coyle)

One of the few natural resources in the Yemen highlands around Dhamar, apart from soil and rainfall, is obsidian. This form of volcanic glass, because it can be chipped into a sharp concoidal fracture, is ideal for the manufacture of chipped stone implements. Even more attractive to archaeologists, the volcanic flows or plugs that yield the obsidian usually have distinctive chemical signatures that can be measured by techniques such as instrumental neutron activation analysis. As a result of the application of these sourcing techniques it is possible to trace artifacts to spe-

ARCHAEOLOGY

cific sources of obsidian. At present, we are in the initial stages of a study of obsidian sourcing in the Dhamar area, but some preliminary results are starting to appear. Analysis, undertaken by Jim Blackman of the Smithsonian Center for Materials Research and Education, Washington, DC is beginning to demonstrate that individual obsidian artifacts from specific sites can now be traced to specific outcrops or obsidian sources. In figure 4, compiled by Colleen Coyle, the sources are shown as solid ellipses, whereas arrows lead away from the sources to nearby sites that received obsidian from those same sources. For example, the Bronze Age site of DS 45 appears to have received at least some of its obsidian from the nearby volcanic mountain of Jebel al-Lisi (source Y2/Y3), while the Iron Age site of DS 15/17 received its obsidian from a much more dispersed source a few kilometers to the north (source Y4). More significantly in terms of interregional exchange, sites well outside the region, in the Wadi al-Jubah some 110 km to the northeast, received at least some of their obsidian from sources in the Dhamar area. Thus source Y2/Y3 contributed a single artifact to the site of Hajar ar-Rayhan I (in Wadi al-Jubah) and also site DS 55 shown in the northern part of figure 4, shared the same (but unknown) source as artifacts from Hajar ar-Rayhani. It is very likely that this source is also in the Dhamar area.

The archaeology of the Dhamar region therefore continues to take shape, both as a result of traditional modes of fieldwork, and by scientific analysis. Future work will therefore attempt not only to elaborate the archaeological and environmental chronology, but also to extend the record back into the early third, fourth, and fifth millennium BC, a period of which we still have only a very vague impression. Specifically, in the forthcoming season scheduled for October and November 1999, we will continue to map details of buildings within the Bronze Age sites, the scope of the obsidian analysis program will be extended, we will attempt to obtain further details on the date of initial construction of terraced fields, and finally, more time will be expended recording inscriptions, both monumental and informal, in order to build up the historical database for the region during the Himyarite period.

DIYALA OBJECTS PROJECT

McGuire Gibson

During the 1930s, the Oriental Institute carried out an ambitious program of excavation in the Diyala Region, an area to the north and east of Baghdad. The project yielded an extraordinary record of architecture and stratified artifacts, including thousands of cuneiform tablets. Although much of the work was reported in a series of Oriental Institute Publications, the 12,000 or so "miscellaneous objects" have yet to be published. Although the term "miscellaneous" may make these objects seem insignificant, they include very important categories of artifacts. Among these ob-

DIYALA OBJECTS PROJECT

jects are metal vessels, tools, and weapons, baked clay figurines and plaques, beads and other jewelry, bone and shell objects, stone mace-heads and other stone tools, stamp seals, and clay seal impressions. By making available the information on these categories of objects, to complement the data available in the already published volumes on temples, public buildings, and houses, as well as those devoted to pottery, statuary, and cylinder seals, scholars will be able to create better syntheses of the ancient Diyala Region. Without this missing information, syntheses can only be intriguing but incomplete pictures.

The Diyala Objects Project reached a milestone during the past year. With the database finally in a reasonably correct form, we were able to delve deeply into several categories of objects and begin to analyze the material in detail. Stone vessels and inlay pieces of bone, shell, and ivory have been worked on by Claudia Suter, who has been considering the inlays from an artistic and archaeological viewpoint; meanwhile David Reese has been working up the shell inlays in terms of species from which the bits were cut. A graduate student assistant, Colleen Coyle, has analyzed the stone weights. She has had the cooperation of Andrew Davis of the Fermi Institute in using the scanning electron microscope to identify the stones of which the weights are composed.

Clemens Reichel has moved ahead on a special project that shows the potential of the databases. For more than two years, Reichel has been working on all the objects from one set of buildings, the so-called "Gimilsin" (really Shu-Sin) Temple and the Palace of the Rulers of Tell Asmar (ancient Eshnunna). This complex of buildings in the earliest stage featured a temple dedicated to the worship of Shu-Sin, the divine king of Ur, who ruled much of what is now Iraq at about 2200 BC. Over the next 150 years, this complex went through four or five major renovations, with new buildings constructed on the demolished ruins of the earlier ones. In the earliest of the Diyala reports, Henri Frankfort and his team presented a set of plans and reconstructed views, with indications of the material found in the buildings. But investigation has shown that the publication was far from complete. Most important, although some cuneiform documents were published, the vast majority of the 1,100 or so texts from the different versions of these buildings were not read, nor have they been thoroughly analyzed. Another very important set of omitted objects is a total of more than 200 clay sealings, that is, lumps of clay that had been used to seal jars, baskets, bags, and other containers as well as doors. These sealings, once they were in place, were then stamped over with cylinder seals. Often the seals were inscribed with the names and titles of the owners, and sometimes the name of their fathers. Determining exactly where a sealing had been



Kh. VII 247

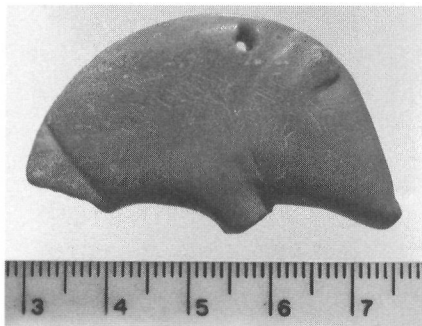

Ag. 35:974

ARCHAEOLOGY

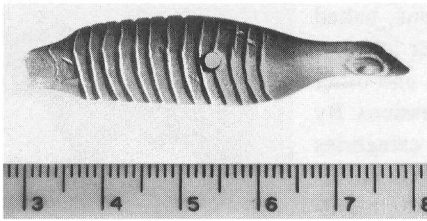

Ag. 36:363

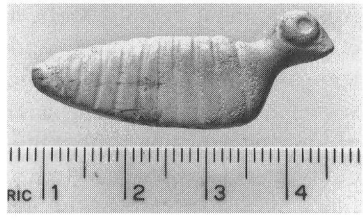

Ag. 36:152

found in the buildings may give indications of which rooms were used to store precious commodities and had to be locked and sealed. Such information could also give an indication of where specific officials worked within the complex. Tablets with names of officials and details of the movement of supplies or goods may allow one to strengthen the picture of the administration at work and may even show “paper trails” (or rather “clay trails”), as a tablet went from one office to another or to the governor or king in another part of the building.

It is in seeking just this kind of information that Reichel has made tremendous progress. By using the general project’s databases and adding to them new information from the objects and tablets found within the complex, he can argue very convincingly that the original dating of specific levels of the complex must be revised. He has suggested some intriguing correlations between archaeological evidence and historical data on changes of dynasty. With the sealings alone, he has been able to work out genealogies of officials that span four generations, showing that even though the Ur III kings lost the Diyala and local kings took over, the families of officials continued in place. Dynasties come and dynasties go, but bureaucrats go on forever.

The new ways in which Reichel is using computers in his work has been recognized by his receiving a Walsh Award, given by the University to encourage innovative use of computers.

With the end of funding from a 3-year grant received in 1995 from the National Endowment for the Humanities, we have been anticipating a drastic slowing of the project. Claudia Suter, the project coordinator, has left the project to pursue her career in Europe. Her departure would have meant that only student assistants, working a few hours a week on whatever funding we might raise in-house, would have been carrying on the piecemeal analysis of individual categories of objects. But a

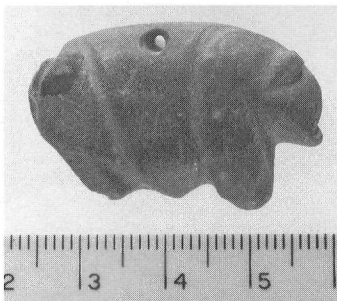

Is. 34:130

proposal submitted to the provost’s office has resulted in a grant, coming into effect on 1 July 1999, to help complete the project. Most of the funding will go to support Clemens Reichel and Colleen Coyle, with some money allocated to upgrading equipment and programs. This grant means that we will continue to make substantial progress on the project. There is another element leading to success, however. The project has benefited in a variety of ways from an extraordinary group of volunteers. Joyce

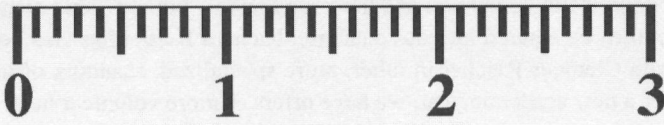

As. 30: T.226 (obv.)

ARCHAEOLOGY

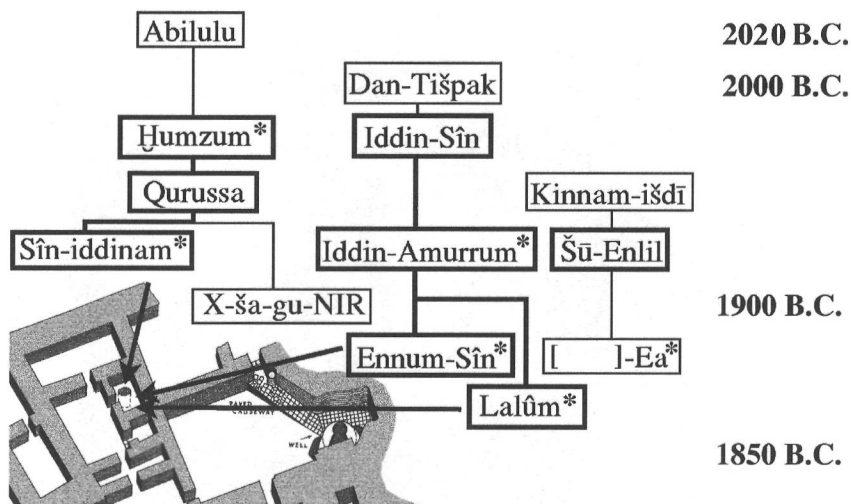

Genealogies of officials in complex of buildings at Tell Asmar (ancient Eshnunna)

Weil, a longtime employee of the Computer Center of the University, has been steadily scanning photographs of objects so that we can include them in the database. Helaine Staver worked alongside Claudia in the meticulous checking for accuracy of the database and now searches out information on specific problems in old records in the Institute's archives. Betsy Kremers has taken hundreds of new photographs of Diyala objects that are in the Oriental Institute collections. With her negatives, we go to Helix downtown and have the images "burned" onto computer disks, which can then be entered into our database. Richard Harder has also been working closely with Clemens Reichel in other, more specialized, scanning of images. And as we enter a new academic year, we have offers of more volunteer help. There is no way to calculate the value of such volunteers, but their work is extraordinarily important. We wish to thank them for their time, expertise, intensity, and good humor.

EPIGRAPHIC SURVEY

W. Raymond Johnson

On 15 April 1999 the Epigraphic Survey successfully completed its seventy-fifth six-month field season. The documentation and conservation efforts of the Survey during this anniversary year were concentrated in the precincts of Medinet Habu and Luxor Temple. In the Eighteenth Dynasty Amun Temple at Medinet Habu the inking and collating of drawings continued in the painted chapels of Hatshepsut and Tutmosis III, and conservation was resumed on the rooftop over the sanctuaries.

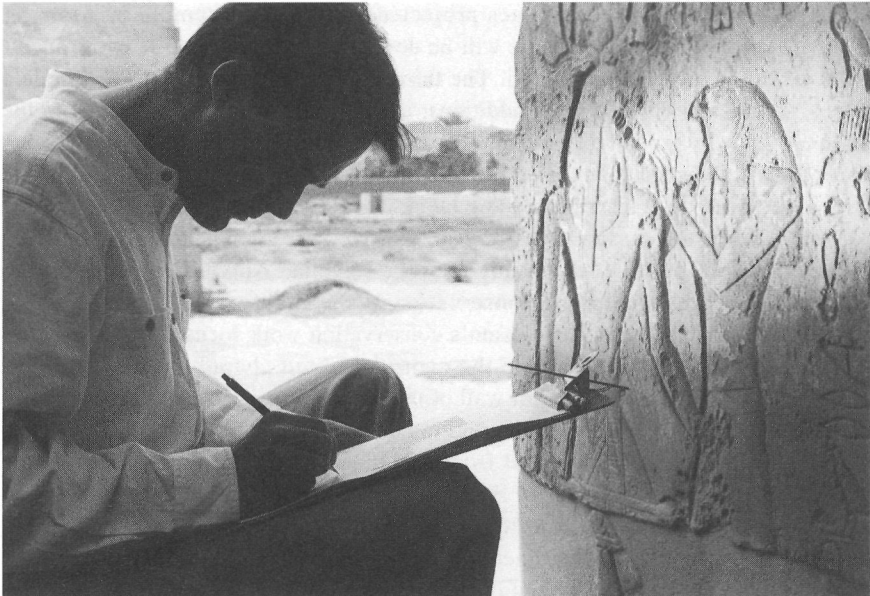

Figure 1. Epigrapher J. Brett McClain collating pillar in bark sanctuary of Eighteenth Dynasty Amun Temple, Medinet Habu. Photograph by Sue Lezon

The inscribed southern well of Ramesses III was completely photographed, and testing was done to determine the extent of the salt damage to the decorated wall surfaces. Across the river at Luxor Temple reference photography and statue cleaning continued in the Colonnade Hall, and conservation was resumed on the block fragments in the southeast blockyard. The Survey's latest volume, and a monument in itself, *Reliefs and Inscriptions at Luxor Temple, Volume 2: The Facade, Portals, Upper Register Scenes, Columns, Marginalia, and Statuary in the Colonnade Hall* (OIP 116), was published in the fall.

Eighteenth Dynasty Temple at Medinet Habu

From 15 October 1998 to 15 April 1999 the Epigraphic Survey staff of artists and epigraphers continued penciling, inking, and correcting facsimile drawings of the painted reliefs in the small temple of Amun, on the pillars that surround the bark sanctuary, and on the bark sanctuary itself. Four new staff members were trained on-site: two epigraphers, graduate students Hratch Papazian and J. Brett McClain (fig. 1); and two artists, Bernice Williams (wife of Senior Epigrapher Ted Castle) (fig. 2) and Carol Abraczinskas. I am pleased to report that all four are returning for the 1999/2000 season. Eleven drawings were penciled at the wall by artists Sue Osgood, Margaret De Jong, Bernice, and Carol, mostly in preparation for work over the summer. Twenty-nine drawings were checked at the wall by epigraphers Ted Castle, Debbie Darnell, Hratch, Brett, and the art staff during the course of the season, and seven drawings await the final Director's Check. The drawings of the painted chapels of Hatshepsut and Thutmose III, the earliest portion of the temple, and their facade have now been successfully completed (fig. 3) and await one final paint collation after the reliefs have been completely cleaned. They will be pub-

ARCHAEOLOGY

lished in the first of three volumes projected for the small temple of Amun at Medinet Habu. The second volume will be devoted to the Thutmoside bark sanctuary area and miscellaneous graffiti. The third volume will document the temple's Twenty-fifth Dynasty, "Kushite" additions; a final volume will be dedicated to the Ptolemaic and Roman additions. This season Staff Photographer Yarko Kobylecky, assisted by Ellie Smith, completed the photography of the west interior wall of the bark sanctuary and the inscribed ceiling blocks for the second volume.

The 1998/99 season saw the third year of a five-year grant generously approved by the Supreme Council of Antiquities and the Egyptian Antiquities Project of the American Research Center for conservation of the Eighteenth Dynasty Temple complex at Medinet Habu. This season's conservation work focused on the rooftop of the Thutmoside temple, inside the central painted chapel and the northern "King's Chapel," the south exterior wall of the bark sanctuary, the northern ambulatory of the bark sanctuary, and the north Ptolemaic wing.

Stonecutter Dany Roy worked from 15 January to 15 April and resumed the roof restoration begun last season. He continued to clean all of the cracks between the stone roof blocks carefully with a compressor and vacuum cleaner and sealed the roof blocks over the bark sanctuary with a mortar compound tempered with crushed brick, a technique utilized in restoration work at Karnak and approved by the Supreme Council of Antiquities and the Egyptian Antiquities Project. On the north side of the sanctuary area, Dany restored and replaced thirteen roof block slabs originally dating from the time of Ptolemy VIII, removed during restoration work earlier this century and not replaced. He also identified three original stone slabs in the debris on the roof and put them back in their original positions. The new roof blocks were obtained from the same quarry as the original blocks, Gebel Silsileh, and were custom-cut (fig. 4) and shaped by Dany based on a photograph of the roof taken in the 1930s and published in U. Hölscher, *The Excavation of Medinet Habu, Volume 2: The Temples of the Eighteenth Dynasty* (OIP 41), page 8, figure 7. Sincerest thanks are extended to François Larché, Director of the Franco-Egyptian Center at Karnak for expediting the acquisition of the sandstone. The replacement of the roof blocks restores an ancient drainage channel that directs water off the roof through a Ptolemaic period rainspout, thereby ensuring the protection of the decorated rooms below from future rainstorms. Dany also recut and replaced six Ptolemaic roof blocks over the facade of the sanctuary entrance and three more above the bark sanctuary south wall, thereby eliminating two additional areas of water leakage. In all he relaid twenty-five stone blocks, cutting and shaping twenty-two new stones from scratch.

Egyptologist/artist Christina Di Cerbo continued to measure and draw all of the bark sanctuary roof blocks and plotted all of the details on a master plan of the entire Eighteenth Dynasty Temple roof. She extended her plan this season to include the Kushite pylons (fig. 5) and Ptolemaic additions to the Eighteenth Dynasty Temple and plotted all of the traces of now missing architectural elements from those structures where they joined the Eighteenth Dynasty Temple roof. Photographer Yarko Kobylecky continued his reference photography of the roof areas before, during, and after cleaning and infilling.

This season saw the inauguration of a new phase of the Eighteenth Dynasty Temple conservation program. Painting and stone conservator Lotfi Hassan (fig. 7), whose previous work experience includes cleaning the tomb of Ramesses II's queen Nefertari with the Getty Conservation Institute, began the careful cleaning of the painted reliefs in the Eighteenth Dynasty Temple sanctuary from 15 October 1998 to 15 January 1999, and completed about 90% of the north interior wall of the central room. This is an area where incursions of rainwater in the mid-1990s had activated the migration of salts trapped in the walls, staining the reliefs. Lotfi was able to remove all of the surface salt, along with a fair amount of soot and dirt. The phases of the conservation process were:

1. Cleaning, manual and chemical
2. Desalination
3. Consolidation of the color layers and stone degradation surface
4. Repointing of the missing parts and micro and macro cracks
5. Final protection of the wall paintings' surface with acrylic resin

Lotfi expanded his operation late in December to include the exterior south wall of the bark sanctuary where rain-washed mud from the roof obscured some of the reliefs. This mud has now been removed, allowing artist Sue Osgood to transfer newly exposed details to the drawings-in-progress of those wall sections. From 15 March to 15 April Lotfi removed the salt from the upper, south interior wall in the "King's Chapel," stained during the same rainfall, and tested different mortar infills between the stone wall courses.

Lotfi also consolidated with the silicate Wacker OH some of the large sandstone floor blocks of the small Amun temple exhibiting signs of decay, one in the northern ambulatory of the bark sanctuary, one in the eastern ambulatory, and three in the Ptolemaic wing addition to the north of the bark sanctuary. This work will continue next season.



Figure 2. Artist Bernice Williams penciling photographic enlargement in bark sanctuary ambulatory of Eighteenth Dynasty Amun Temple, Medinet Habu. Photograph by Sue Lezon

ARCHAEOLOGY

Southern Well of Ramesses III

In January large-format photography of the inscribed southern well of Ramesses III, one of the priorities for this season, was launched in earnest. This well is one of two located on either side to the south and north of the mortuary temple used in Ramesses III's time to obtain sacred groundwater for purification rituals. The preserved area of the southern well consists of a short entrance corridor, an inscribed descending stepped passage to the right, and a third descending corridor to the left, now completely underwater. The last corridor leads to a submerged doorway that opens into the well shaft itself, which is open to the sky. While the carved decoration of the submerged corridor, although inaccessible at present, is in an excellent state of preservation, the reliefs of the first descending corridor, only partly submerged, are completely covered with salt, in some places up to 3 cm thick, with much of the present decoration now extremely difficult to see.

Due to the confined space within the well, the fragile nature of the reliefs on the walls, and a water level more than a meter and a half higher than in the 1930s, the logistics of photographing what is left of the interior decoration (Nile gods bringing sacred water up from the well, and purification scenes) were difficult to say the least (fig. 6). To facilitate the photography, Senior Epigrapher Ted Castle, with the assistance of Chicago House carpenter Shayib Kyrollos Abadir, designed and built a series of wooden "pier" sections that extend into the main descending passage just above water level and provide a firm footing for the camera tripod and photographer. These sections can be dismantled and removed when the well is not being worked on.

The east wall of the entryway is in an active state of decay. The middle course of the wall is being squeezed between the weight of the upper course and the unyielding lower course, causing the upper lintel stone to split in half and the whole left side of the well entrance to subside. Stabilization of this area is being undertaken now with the kind assistance of the local Supreme Council of Antiquities Gurna Inspectorate. Three large-format negatives of the well's interior taken between 1939 and 1946/47 were located in our Photographic Archives, and one of the shots shows the interior east wall, now damaged, and the exterior lintel block, before serious subsidence had occurred. These photographs will supplement a complete set of 35 mm reference photographs taken by former Staff Photographer Tom Van Eynde in 1986 that preserve numerous details subsequently destroyed by the salting of the walls. The 35 mm negatives, already scanned, will be joined into full wall montages using Adobe Photoshop software. Both sets of earlier photographs will be compared to the large-format photographs generated this season to determine the rate of decay of the structure from the 1930s till now.

When Yarko and Ellie Smith were finished with the arduous task of photographing every square centimeter of accessible, decorated wall surface in the well, a truly noble accomplishment, conservator Lotfi Hassan did some sample cleaning of the salt-covered, inscribed wall surfaces to determine how much stone was preserved beneath the thick layer of salt (fig. 7). He found differing amounts of preservation in different areas: on some wall surfaces the inscribed stone was intact beneath the salt, in others only partly preserved, and in others completely missing, with the salt alone preserving an impression of the carved decoration. We will con-

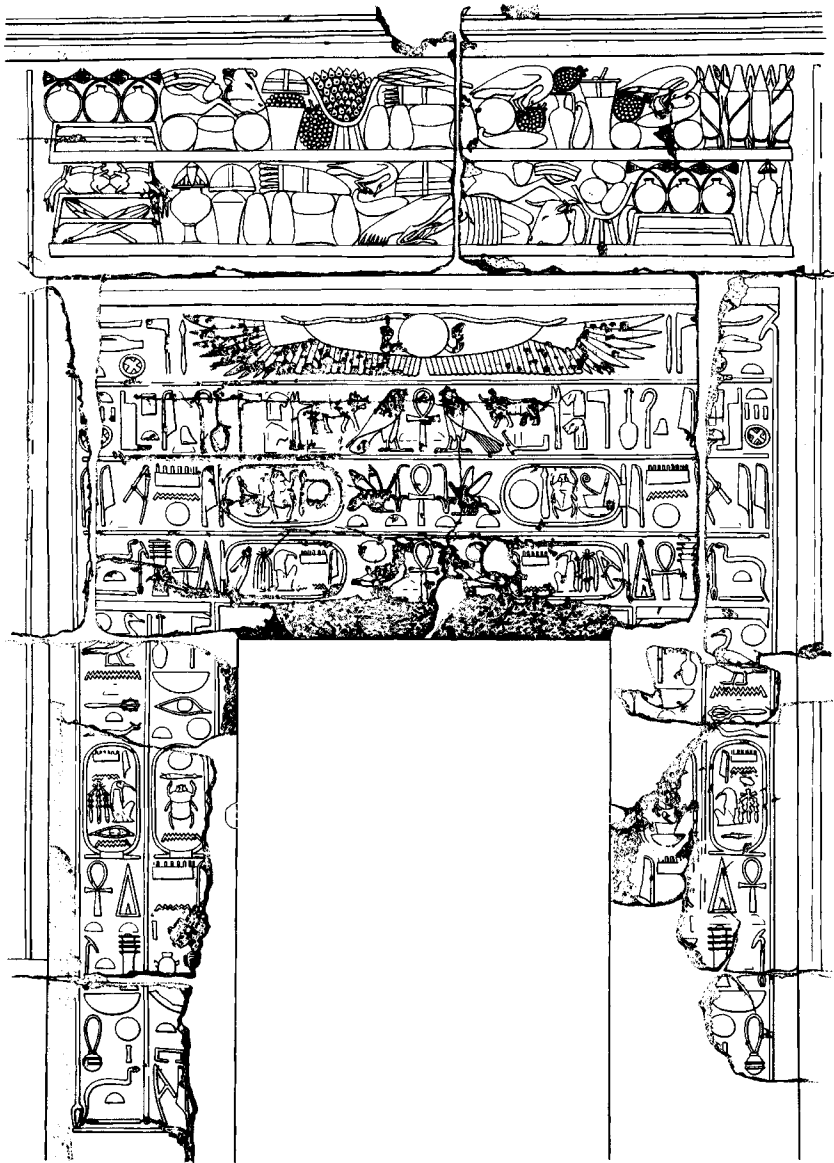

Figure 3. Inscribed doorway leading from sanctuary Room I to Room IV, small temple of Amun at Medinet Habu, time of Hatshepsut and Thutmosis III. Facsimile drawing by Susan Osgood. Photograph by Yarko Kobylecky

duct more tests and cleaning next season in an effort to lessen the corrosive action of the salt on the walls.

Luxor Temple

The Survey's latest and long-awaited volume, *Reliefs and Inscriptions at Luxor Temple, Volume 2: The Facade, Portals, Upper Register Scenes, Columns,*

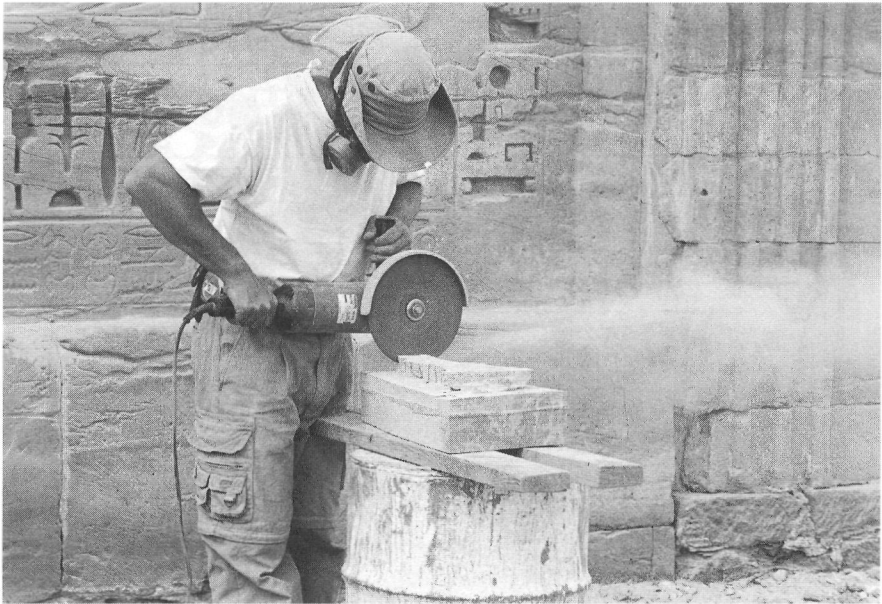

Figure 4. Stonecutter Dany Roy cutting new sandstone block for Eighteenth Dynasty Amun Temple roof, Medinet Habu, March 1998. Photograph by Yarko Kobylecky

Marginalia, and Statuary in the Colonnade Hall (OIP 116), was finished and published this past fall. This volume completes the Epigraphic Survey's documentation of the standing wall remains of the great Colonnade Hall at Luxor Temple, begun at the height of Egypt's empire period by Amenhotep III and finished by Tutankhamun, a magnificent and increasingly fragile structure. James Henry Breasted would be pleased; in correspondence dating from 1932 he expressed the wish to the first Chicago House Field Director, Harold Nelson, that the Colonnade Hall be included in the publication program of the Epigraphic Survey because of its condition, already precarious even then. We have tried to make up for lost time and are very proud of this milestone in the history of the Epigraphic Survey, but we are not entirely finished there yet; a third volume in the series will be dedicated to upper-register decorated stone fragment groups, the analysis of which is still in progress, and an architectural study, which will resume in a year.

This season marked the fourth year of a five-year grant generously approved by the Supreme Council of Antiquities and the Egyptian Antiquities Project of the American Research Center for the treatment and consolidation of deteriorating decorated stone fragments at Luxor Temple. Conservator John Stewart, Ph.D., returned for a week in January to consult with Hiroko Kariya in the continuation of the project, while Hiroko worked from 11 January to 13 February. All one thousand five hundred and forty fragments recorded on our computer database were monitored for stability. Seventy-four sandstone blocks were physically strengthened with the Wacker OH consolidant in the expanded outdoor laboratory. One hundred eighty-four fragments are currently sheltered in a special, covered platform that protects them from rainfall and wind erosion, or on covered tables and shelves. Trial

desalination was performed on four fragments, which included testing of various poulticing materials. Salt crystals found on twenty-four fragments were sampled and identified.

This season Chicago House received permission from the Supreme Council of Antiquities to expand the Epigraphic Survey Fragment Project to include all of the decorated stone fragments stored around Luxor Temple. During the first half of the season a prefabricated conservation laboratory/office was constructed in the Epigraphic Survey blockyard to facilitate the treatment of the deteriorating fragments and to function as the “command center” for the new operation. Chicago House residents Helen Jacquet-Gordon and her husband Jean Jacquet, Tina Di Cerbo, and Hratch Papazian carefully surveyed the entire area along the east side of the Luxor Temple precinct (fig. 8). Tina then generated an excellent map of the area which conserva-

tors John Stewart, Hiroko Kariya, and I used to plot the expanded Epigraphic Survey blockyard and fragment treatment area. During the latter part of the season four new, damp-coursed storage mastabas made of baked brick (three 12 m in length and one 7 m in length) were constructed south of the conservation laboratory, extending the blockyard to the south; and six were constructed in the lower area to the north, east of the Amenhotep III sun court (each 15 m long). Special thanks to Engineer Mohsen Fahmy Seweha for supervising their construction. As fragments are sorted, photographed, and moved next season and in seasons to come, more mastabas will be built in both areas, and also to the west and north of the temple. The long, meter-wide storage platforms will house fragments sorted by style and content carefully stacked by category with all carved surfaces visible for later documentation and study. Deteriorating fragments will be isolated and placed on special mastabas for future consolidation. It is the goal of Chicago House to raise all of the fragments off the ground in order to protect the fragile material from the corrosive groundwater, and to develop a special database for the entire assemblage.

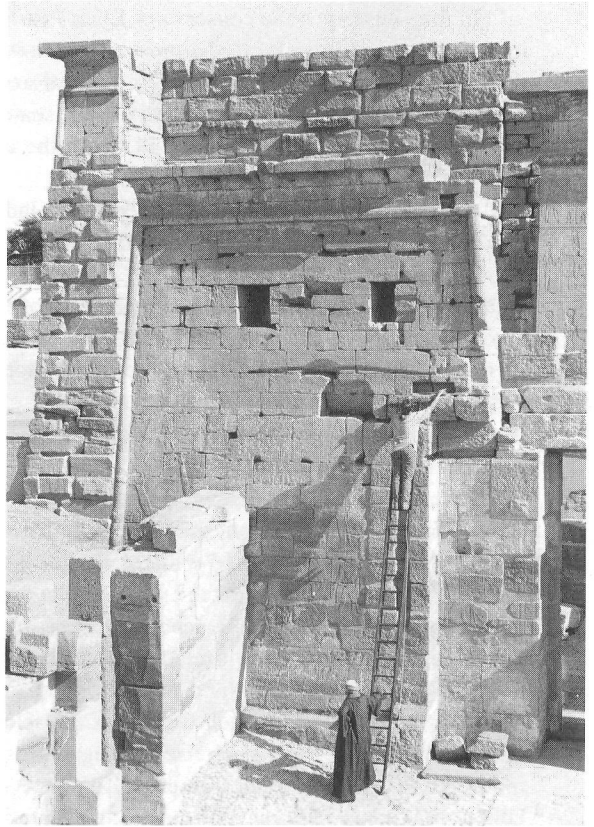

Figure 5. Epigraphic Survey Egyptologist and artist Tina Di Cerbo mapping Kushite (Twenty-fifth Dynasty) pylon, small Amun temple, Medinet Habu. Photograph by Yarko Kobylecky

ARCHAEOLOGY

In mid-January stone conservator Ellen Pearlstein returned to resume the cleaning of the colossal indurated-limestone statues in the Colonnade Hall (fig. 9), thanks to the continued generosity of friend and colleague Dr. Marjorie Fisher. Ellen concentrated this season on the small seated dyad of Amun and Mut on the east side of the hall (fig. 9) and will finish the cleaning of it and all three groups next year.

Continuous, above-average levels of salt-laden groundwater at Luxor Temple (and Karnak) and unusual humidity fluctuations during the last two seasons have resulted in dramatically increased salt efflorescence on the walls of the Colonnade Hall (fig. 10) and noticeable disintegration of the column bases. This is a truly alarming situation, in that the disintegration of some lower stone courses is now irreversible, and bodes ill for the future of the monument(s) if these conditions persist. Photographers Yarko Kobylecky and Sue Lezon took additional reference photographs in the hall this season to compare with earlier photographs of the same areas to help us gauge the rate of decay.

After long, on-site discussions with me and American Research Center in Egypt Director Mark Easton, the Honorable Daniel C. Kurtzer, United States Ambassador to Egypt, sponsored a historic meeting on 16 April at the United States Embassy residence to address the water and conservation problems in Luxor and to discuss possible solutions. Present at the meeting were the Director General of the Supreme Council of Antiquities Dr. Gaballa Ali Gaballa; Swedish Ambassador Sylvén; Bengt Hallmanns and Magda Houta of the Swedish engineering firm SWECO International; French Cultural Counselor Vincent Grimaud; Dr. Nicholas Grimal, Director of the French Archaeological Institute; Dr. François Larché, Director of the Franco-Egyptian Center at Karnak; Mark Silverman and Peter Argo of USAID; Dr. Chip Vincent, Director of the Egyptian Antiquities Project; and I, representing the Epigraphic Survey. The consensus was that we must all work together, but we must begin now because time has almost run out. A second meeting was held on 14 May in Luxor with the Governor of Luxor and the Ministry of Agriculture to discuss drainage measures that may be taken to lower the water table and slow down the decay. It was decided that engineering studies, sponsored by the Swedes, will begin immediately and will include both Karnak and Luxor Temples. It is only a first step, but it is a crucial one, and we owe a great debt to Ambassador Kurtzer for getting things started at this critical time.

Chicago House

1999 began on an upbeat note with the arrival on 1 January of Photographer/Photograph Archivist Sue Lezon and assistant Ellie Smith, who jointly oversaw the Photographic Archives for the rest of the season. Sue immediately resumed the monitoring and duplication of deteriorating nitrate negatives (39 were duplicated this year), and both worked on refining our new Photographic Archives database, designed by John Sanders and Jason Ur. Sue brought with her a special gift, generously donated by our friend and colleague Dr. Fred Giles: a Microtek Scanmaker 5, a 36 BIT reflexive and transmissive flatbed scanner with an 8 × 14 inch scanning area. This remarkable machine scans large and small format negatives as well as opaque photographs at 1,000–2,000 dpi, and Fred's magnanimity has allowed us to begin the

scanning of the 17,000 negatives in our Photographic Archives for burning onto CD-ROM for inclusion in our database a year ahead of schedule. Thus we are pleased to announce the inauguration of the Chicago House Imaging Center, an exciting new extension of our Photographic Archives, with sincerest thanks to Fred for opening that door for us. The Franco-Egyptian Center at Karnak has agreed to assist us in our task, having just finished the scanning of their own Photographic Archives, and Sue will be coordinating the scanning in both places. So far 248 4 × 5 inch Kushite block fragment negatives, 1,636 5 × 7 inch Luxor temple block fragment negatives, and 30 8 × 10 inch negatives have been scanned and burned onto compact disks (CD). By the end of the summer it is expected that the entire 5 × 7 inch holdings of the Epigraphic Survey will be scanned (painstakingly coordinated by Ellie), while the wholesale scanning of our 8 × 10 inch negative archive will begin next year. This year the only 8 × 10 inch negatives scanned were of the Ramesses III southern well, for computer joining and analysis starting this summer. In addition to the scanning, this season Yarko produced 102 large-format negatives, and the photographic team generated 148 sets of 35 mm negatives, all of which were carefully numbered and registered by Ellie.

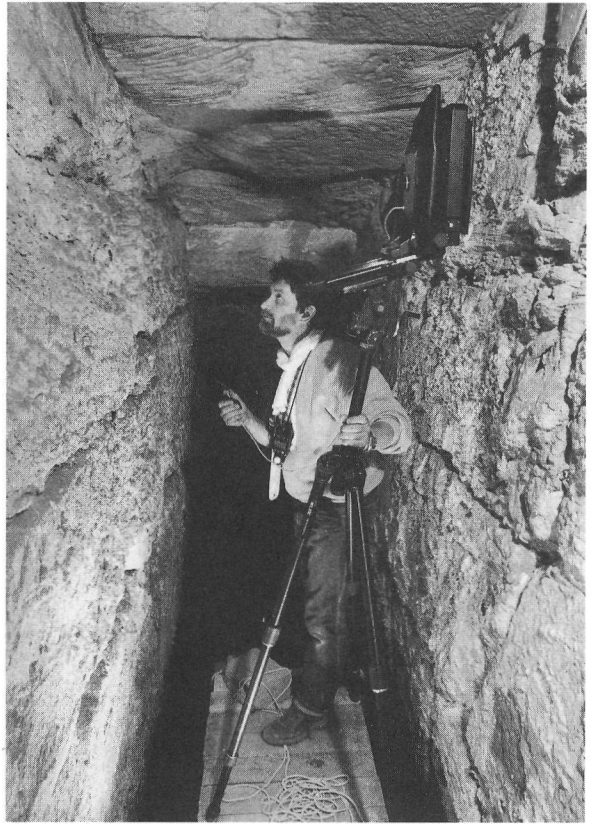

Figure 6. Epigraphic Survey Photographer Yarko Kobylecky photographing in southern decorated well of Ramesses III, Medinet Habu. Photograph by Sue Lezon

During the first part of December Senior Epigrapher Ted Castle, when not “at the wall,” oversaw the long-overdue review and updating of the Chicago House “Black Book,” our epigraphic operations manual, assisted by artists Sue Osgood, Margaret De Jong, and me. Initially written as a guide for the epigraphic copying and collating process at the beginning of our operation in Luxor, many of the procedures and conventions outlined in the book have been improved upon and refined considerably in recent years. Its updating was deemed particularly appropriate at this time, when so many new staff members are being trained and our whole operation in Luxor is being reviewed and reevaluated as the new millennium approaches; it will be a valuable reference work for all staff members, new and old alike, and I daresay we will always be tweaking it since the refining process is never-ending.

ARCHAEOLOGY



Figure 7. Epigraphic Survey conservator Lotfi Hassan test cleaning in southern decorated well of Ramesses III, Medinet Habu. Photograph by Yarko Kobylecky

Epigrapher and Chicago House Librarian Debbie Darnell continued to supervise the running of the library this season and registered 211 new acquisitions, upping our total holdings to 17,807 volumes and 410 journals/series. In January Assistant to the Director Carlotta Maher returned to Luxor for a two-month stint of her ever-gracious brand of development work, which included numerous stimulating library talks to interested individuals and groups, and hundreds of handwritten thank-you notes to our loyal supporters. Her personal touch is infinitely appreciated by all, and we are enormously grateful for every second she can be with us, not to mention all the work she does for Chicago House back home. In February Oriental Institute Visiting Committee member Nan Ray returned and kindly assisted Debbie in the library, Administrator Ahmed Harfoush in the main office, and Carlotta with the development work, and

was joined by her husband David later in the month, who helped staff engineer Jamie Riley with the house maintenance; they are a wonderful team. Oriental Institute Visiting Committee member Mary Grimshaw (fig. 11) joined the Chicago House staff for a month in February/March, generously assisted where needed in the library and Photographic Archives, and kept resident Egyptologist Dr. Henri Riad in line at the dominoes table after dinner. She is a very special addition to the house, and her help is very much appreciated. Our beloved Dr. Henri oversaw the library when Debbie was in the field, and continued to work through the Labib Habachi photographic archive, patiently identifying, sorting, and labeling hundreds of priceless photographs. Friends Helen and Jean Jacquet continued to lend their expertise where needed, whether it was surveying in the Luxor Temple blockyard, helping monitor the library, identifying photographs in the Habachi archive with Dr. Henri, or simply sharing their knowledge and experience with anyone who needed it. My heartfelt thanks are extended to all of our talented, dedicated friends and helpers. Without them, Chicago House wouldn't operate even a fraction as smoothly.



Figure 8. Epigraphic Survey Egyptologists Tina Di Cerbo and Hratch Papazian surveying east area of Luxor Temple prior to Epigraphic Survey blockyard expansion. Photograph by Sue Lezon

I am pleased to announce that Moataz Abo Shadi, CPA, who for the last two years, with the accounting firm of Coopers and Lybrand, guided us in putting together our new Financial Management System, in March joined the Chicago House team as Finance Director. He and accountant Marlin Nassim will now oversee all of the accounting for our Luxor operation, which will greatly ease the burden of the Chicago House Administrator (and Field Director!). Next season his wife Dalia and new baby Seif will join him at Chicago House during the season. We extend to Moataz and his family the warmest welcome and look forward to many years of happy accounting together.

We were also very grateful to have engineer Jamie Riley return for the last half of the season to assist longtime Chief Engineer Saleh Shahat and me with the never-ending maintenance of the Chicago House house and grounds. Last spring it became clear that we had to face some major house repairs if we were going to be shipshape for the new millennium. Slow leaks in the southwest corner of the house required the replacement of all of the plumbing in five suites of rooms over the summer after we left, and the eastern dining room wall, severely damaged by the leak, had to be repaired and repainted in October. Another project requiring immediate attention was the residence courtyard; over Halloween the tiles were all carefully pulled up, a proper concrete underpinning was laid, and new tiles were laid down. In November we had to reseal and retile the roof over the north library wing and librarian's office, with the new tiles laid at a proper pitch to direct rainwater to the rainspout on the east end of the roof. After his arrival, and with the help of our friend Engineer Girgis Samwell, Jamie supervised the sealing and retiling of the southern library roof, and the sealing of the expansion joint high up above between the old and new

ARCHAEOLOGY

library halls. He supervised the installation of a new kitchen drain system, the repair of the solar water heating unit over the back service area, and another unit over the darkroom. Jamie also coordinated the laying of a new, multiple-line telephone cable through the garden, encased in an insulated pipe for protection and buried a meter deep. Next season he will reapply all of the insulation on the hot water pipes connected to the solar heaters on the residence roof; the original insulation has been completely pecked to pieces by crows who have been using the shiny material for nests ever since it was first applied! It is great to have someone around who can deal with all of this, and his presence is much appreciated by us all, but especially by me.

December also saw the revival of the biannual spraying of the Chicago House grounds against insects, something that had not been done for a decade, and the lack of which had resulted in the decimation of the flower beds, particularly our famous rosebushes. Fifty-three new rosebushes were brought in to restore the old rose beds; by March they were gushing with blossoms. The remnants of the old bushes are perking up as well, blossoming like crazy and showing excellent signs of recovery.

Tourism was definitely "up" this year, and Chicago House saw many friends, colleagues, and guests stop by. In October Susan Allen from the Metropolitan Museum of Art stayed several nights with us after her season at Dashur, and reminisced about her earlier years here with husband and former Chicago House epigrapher James Allen. William Harms, Senior News Writer with the University of Chicago and good friend to the Oriental Institute, stopped by over Halloween to see our work, the result of which was an excellent article on our Medinet Habu work published in the February 1999 issue of the *University of Chicago Magazine*. Oriental Institute Visiting Committee member Dr. Marjorie Fisher paid us several pleasant visits during the season, including Halloween, while former Chicago House epigrapher and administrator Peter Piccione and his Theban Tomb Project crew (including wife Myrna and former Chicago House photographer Danny Lanka) came by often while working on the West Bank. Friends of Chicago House tour veteran Tom Granger came by to do research on his Masters thesis for Yale University, and Dick Cook from the Virginia Museum of Art in Richmond came by to prepare for the Hildesheim show of Egyptian art, scheduled for the Richmond Museum this summer. Former Epigraphic Survey Director Chuck Van Siclen very kindly presented Chicago House with a copy of *Ancient Egypt, the Aegean, and the Near East: Studies in Honour of Martha Rhoads Bell*, Volume 1, edited by J. Phillips (San Antonio: Van Siclen Books, 1998), which he has recently published. On 31 October, Chicago House hosted its annual Halloween costume party for all of our friends and expeditions in the area, always a popular event.

The beginning of November saw the return to Chicago House of the Demotic Dictionary's Steve Vinson and colleague Alejandro Botta for a visit, followed soon after by the Metropolitan Museum of Art's Dorothea Arnold, Malcolm Wiener, and former staff member Jim Allen, whose wife Susan had visited earlier. Colleague and roving reporter for the Egypt Exploration Society *Egyptian Archaeology Bulletin* Lisa Giddy stayed with us a week in the middle of the month. 17 November marked the first year anniversary of the Hatshepsut massacre, and wreaths were laid at Deir el-Bahri very quietly that morning by the Japanese and Swiss Ambassadors. That same day United States Consul Roger Pierce and Embassy Security Deputy Director

Scott Gallo dropped by Chicago House for tea. They were on an inspection tour of the major archaeological sites in the Nile Valley to check on security arrangements and reported that they were very pleased with what they saw.

Thanksgiving Day dinner guests included Geoffrey Martin, Peter Lacovara, and Nick Reeves (in town starting up their exciting new Valley of the Kings project); Nigel Strudwick and his Theban Tomb crew; the Antiquities Development Project's Bojana Mojsov who was working in the tomb of Sety I; United States Embassy Public Affairs Officer Bill and Cary Cavness and their two daughters; old friends David and Diana Lipsey; and American Research Center in Egypt Cairo Director Mark Easton. On the last day of the month we had a site visit from the Director of the Egyptian Antiquities Project Chip Vincent, Assistant Director Jarek Dobrolowski, and Antiquities Development Project Director Michael Jones, plus thirty members of the United Nations Donor Agency Group, who came to see the documentation and conservation work at the small Amun temple.

In December former Chicago House staff member John Darnell joined wife Debbie for a month of intensive surveying, exploration, and documentation of the western desert road, for which Debbie's time, one of our Land Rovers, and the use of our facility were donated by Chicago House in support of that important project. Barbara Adams and her University College London crew stopped by Chicago House after a month at Hierakonpolis on their way back to England for the holidays. In late December Colin Hope stayed with us for a few days on his way to Dakhla Oasis and assisted the Jacquets in the analysis of pottery found in their north Karnak excavations. The holiday season was filled with friends and holiday cheer. Dinner guests included Boyo Ockinga's Australian team working on late Ramesside tombs across the river; Nigel and Helen Strudwick and their Theban tomb team; Ted and Lyla Brock, working on the re-assembly of stone sarcophagi in the tomb of Ramesses VI; and Rosalind and Jac Janssen. Stopping by in mid-month were old friends Eleanor

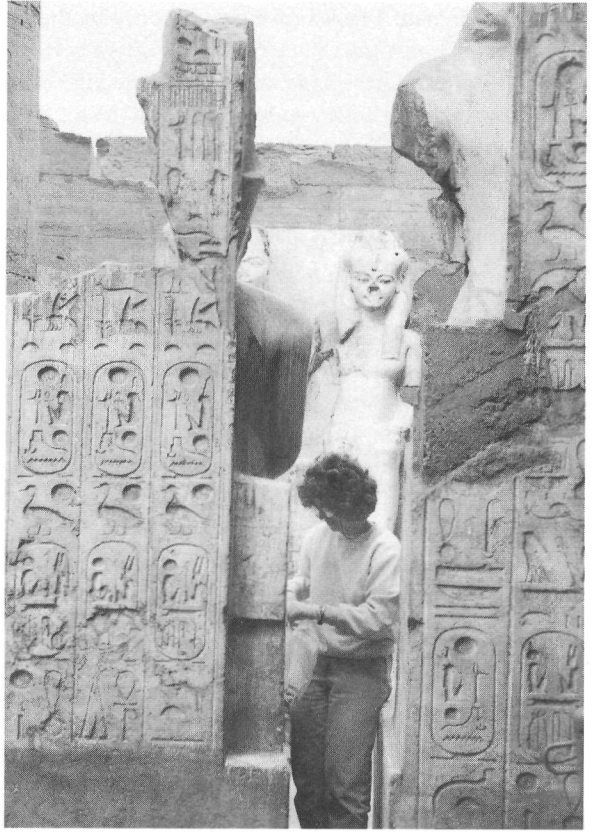

Figure 9. Conservator Dr. Ellen Pearlstein cleaning small diad of Amun and Mut, Colonnade Hall, Luxor Temple. Photograph by Sue Lezon

ARCHAEOLOGY

and Richard Johnson, followed shortly by their newlywed daughter Betsy and husband Jason Crook. Our New Year's Eve celebration was small but merry, the only guests being Ros and Jac Janssen. The kitchen crew outdid themselves with a five-course dinner followed by dancing in the tea room to some of Breasted's old 78 rpm records, a fitting way to ring in the new year.

1 January also saw the continued steady influx of other friends and colleagues into Luxor. Bruce Williams stopped by to borrow our Nubian Expedition theodolite for his work at Hierakonpolis with the Penn State team. Former Epigraphic Survey Director Chuck Van Siclen and former Oriental Institute Museum Curator Tom Logan arrived to resume their excavations between the Eighth and Ninth Pylons at Karnak, and Betsy Bryan arrived with twelve students to conduct her final season's documentation work at the tomb of Suemniwet on the West Bank. A few days later American Research Center in Egypt Treasurer Charlie Herzer and his wife Adrienne stopped by for a visit and dinner, friends Renee Friedman and Will Schenck stopped briefly on their way down to Hierakonpolis to continue their work on the site, Berkeley's Candy Keller came by for a library tour with a large group from southern California, and former artist (now architect) Jay Heidel arrived for a two-week visit. On 11 January the United States Ambassador to Egypt Daniel C. Kurtzer and his family arrived in Luxor to visit and see our work. As the Ambassador was observing Ramadan fasting, we gave them an *iftar* dinner at sundown on 12 January, which was quite festive. I acted as their guide during their two days in Luxor, showing them our work at Medinet Habu and Luxor Temple as well as other sites on both sides of the river and took special care to point out the signs of accelerating decay everywhere. Finally, at the end of the month former Chicago House staff member Carol Meyer returned to resume her work at Bir Umm Fawakhir in the Wadi Hammamat with logistical support and food supplies contributed by Chicago House.

On Wednesday 27 January, Ambassador and Mrs. Kurtzer graciously hosted a reception at the United States Embassy residence commemorating Chicago House's 75th anniversary. The event was timed to coincide with the arrival in Cairo of the University of Chicago Women's Board tour, led by the Oriental Institute Museum Archivist John Larson and Director of Development Tim Cashion, and allowed us to inaugurate the celebrations in style with folks from back home. Other guests included Visiting Committee member Dr. Marjorie M. Fisher, USAID, American Research Center in Egypt, and Egyptian Antiquities Project directors, various Supreme Council of Antiquities and Embassy officials, corporate heads, and friends. Senior Epigrapher Ted Castle, Artist Bernice Williams, and Epigrapher Hratch Papazian assisted Carlotta and me in representing Chicago House. Carlotta and I visited various Cairo corporations in our ongoing fund-raising efforts, and while there I made the last payment on our renovation loan, another major milestone (and a terrific way to begin the new year!). We continued the 75th anniversary celebrations in Luxor by hosting the Women's Board tour at a reception, library talk, and dinner at Chicago House, where our guests were able to mingle and talk with the entire staff. That day I gave them a tour of Luxor Temple and the blockyard, while the next day Ted Castle gave them a tour of the small Amun temple at Medinet Habu and a closer look at our work.

On 8 February Chicago House hosted a reception and library talk for the American Research Center in Egypt conservation school led by Brooklyn Museum conservator Ellen Pearlstein (two weeks in Cairo, two weeks in Luxor). The sixteen Egyptian conservators were shown the fragment conservation work at the Luxor Temple blockyard by conservator Hiroko Kariya, the Colonnade Hall indurated-limestone statue cleaning and restoration by Ellen herself, and the Medinet Habu small Amun temple relief cleaning by conservator Lotfi Hassan. On 18 February Chicago House hosted a reception and talk for the American Research Center in Egypt New York tour; Ted gave the group a site tour of Medinet Habu featuring the work of the Epigraphic Survey, and I gave them a tour of Luxor Temple and the work of the Epigraphic Survey there. In mid-February USAID

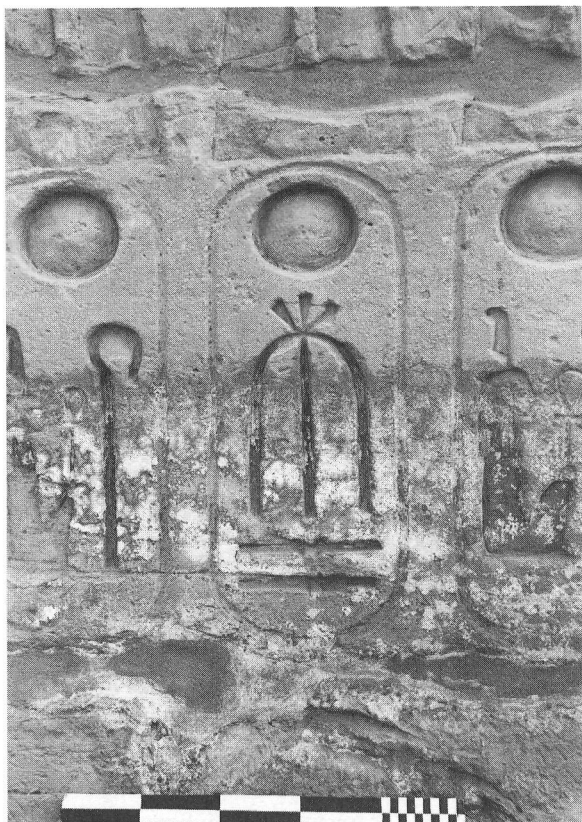

Figure 10. Disintegrating wall reliefs (cartouches of Ramesses IV), east wall Colonnade Hall, Luxor Temple. Photograph by Sue Lezon

Egypt Financial Director Shirley Hunter came down for a review of Chicago House's financial management system, and also to run in the annual Luxor Marathon with 15 other USAID members (Chicago House assisted with water along the West Bank race course). She had an excellent run, and I am pleased to say that we had an excellent review as well.

March was particularly noteworthy for friends who stopped by, although to our great disappointment beloved friend Barbara Mertz could not make it out this year (she swears she will make up for it next season, and we intend to hold her to her promise). Chicago House hosted a reception and library talk for the Washington, DC chapter of ARCE, guided by Ph.D. candidate Nicole Hansen. Mark Lehner and his family were in Luxor during the first two weeks of the month shooting a second obelisk documentary, and were able to join us for a meal or two. Jason Ur spent a good week with us working on our Photographic Archives database. Former Chicago House epigrapher Lorelei Corcoran stopped by on a tour, as well as friend Barbara Porter from the Metropolitan Museum of Art. Kaylin Goldstein (who very capably oversaw the Epigraphic Survey's Oriental Institute office for a couple of winters while we were away) and her parents Iris and Paul Goldstein (Oriental Institute

ARCHAEOLOGY

Visiting Committee) spent a very pleasant afternoon with us seeing our facility and the work at hand.

A most illustrious guest in March was the First Lady of the United States, Hillary Rodham Clinton, who visited Egypt with daughter Chelsea, and spent a total of two full days in Luxor. Preparations for this trip began in February, and continued all through March, as “pre-advance” and “advance” teams of White House and United States Embassy staff descended on us for a seemingly endless round of itinerary planning and site walk-throughs. Right up to the day she arrived the itinerary was in flux, but after all the hair-raising preparations, the visit itself was wonderfully pleasant. The First Lady and Chelsea arrived midday on Tuesday 23 March, and I was among the official “greeters” at the airport, along with the Governor of Luxor General Selmy Selim, the American Ambassador to Egypt Daniel Kurtzer, and the head of the Supreme Council of Antiquities, Dr. Gaballa Ali Gaballa. Dr. Gaballa and I were her official guides during her Luxor stay, and that first afternoon we squired her, the United States Ambassador, the Egyptian Minister of the Environment Dr. Nadia Makram Ebeid, and the head of USAID Egypt Richard Brown through the Luxor Museum of Art and Luxor Temple. Debbie Darnell led the White House staff on a separate tour behind us, while our friend the General Director for the West Bank, Sabry Abdel Aziz, led the press corps.

Mrs. Clinton was clearly impressed with the extent, and scale, of Luxor’s ancient remains. An avid preservationist herself, she was distressed by the signs of accelerating decay that are now visible everywhere, particularly in the Colonnade Hall. While at Luxor Temple I was able to point out the all-too-visible problems caused by Egypt’s wetter climate, the high groundwater, and the resultant migration of salts trapped in the stone, all causing the bases of massive walls and columns to disintegrate. After visiting the Luxor Temple sanctuary, we paused beside the Epigraphic Survey blockyard with its thousands of decorated stone fragments, where I talked about our Egyptian Antiquities Project/USAID funded fragment documentation and conservation projects.

That evening I was invited by the First Lady to join her, Dr. Gaballa, Ambassador and Mrs. Kurtzer, several USAID officials, and the assembled White House Press Corps for an al fresco dinner and round-table discussion about Luxor, its heritage, and its preservation problems. Dr. Gaballa opened with a talk about the significance of ancient Luxor, after which I spoke about the documentation work of the Oriental Institute at Chicago House, our history, present programs, and future plans. This led to an open discussion of the conservation problems facing Luxor and all of Egypt, and what steps have been taken to alleviate some of those problems elsewhere, such as the USAID Old Cairo drainage project, which by lowering the water table has slowed down the deterioration process. It was such a stimulating discussion that the party only grudgingly broke up at midnight!

The next day we took the First Lady and Chelsea to the Valley of the Kings where Egyptian Antiquities Project Director Chip Vincent, Antiquities Development Project Director Michael Jones, Dr. Gaballa, and I showed them the tomb of Sety I and discussed its history and conservation problems. Then Dr. Gaballa and I took them to Tutankhamun’s tomb, followed by the mortuary temple of Hatshepsut, and Nefertari’s tomb in the Valley of the Queens. This in a motorcade 40 cars long,



Figure 11. Volunteer Mary Grimshaw hard at work in the Chicago House computer room, March 1999. Photograph by Sue Lezon

mind you. At about 1:30 the entire motorcade arrived at Chicago House, where we hosted a “private,” sit-down buffet lunch for the First Lady, Chelsea, and forty assembled guests: the entire Chicago House staff, Dr. Gaballa, the Governor of Luxor, the Kurtzers, the Minister of the Environment, USAID officials, Kent and Susan Weeks, American Research Center in Egypt Director Mark Easton, Chip Vincent, Michael Jones, and Sabry Abdel Aziz. Credit must be given to the entire Chicago House staff for making the place shine, and the luncheon table glorious; everyone pitched in. Our kitchen staff, headed by chief cook Tayib Abdel Aziz Mohamed, truly outdid themselves, and Mrs. Clinton endeared herself to them forever by having her photograph taken with them afterward in the courtyard. She said in a short speech at lunch that the Luxor trip was one revelation after another, chief among which was the University of Chicago’s efforts in Luxor. She told us that she was tremendously moved by our dedication, enthusiasm, and passion for this preservation work and was extremely proud that Americans were at the forefront of such work. After a group photograph of the entire luncheon party, Carlotta and I led the First Lady, her entourage, and the press into the library for a half-hour briefing of our documentation work, projects, and goals, which was very well received (fig. 12). I owe a tremendous debt to Carlotta for returning to assist with this event; we could not have done it without her. After signing the guest book, picking up a “Chicago House: 75 Years” button, and accepting a *Lost Egypt* print as a memento of her visit from Carlotta and Sue Lezon (and Chicago House t-shirts), we departed with Mrs. Clinton and entourage for Karnak up the street. There we had a very pleasant late-afternoon walk through the temple.

But that was not the end of the day. Later that evening at Luxor Temple, the Minister of Culture Farouk Hosny hosted a lavish banquet for the First Lady in the



Figure 12. *The First Lady's visit to Chicago House; in library, receiving Lost Egypt print from Carlotta Maher. From left to right, foreground: Carlotta Maher, Ray Johnson, Mrs. Clinton, Chelsea Clinton. Background: Supreme Council of Antiquities Director General Dr. Gaballa Ali Gaballa, Chicago House Staff Photographer Yarko Kobylecky. Photograph by Sue Lezon*

first court of Ramesses II. While a string quartet played in the southwest corner, and brilliantly-lit 35-foot statues of Ramesses II gazed down on the assembled Egyptologists and dignitaries, Mrs. Clinton, Chelsea, and the Minister of Culture greeted each guest in a receiving line on the east side. Ten tables were set up along the west side of the court, and I had the pleasure of being seated with the First Lady, the Egyptian Ministers of Culture, Health, and the Environment, Mark Easton, Ambassador Kurtzer, Dr. Gaballa, and the Governor of Luxor. The next day, while her mother was giving speeches at the El-Karnak Clinic and a local school, I escorted Chelsea and White House Social Director Capricia Marshall to the West Bank for a tour of Medinet Habu, where Ted Castle, Margaret De Jong, and Lotfi Hassan showed them our epigraphic and conservation work. We then took in some private tombs, after which we drove back to the Luxor airport for their departure to Tunisia. Later that afternoon I returned to Medinet Habu with new USAID Director Richard Brown for another important site visit before he returned to Cairo.

All in all it was a very stimulating visit, and the good will it generated was far-reaching and across the board. I truly believe that it was time well spent, and that we were a credit to the Oriental Institute and the University of Chicago.

Finally, our 75th anniversary was celebrated with our friends and colleagues back home in Chicago on 23 April, when I was honored to give the keynote address at the American Research Center in Egypt Fiftieth Annual Meeting, hosted by the Oriental Institute, entitled: "The Epigraphic Survey on the Occasion of its Seventy-



Figure 13. Chicago House professional staff 1997/98. Photograph by Yarko Kobylecky

fifth Anniversary.” Most recently, on 20 July, I spoke on the same topic to the University of Chicago Women’s Board. There is much to be proud of in this anniversary year, but as Breasted would remind us, there is still much to do. Chicago House must adapt to the rapidly changing conditions in Egypt by expanding its documentation and conservation programs in order to preserve what little is left, a goal well worth striving for. Here’s to the challenge, the new millennium, and the next 75 years!

The professional staff this season (fig. 13), besides the Field Director, consisted of Ted Castle as Senior Epigrapher; Deborah Darnell as Epigrapher and Librarian; Hratch Papazian and J. Brett McClain as Epigraphers; Susan Osgood, Tina Di Cerbo, Margaret De Jong, Bernice Williams, and Carol Abraczinskas as Artists; Yarko Kobylecky and Susan Lezon as Photographers; Ahmed Harfoush as Administrator; Moataz Abo Shadi as Finance Director; Marlin Nassim as Accountant; Jill Carlotta Maher as Assistant to the Director for Development; Elinor Smith, Nan Ray, and Mary Grimshaw as Assistants for the Photographic Archives and Library; and Saleh Shahat Suleiman as Chief Engineer. Dr. Lotfi Hassan, John Stewart, Hiroko Kariya, and Ellen Pearlstein worked with us as stone conservators, and Dany Roy as stonecutter. Special thanks go to Dr. Henri Riad, Egyptologist in residence for the season, and to Drs. Helen and Jean Jacquet, who all shared their expertise generously. Numerous friends and members of the Supreme Council of Antiquities generously assisted us during our work this season, and to them we owe, as always,

ARCHAEOLOGY

a special debt of thanks: Professor Dr. G. A. Gaballa, Director General; Dr. Mohamed el-Saghir, General Director of Pharaonic Monuments in the Nile Valley; Dr. Mohamed Nasr, General Director of Antiquities for Upper Egypt; Dr. Sabry Abdel Aziz, General Director for the West Bank of Luxor; and Mme Nawal, Chief Inspector of Luxor Temple. Warmest thanks and best wishes to all.

As the old millennium ends and the new millennium fast approaches, I would like to express my heartfelt thanks to the many friends of Chicago House whose support has allowed our work to continue without interruption into the 21st century; we truly couldn't do it without you. Special thanks must go to the American Ambassador to Egypt, the Honorable Daniel Charles Kurtzer, and Sheila Kurtzer; Vincent Battle, Deputy Chief of Mission of the United States Embassy in Cairo; William Cavness, Janet Wilgus, and Haynes Mahoney of the United States Embassy; Dick Brown, John Westley, Justin Doyle, Shirley Hunter, and Jean Durette of the United States Agency for International Development; Exa Snow of Coopers and Lybrand, Cairo; David and Carlotta Maher; David and Nan Ray; Mark Rudkin; Dr. Barbara Mertz; Daniel Lindley and Lucia Woods Lindley; Dr. Marjorie M. Fisher; Tom and Linda Heagy; Donald Oster; William Kelly Simpson; Kelly and Di Grodzins; Dr. Ben Harer; Anita and Solon Stone; Roxie Walker; Louis Byron, Jr.; Terry Walz, Mark Easton, Ray Salamanca, Mary Sadek, and Amira Khattab of the American Research Center in Egypt; Chip Vincent, Jarek Dobrolowski, and Cynthia Scharzter of the Egyptian Antiquities Project; Michael Jones of the Antiquities Development Project; and all of our friends on the Oriental Institute "mother ship." I must also express our gratitude to the Amoco Foundation, the Getty Grant Program of the J. Paul Getty Trust, Coca-Cola, Bechtel, Xerox, and LaSalle Banks for their invaluable support. Thank you all.

As always, members of the Oriental Institute and other friends of Chicago House are welcome to stop by to see us, and we suggest that you write or call in advance to schedule a meeting that is convenient to all. Chicago House is open from 15 October until 15 April, and closed Saturday afternoons and Sundays. Our address in Egypt: Chicago House, Corniche el-Nil, Luxor, Egypt. The telephone number is (from the United States) 011-20-95-37-2525; fax 011-20-95-38-1620.

The Epigraphic Survey home page is at:

<http://www-oi.uchicago.edu/OI/PROJ/EPI/Epigraphic.html>

GIZA

Mark Lehner

Our most recent excavation season took place from late January through April 1998. From 19 February until 15 April 1999 Mark Lehner, John Nolan, Justine Way, Cordula Werschkun, Teri Tucker, and Noha Abu Lila carried out a study season on

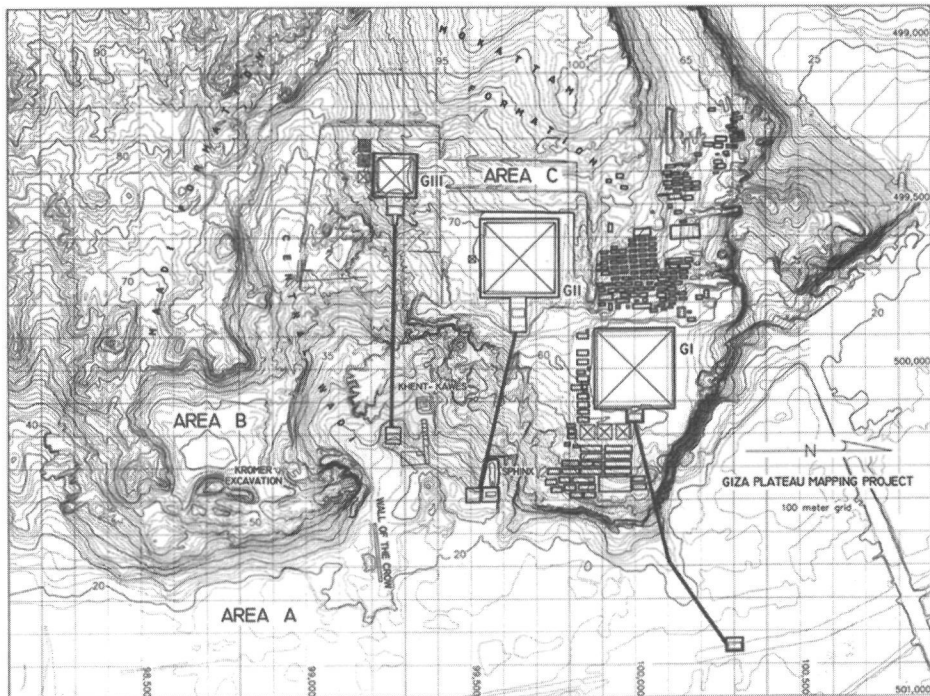

Figure 1. Map of Giza with Area A on low desert southeast (lower left) of the pyramids

ceramics, sealings, lithics, and bone in the project storeroom in the Western Cemetery. Here I report results of the 1998 excavations.

Summary of the Previous Seasons 1995–1997

Since 1988 we have been excavating at the foot of the Giza Pyramids Plateau about 300 m south of the Great Sphinx. Our site is a 13 ha tract of low desert stretching 450 m south of a large stone wall called Heit el-Ghurob, “Wall of the Crow,” and 250 m between the urban zone of Kafr Gebel and the high desert (fig. 1). We refer to this site as Area A (fig. 2). In 1991 we discovered two bakeries with intact dough-mixing vats, hearths, and bread pots. The bakeries were attached on the south side of a thick mudbrick wall that turned a corner at the bakeries and extended beyond the limit of our excavations to the north and west. In 1995 we excavated a series of squares inside the corner enclosed by the wall and here we found low troughs and benches. We found fish remains embedded in the floor nearby and fish bone in the soil that filled the troughs. In 1997 we excavated a series of squares farther west and north in order to trace the extent of the wall. I hypothesized that we may be finding an outer enclosure, given over to production activities, around a central institution or household.

We ascertained that the wall extends as far as 65 m to the west (fig. 8a). Other thick mudbrick walls extend to the north and the south. As far as we could tell from our 5 × 5 m excavations, the walls running north from our main wall suggested (modular?) series of chambers in which we found evidence for meat processing and

ARCHAEOLOGY

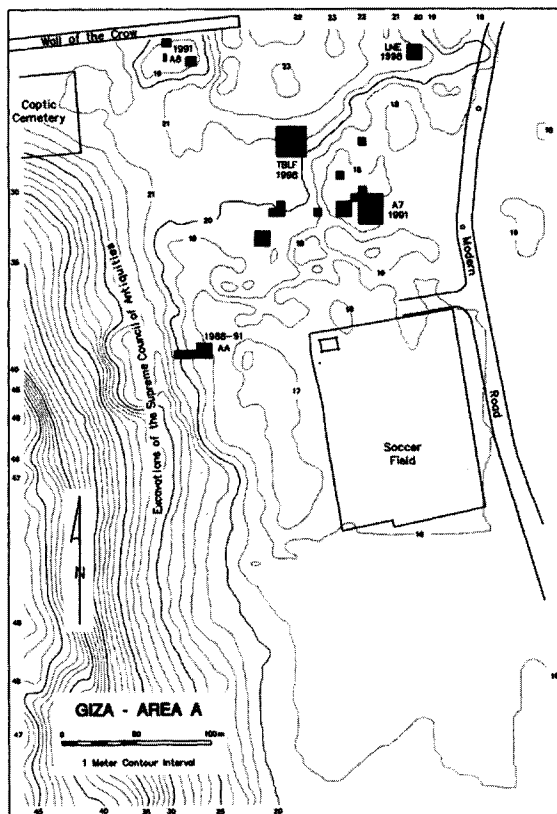

Figure 2. Map of Area A with squares excavated 1998/99

and northwest with our excavations, in the direction of the large stone wall, Heit el-Ghurob. Before we could excavate we needed to move an enormous overburden of modern sand and other deposits nearly 4 m deep including sand dumped from Selim Hassan's 1936 excavations north and east of the Sphinx. We are grateful to Engineer Abd al-Hamid and the Giza Pyramids Inspectorate for helping us move this modern material so that we could eventually survey a broad square, 20 × 20 m, consisting of 16 regular 5 × 5 m squares, 35 to 55 m north of the 1997 squares in the D-row (fig. 2). We named this operation "the big leap forward" (TBLF). While we were moving the modern overburden in TBLF, we began smaller excavations to the south to investigate features that aroused our interest in the 1997 season; these are described first.

Square A6-7-ZZ6-7

Our first excavation area was 10 m south, and 5 to 10 m west, of squares D8-9 (fig. 2). Here the people who dig sand for cleaning the nearby riding stables had already exposed a series of stony small mounds in a low area with little modern overburden. Fiona Baker supervised a 10 × 10 m excavation square. The mounds that piqued our interest were the result of collapsed stone rubble walls forming small chambers resembling workers or guardhouses found at other sites. The rooms were filled with

other food production, copper work, and pigment grinding. Fifty meters to the north of the 1991 bakeries, in a 5 × 5 m square (M-N20), we uncovered part of an extensive mudbrick structure with small and narrow rooms oriented north-south and two stone pediments. Late in the 1997 season, John Nolan excavated square I17, to the northwest, "inside" the north and west alignments (fig. 8a). John uncovered a simple structure divided into two rooms that, in simplified form, resembles workers divided court houses as found in the New Kingdom at el-Amarna and Deir el-Medineh.

1998 Objectives

In 1998 we wanted to test the hypothesis that these production facilities may lie in an enclosure around a large household or core institution, perhaps even a royal residence by moving farther north

ashy soil, large quantities of pottery sherds, and dolerite hammer stones. The east side of this small complex, badly eroded, included a courtyard with a south-eastern entrance flanked by two crude limestone pediments. As we have seen elsewhere on our site, the stone walls were a partial rebuilding of the main phase of mudbrick walls that had fallen into ruin.

Squares D9 and E9

We expanded the area of Squares D8–9 by excavating square E9 to the north (fig. 8a). Here three walls run north from the main east-west wall excavated in 1997. One of these walls extends through approximate center of combined squares D9–E9. On one side of this wall, along the east side of the excavation squares, the room was filled with marl clay floor levels separated by ashy layers that contained pottery sherds, bone, and charcoal. Later in antiquity someone dug a trench through

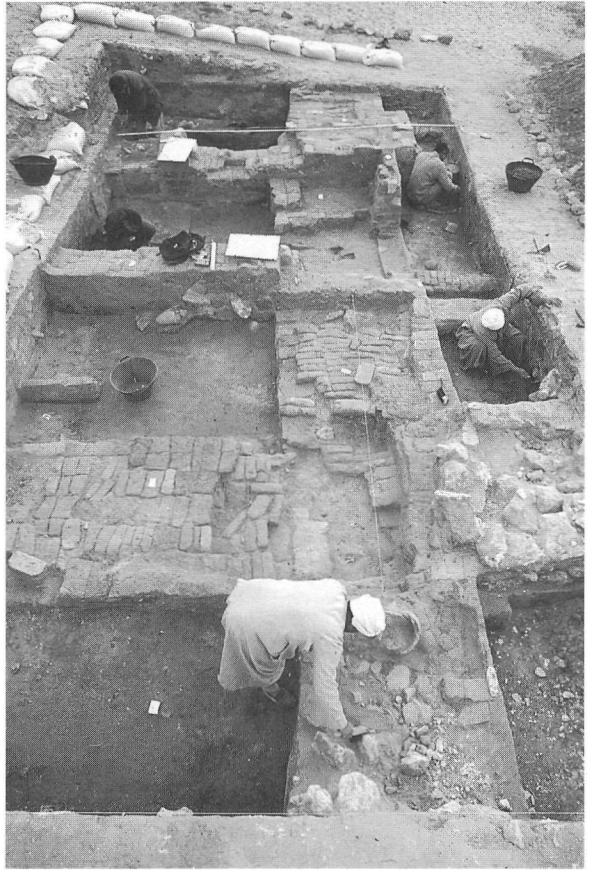

Figure 3. Squares D8 and D9 with main east-west wall traced in 1997, looking east

the floor layers along the north-running wall to take out bricks for reuse elsewhere. In one of the marl-ash floors, John Nolan, who supervised work in Squares D9 and E9, found a series of small round egg-carton depressions similar to the bread-baking pits that we found in 1991. A half bread mold was still in place in one of the sockets.

The layout on the other side of the north-south wall resembled a simplified rectangular house plan with a central wing wall dividing it into two main chambers. Like the smaller structure that John Nolan cleared in square I17 in 1997, this plan resembles a simple version of New Kingdom workmen's houses such as those at Deir el-Medineh. In 1997 we found several dolerite hammer stones on an ashy floor in the southern of two main chambers and a cooking installation built into the southern wall. The northern chamber had hearths in the southwest and northwest corners.

The rooms were not filled up with superimposed floors like those on the other side of the north-south wall. We did find, however, evidence of an earlier phase with a different arrangement of walls. Under a long rectangular patch of black ash that ran along the east wall and through the doorway between the two rooms we found another set of egg-carton shaped holes or baking sockets. This baking pit was



Figure 4. John Nolan in square E9 examines traces of the bin and granary(?) in the northern room of the “house”

used before the eastern north-south wall was built; the wall’s foundation trench cut through the baking sockets. Traces in the earlier floor revealed that the wall separating the two rooms of the “house” had first been the south wall of a square bin (fig. 4). Only a row of foundation bricks and a plaster line remain of the east wall of the bin that was taken down when the larger east wall of the “house” had been built. The south wall of the bin was saved to divide the “house” into two rooms. The earlier floor inside the bin had been carefully paved with marl clay, except for a round mudbrick feature plastered inside with alluvial mud — probably the remains of a small granary. The purpose of the bin was probably to hold the excess and spilt grain on the clean marl floor.

Square D17x: Copper Working

At the end of the 1997 season, in a narrow space between the ancient walls and the northwest corner of square D17, Justine Way found a hearth that had scorched the walls to a bright orange. Complete and fragmentary bread molds lay nearby. The heavy fraction from the flotation of the soil yielded many fragments of copper slag. To investigate further this evidence of metallurgy Justine expanded in a diagonal 5 m square, D17x (figs. 2, 8a). Here in a chamber measuring 4.20 m north-south and 1.90 m east-west there was much evidence of copper work. Again there were several floor levels. Over time a cross-wall divided the chamber in two similar sized chambers (fig. 5). In each chamber a large bread mold had been plastered in place against the walls, one at the center of the south wall, another in the northeast corner. These had apparently been used as crucibles or for heating copper implements. Each was held in place by a collar of large sherds and mud that had been fired like brick from the heat. The one in the northeast corner was set at an angle, tilted toward the user (fig. 6a). The one at the south wall, less complete, was set vertically. We found bread mold sherds that had been heated to the point where the ceramic was vitrified, embedded with small bits of corroded green copper. Near the bread mold/crucible in the northeast corner, Justine found

three jars upright in the floor. The ashy contents included small bits of copper slag and a flint knife. Justine found more copper slag in the floor deposits as well a thin copper rod and a copper fishhook. Along the east wall of the chamber in the earliest floor there was a deep trench filled with concentrated black ash.

The old idea that bread molds were crucibles for molten copper was discarded when their function in baking was ascertained. The finds in D17x reveal that the bread mold could be used for copper work as well. The hearths with bread molds as centerpieces do not resemble the crucibles shown in the Old Kingdom tomb scenes, which have a kind of double saddle shape. But in the Tomb of Niankh-khnum and Khnum-hotep at Saqqara, next to a scene of men using blow pipes at a typical crucible, is a scene of a man holding a large bread mold at an angle while another man uses a blow pipe to heat the interior (fig. 6b). The installations in D17x were probably not for smelting copper from raw ore, which would have been done closer to the source in the mines. Rather here small implements were made or tools were hardened by tempering or annealing, perhaps by heating them in the bread mold hearth and then quickly cooling them for pounding by dunking them into water in the large jars that we found implanted nearby in the floor.

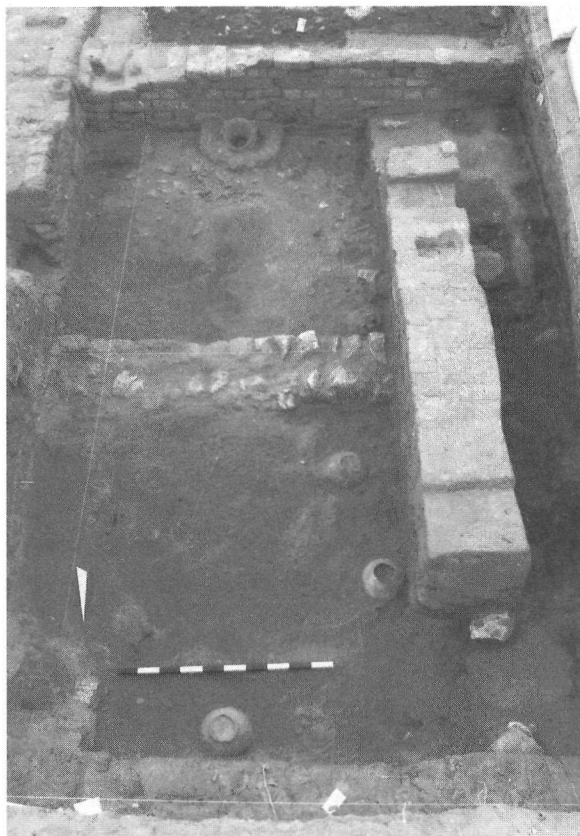

Figure 5. Copper-working chamber in square D17x, looking south

“The Big Leap Forward” (TBLF)

Our 20 × 20 m excavation square, TBLF, comprised sixteen 5 × 5 m squares (figs. 2, 7). Mr. Mohsen Es-Sayyad supervised much of the work in Square TBLF, and especially the excavation in squares L11 and M10. Heba Ragab, Carl Andrews, and Mark Lehner also supervised excavation squares.

We conducted extensive excavation in seven of the 5 × 5 m squares. By scraping about 10 cm of the compact mud surface off the top in all 16 squares we revealed the outlines of a repeating, modular series of long galleries, separated by massive walls about 1.5 m thick, and spaced every 10 cubits (5.25 m; fig. 8b). A



a

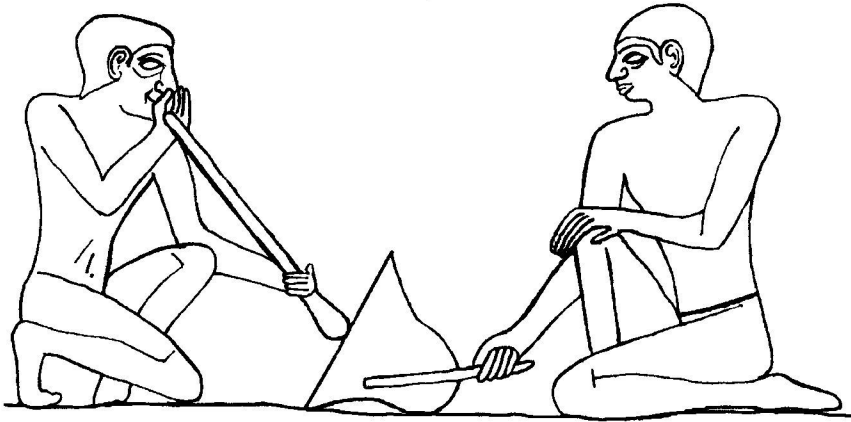

b

Figure 6. (a) Bread mold hearth and jar embedded nearby in floor in northeast corner of chamber in square D17x and (b) Scene of men working copper from Fifth Dynasty Tomb of Niankh-khnum and Khnum-hotep at Saqqara

common southern wall defines a street, with several layers of plastering and periods of repair, that separates the galleries from the set of buildings we are finding about 35 m to the south in the D-file of squares (fig. 8a).

Each gallery had a doorway onto the street. By the time the galleries were abandoned, the doorways were filled with large bread molds and bread mold sherds and stones. Inside the doorways, the rooms at the southern end of the two western galleries contained thick deposits of concentrated black ash, large numbers of bread mold sherds, and several floor levels pitted by trenches and sockets used as baking pits. Walls subdivided the central part of the two western galleries into small rooms that



Figure 7. General view of 20 × 20 m excavation square, TBLF, looking northwest

were paved with marl plaster and kept relatively clean. These could have been for habitation, supervision of the pyro-industry in the back southern rooms, or storage and processing for craft and production. One of the central chambers contained two small rectangular bins built against the thick eastern wall of the gallery (fig. 8b). The northern bin was filled with several floor levels, the lowest of which was stained with yellow, orange, and red pigment, probably from hematite.

The north end of the galleries were open courts, divided nearly in equal halves by two rectangular pediments in squares 09 and N9, and by thin walls in 011 and 012. In the archaeological record, in models, and in tomb scenes ancient Egyptian workshops have closed areas in the back for storage and interior work, and open areas in front where natural lighting allows craftwork to take place.

“Leap to the Northeast” (LNE)

“Leap to the northeast” (LNE) was our exploratory excavation 65 to 70 m east and 65 m north of TBLF; 110 m north and 20 m east of the bakeries that we found in 1991; and 115 m east-southeast of the end of the large stone wall called Heit el-Ghurob (fig. 2).

We excavated the northwestern and southeastern quadrants of a 10 × 10 m square (fig. 9). In both squares, just under the clean sand, we exposed a layer of dense black mud about 10 to 20 cm thick. The surface is 16.16 m above sea level, about half a meter lower than the top of the Old Kingdom remains in TBLF. It contained no artifacts and very few pottery sherds. As we dug deeper, the mud became sandier for a total thickness of 34–40 cm, thinning slightly to the west. The few sherds included ribbed fragments of Graeco-Roman amphorae. In the northwestern square, a thin layer of clean sand separated the mud from patches of compact brown

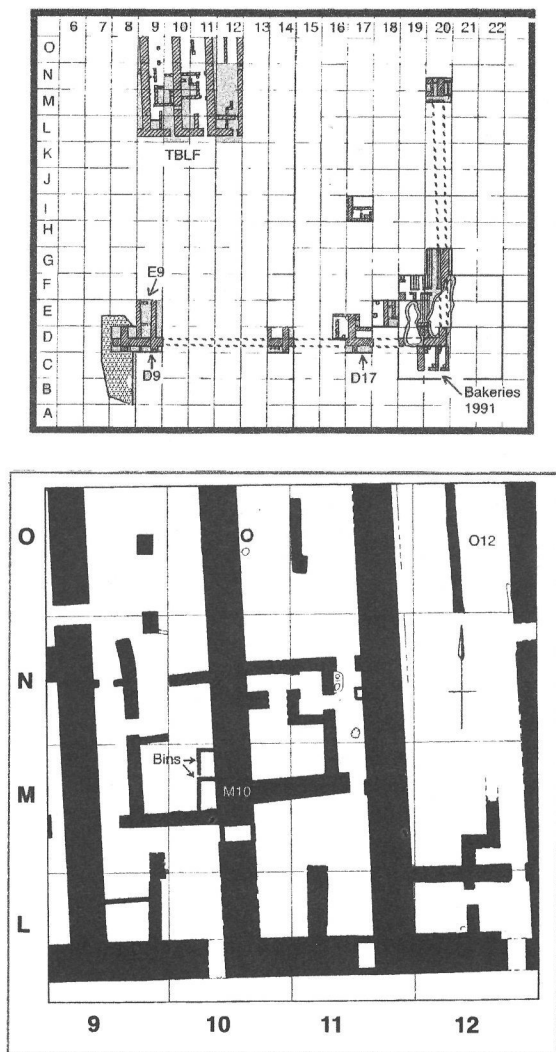

Figure 8. (a) Excavation grid and squares worked from 1995 to 1998, with sketches of major walls; and (b) Map of long galleries in 20 × 20 m excavation square, TBLF

Valley Temple, found in the AMBRIC sewage trenches; and the Zaghoul Street wall of limestone and basalt, found during construction work in 1993. The level of these features is about 15 m above sea level.

Summary

In six seasons we have revealed rectilinear architecture, oriented to the cardinal directions, for systematic production, extending from near the Heit el-Ghurob (where we found a badly eroded bakery in 1991), as far as 225 m to the south, where we excavated squares AA1 through AA10 (1988–91), and for nearly 200 m east-west.

clayey sand at an elevation of 15.66 m above sea level, a meter lower than the top of the Old Kingdom layer in TBLF (about 16.64). The patches were surrounded by clean gravelly sand with many small rounded pebbles. In two probes the gravelly sand continued to a depth 1.11 m, although it became coarser with more dark, rounded pebbles.

The patches of Old Kingdom soil represent a trodden surface outside the major occupied area. The upper layers of dark concentrated mud must be alluvium deposited by the annual Nile floods. We know from the borings and trenches of the AMBRIC Waste Water Project in the late 1980s that the annual flood waters deposited 2.5 to 3.0 m of alluvium in the floodplain alongside the Giza Plateau since the Old Kingdom. Eventually the floodplain was high enough so that the silt-laden waters reached far enough west to deposit mud over the sloping desert surface along the limits of Area A. Other major markers of the Fourth Dynasty level that must have remained just above the flood are the bottom of the colossal stone wall, Heit el-Ghurob, which we found in a trench (A8a) during our 1991 season; the basalt pavement blocks from the Khufu

The evidence of the mud seal impressions, as well as our preliminary assessments of the pottery, indicates that the main phase was mid to late Fourth Dynasty.

Soon after the reign of Menkaure most of this complex fell into disuse and its walls were robbed for bricks to be used elsewhere. Some people remained and built stone rubble additions within the earlier walls. Kings Shepseskaf and Userkaf built their tombs at Saqqara where the royal house had probably moved after three generations at Giza. After the entire complex was purposefully leveled and buried, the settlement changed from a major focus of the royal house to the village that George Reisner found in front of the Menkaure Valley Temple in 1904.

We still understand little about the overall social context and organization of our site. What we found in Square TBLF does not confirm the existence of a core residence, or palace in Area A, although there is little doubt that all the facilities we are finding are an extension of the royal house. Some of the structures we found could be simple houses for workers, but we are not sure if the site includes a tightly organized town along the lines of the Khent-kawes pyramid town at Giza, or the Twelfth Dynasty pyramid town of Illahun. The house-like enclosures are closely associated with evidence of production, but it remains unclear whether or not production is separate from household. The TBLF galleries may reflect the systemic production of an economy of scale. Richard Redding, our faunalist, points to the large quantities of young, prime, cattle bone. People must have been eating this meat on, or near, our dig site and presumably living in the vicinity. Bread baking is evidenced in almost every excavation context.

In October 1999 we are beginning two years of intensive fieldwork, our mission for the millennium. Our goal is to clear the overburden and scrape the surface of the third-millennium BC deposits over broad areas in order to see the basic outlines of the architecture. Based upon our results in TBLF, we expect that the pat-

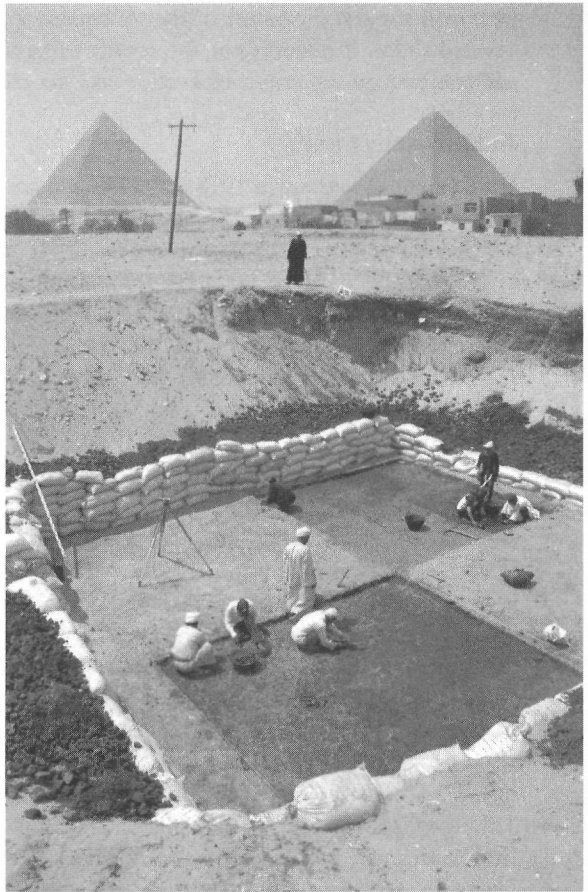

Figure 9. LNE, 10 × 10 m excavation square, looking northwest

ARCHAEOLOGY

terns will suggest the nature of the settlement and the context for what we have excavated so far. If it works out, the results will guide us in choosing where to expand and continue our intensive excavation and sampling of material.

Acknowledgments

For successful seasons in 1998 and 1999, we are grateful to Dr. G. A. Gaballa, Secretary General of the Supreme Council of Antiquities, and Dr. Zahi Hawass, Director General of Giza and Saqqara. We thank Mr. Sabry Abd al-Aziz, and Mr. Ahmed al-Hagar, Directors of Giza for their kind assistance. We are grateful to Mr. Mahmoud al-Afifi, Chief Inspector for Giza, and Mansour Radwan, Senior Inspector for their assistance. We thank Ms. Sana'a Fouad and Ms. Heba Ragab who represented the Supreme Council of Antiquities at the excavation site. We would like to thank Mr. Mohammed Youseff and Mr. Essam Bibers, who served as our inspectors in the storeroom.

Our 1998 and 1999 fieldwork was made possible by the financial support of David Koch, the Ann and Robert H. Lurie Family Foundation, Bruce Ludwig, and Jon Jerde. Robert Lowdermilk, Glen Dash, Matthew McCauley, David Goodman, Fred and Suzanne Rheinstein, the Max and Marjorie Fisher Foundation, Dr. Marjorie M. Fisher, Sandford and Betty Sigoloff, Victor and Nancy Moss generously supported our work. Additional support was provided by Don Kunz, Arthur and Bonnie McClure, and William and Kathy Dahlman.

The 1998/99 team consisted of Mark Lehner, director; John Nolan, University of Chicago, archaeologist and assistant director; Richard Redding, Michigan Museum of Natural History, faunal analyst; Mary Anne Murray, Institute of Archaeology, University College, London, archaeobotanist; Nicholas Conard, University of Tübingen, lithics analyst; Cordula Werschkun, University of Tübingen, assistant lithics analyst; McGuire Gibson, University of Chicago, archaeologist; Peter Lacovara, Museum of Fine Arts, ceramicist; Selima Ikram, American University in Cairo, assistant ceramicist; David Goodman, surveyor; Carl Andrews, database manager and photographer; Mohsen Es-Sayyad, University of California, Los Angeles, archaeologist; Fiona Baker, Firat Archeological Services, archaeologist; Justine Way, University of Chicago, archaeologist; and Noha Lila, Supreme Council of Antiquities, artist.

HADIR QINNASRIN

Donald Whitcomb

This report presents a new excavation on behalf of the Oriental Institute in Syria. Work at Hadir Qinnasrin began as a truly international project. Professor Marianne Barrucand of the Sorbonne was the principal organizer of the project with the active

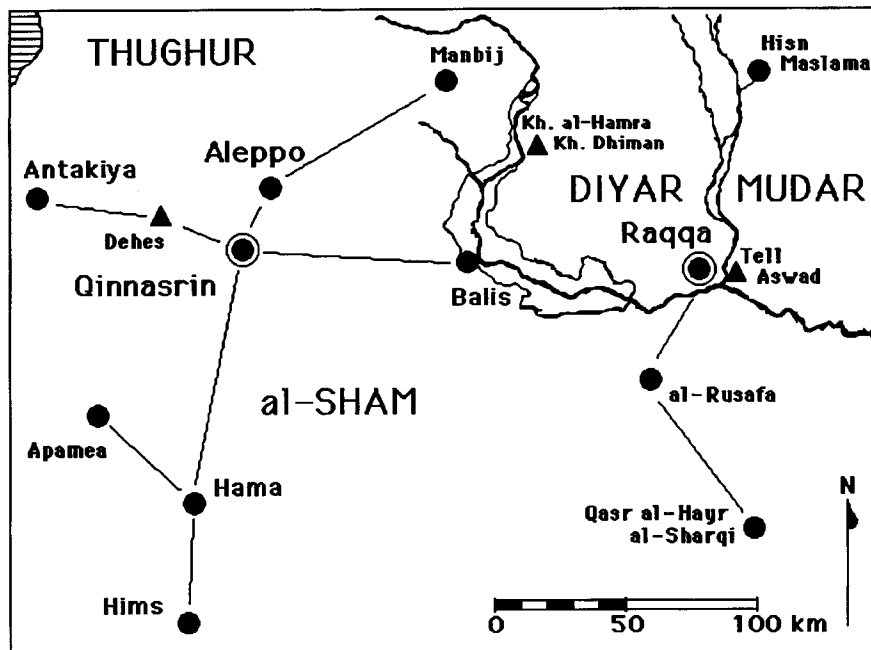

Figure 1. Map of northern Syria

assistance of the Institut français d'études arabes de Damas (IFEAD) and Institut français d'archéologie du proche-orient (IFAPO); our thanks especially to MM. Dominique Mallet and Jean-Marie Dentzer, the respective directors. Our valued guide to excavation and survey in northern Syria was Professor Claus-Peter Haase of the University of Copenhagen. The project enjoys the support of the Directorate general of Antiquities and its director, Professor Dr. Sultan Muhesen; Ms. Fedwa Abido from Aleppo served as our department representative. I functioned as the field director for the project. Two French topographers and French and Syrian students completed the international team. The next season, scheduled for fall 2000, we hope will have much larger American — and Oriental Institute — representation.

Hadir Qinnasrin is located about 25 km (10 miles) south of Aleppo, just east of the main road connecting Aleppo with Hama, Homs, and Damascus. Being so close to Aleppo, one may note first some of the archaeological aspects of that city. Aleppo was known as Beroia in the classical period; its classical structure, as Sauvaget demonstrated in the seminal study of its topographic transformations (1941), was still evident at the time of the Muslim conquest (ca. 638). The Seleucid foundation probably initiated the street pattern with insulae of 100×45 m and juxtaposition of the town and a citadel, a common Seleucid settlement pattern; indeed this pattern is probably much older as witnessed in the citadel itself. Little is known about the extent of destruction inflicted on Aleppo during the Persian attack of Khosrow in 540 or its reconstruction under Justinian. The apparent lack of attention paid to Aleppo after the Muslim conquest suggests that Aleppo was a minor center during the early Islamic period and revived only as the Hamdanid capital in the tenth century.

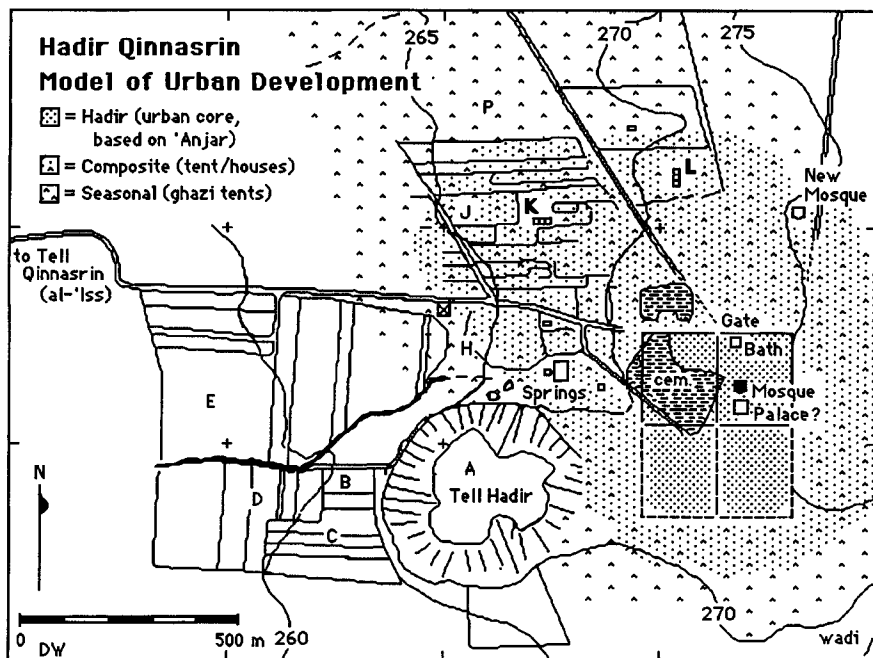

Figure 2. Map of Hadir Qinnasrin

The Muslims selected another settlement as their administrative center (*jund* capital) for northern Syria. This was Qinnasrin, long identified as Chalcis ad Belum. The layout of Chalcis with its citadel and lower town (see below) made of white limestone suggests another Seleucid foundation. As Tate notes, “the wall of Chalcis ... delimited a space ... measuring about 1000 × 900 m, remarkable for a city of the interior.” The town functioned as a Byzantine military center on the road from Antioch toward the Euphrates, the key of the eastern limes (frontier). During the Muslim conquests in northern Syria, Chalcis was the scene of a treaty (in 637, according to Kaegi), which allowed the Byzantines to evacuate civilians and forces from the region. The site of Chalcis (later known as Eski Halab) is a mound beneath the shrine of Nabi ʿIs; it was first mapped by Brossé in 1919 and again by Lauffray in 1942/43, and both descriptions and photographs were included in the historical topography of Mouterde and Poidebard in 1945. While there is little doubt that this long tradition of French scholarship has correctly identified the classical site of Chalcis ad Belum, the continuation of this site in the early Islamic period as the *jund* capital of Qinnasrin is less studied and assured.

Qinnasrin was founded as a new *jund* by Muʿawiya while he was governor of Syria in 643. There are other reports that Muʿawiya’s son, Yazid I, both “destroyed the walls of the city” and “built the capital of the *jund*” in 680. A cursory examination of Chalcis in 1990 begins to explain this apparent confusion. The classical site had very few Islamic artifacts, suggesting that Islamic Qinnasrin should be sought elsewhere. Yazid had dismantled Byzantine defenses of the old city and built a new military headquarters and capital (i.e., a *misr*). The solution came from a survey by Claus-Peter Haase, who noted a low, mounded site 4 km to the east by the name of



Figure 3. Photograph of Area K. Hadir Qinnasrin

Hadir. This name excited our interest since Aleppo and many other classical cities of Syria had pre-Islamic Arab camps outside the city walls. Such camps are frequently described as transient assembly points for the great commercial caravans and their inhabitants as bedouin organized as caravaners. Irfan Shahid suggests that these camps soon became established settlements with permanent architecture, called *parembolais* in Greek and *hadir* in Arabic. The *hadir* was an ethnic suburb inhabited by Arab tribesmen; as the historian Baladhuri notes, “the *hadir* of Qinnasrin had been settled by the Banu Tanukh since they first arrived in al-Sham and pitched their tents there. Later they built their houses in it.” The relationship of these suburbs and their adjoining cities seems similar to the association of Islamic urban foundations and an older pre-Islamic city: for example, Fustat with Babylon; al-Basra with Khuraiba; and Kufa with al-Hira. Our working hypothesis is that the Muslim conquerors avoided the alien, classical cities and settled in the *hadir* among fellow Arabs. The resulting settlements developed into cities of a distinctly Arabian type; the incipient Islamic city may be recognized in this urban form. The *hadir* became a *madina* (the traditional term for city) in a land where there had been little Byzantine building and an overall stagnation of urban life.

Armed with this hypothesis on the historical importance of Hadir Qinnasrin, we arrived at the site for a brief season of survey and sondages. One of the first things we noticed was that Hadir was no longer a village and the town of Hadir had expanded to encompass much of the low mounded area of the former city. The initial survey, or better a reconnaissance, of the town and its periphery was necessarily a matter of chance observations within empty lots, gardens, and fallow fields. This situation and the limited resources available made a systematic survey unfeasible at this preliminary stage. The oldest portion of Hadir appears to be centered on the mosque, which may overlie an earlier structure (see fig. 2). Immediately west of the

ARCHAEOLOGY

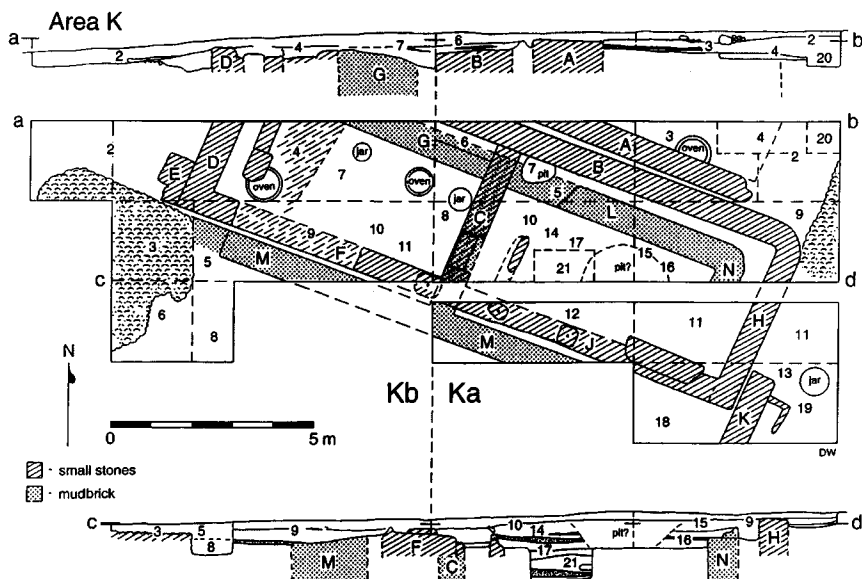

Figure 4. Plan of excavations in Area K. Hadir Qinnasrin

mosque is the cemetery, measuring about 250×150 m; its contours and dense accumulations of sherds resembles occupation mounding and suggests an earlier residential function. A long stone in the cemetery, possibly a lintel, carries an apparent Kufic inscription.

The survey began with the most obvious antiquity, the mound of Tell Hadir (area A). The tell covers an area about 500 m in diameter and towers some 15 m above the springs, which lie immediately on its north side. The artifacts collected on the mound and to its west (areas B and C) belong to the Bronze Age and indeed these early materials were scattered throughout the survey and excavations. Field scatters to the west, north, and south were investigated; the latter suggested the possibility of occupation and indicated the need for further survey south of the mound, as local informants had suggested. The fields north of the tell (areas H, H1) produced sherds that, when added to the fragmentary architectural fragments near the present Baladiya offices, suggest a Byzantine or transitional occupation in this vicinity. Further collections were made along the west slope of modern occupation (roughly between the 265 and 270 m contours). This slope produced a consistent range of collection as far as the Wadi Turab (area P), where modern fields hindered further investigation; the area is currently known as Rasm al-Ahmar. There was no indication of architectural remains visible on the surface; nevertheless, this area was selected to attempt two soundings, areas L and K.

Sondages

Area L was a very promising mound composed of a distinctive red-yellow soil; in fact, it proved too promising, being made of mudbrick of a most difficult type to delineate. This exercise in frustration was alleviated only by the excellent ceramics and other artifacts recovered. The sondage in area K proved to be luckier; this was a



Figure 5. Glazed pottery of the early Islamic period

flat area, hemmed in by houses, revealing walls made of small stones immediately beneath the surface. During the 10 days available, a pattern of stone walls emerged and in the last few days, antecedent walls made of mudbrick were found.

While the ceramic types are very similar in both areas K and L, the structural remains in area K present two distinct phases: the earlier phase was a series of mudbrick walls forming a two-room building while the later phase saw these walls replaced by stone walls in the same configuration. The first ceramic phase is characterized by cooking pots, storage vessels, and other ceramic objects well known from north Syria and typified in the late Byzantine site of D  h  s. However, a number of ceramic types common at D  h  s appear to be absent from Hadir Qinnasrin, suggesting the chronological overlap is not complete. At present, it appears that the correlation of these and other sites in north Syria point to a very late Byzantine, or better, a transitional Byzantine/early Islamic date, roughly late seventh or early eighth century.

It seems that the architectural renovation of phase 2 follows directly with little or no gap in the occupation. The second ceramic phase is characterized by the introduction of glazed wares. The style of these first glazed wares is perhaps the most interesting and important result of this preliminary excavation. This ceramic type is a splashed polychrome style of yellow or white base with green and brown accents.

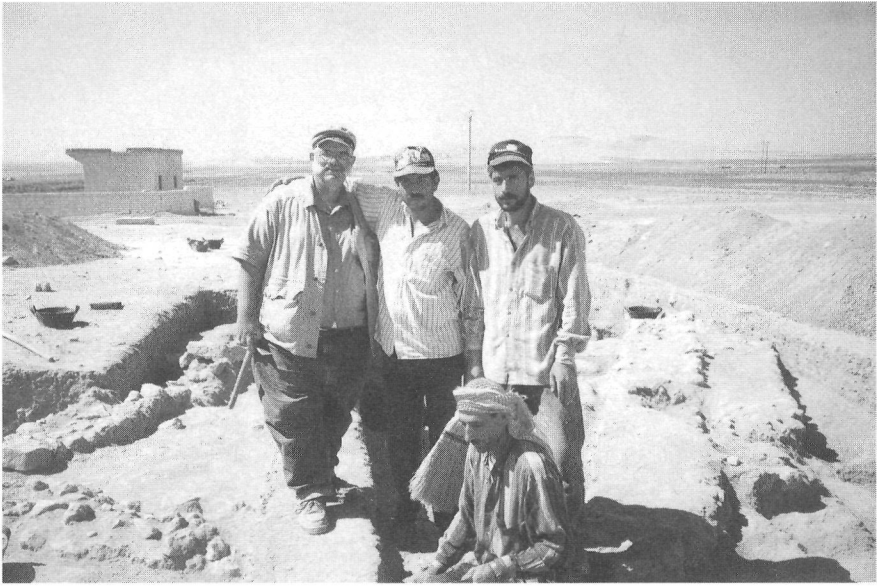

Figure 6. Donald Whitcomb (left) and team

The forms are invariably simple bowls with a low ring base. This has been labeled “yellow ware” by Oliver Watson on the basis of production collections from Tell Aswad near Raqqa. It is also found at Rusafa, Madinat al-Far, Qasr al-Hayr al-Sharqi and other early Islamic sites in north Syria.

This common glazed ware is also well known from excavations at Abu Gosh and Khirbat al-Mafjar in Palestine. More recently, the materials from Tell Yoqne’am (Qaymun, near Haifa) have clearly demonstrated the transitional nature of this ware between Coptic glazed ware (a late Umayyad Levantine tradition) and the introduction of Samarran wares (an eastern tradition of the early ninth century). Furthermore, the evolution of Coptic glazed ware (or slip-painted lead-glazed ware, according to Scanlon) suggests an Egyptian antecedent for this new style, which was subsequently developed in Bilad al-Sham. As often as this ware has been found, its stratigraphic relationship with late Byzantine/early Islamic ceramic styles has not been clear until the trenches at Hadir Qinnasrin.

The preliminary interpretation of the ceramic collections from Hadir Qinnasrin is that this innovation of ceramic production, the technique of glazing that becomes a diagnostic indicator of early Islamic culture, was a common feature of pre-Samarran culture in Syria. Moreover, the relationship of “yellow ware” to brittle wares, molded juglets, and early sgraffiato becomes clearer as these fall into a developmental sequence in these excavations. One may note that these excavations produced no evidence of occupation after the tenth century. This was predictable from historical accounts of the destruction and decline of Qinnasrin. Thus the present collections of ceramics offer a clear separation of early Islamic from the common Ayyubid/Mamluk types in north Syria. While many indications must remain preliminary, these ceramics seem to offer chronological diagnostics for the eighth century (a minimal period of AD 700 to 800), an assemblage of glazed and

common types that may refine the dating of excavations and surveys in Syria for the early Islamic period.

From Tent to House to Arab City

If we return to the plan of area K (see fig. 4), one sees an apparently freestanding structure composed of two rectangular rooms. Moreover, the plan seems to have been made first in mudbrick and then duplicated in stone cobbles. The smaller of the rooms has a couple of ovens and storage vessels. One of the more curious features is the south (actually southwest) wall, which had a series of column bases and was mostly open. These features add up to a very specific house form, a type derived from the “black” tent used by Arab tribes in the recent past. The transition of a nomad tent into more permanent material is not so uncommon. Ethnographic study of nomad tribes in Syria has documented a temporary house called a *sibat*, used for seasonal occupation and very similar to the remains that we uncovered.

The literature on Arab tribes in Syria is extensive and much of this documentation has concerned typologies and processes of settlement. This is hardly surprising in that much of the impetus to study was from mandate and later administrations with an interest in settlement of “nomad” groups. In his study of the archaeological evidence of nomads, Cribb makes an important point that the nomad camp is always, despite its appearance to occasional outsiders, a highly structured spatial arrangement of residential units. In the case of Qinnasrin, it seems likely that the form of the *hadir*, the original camp structure, influenced the development of the settlement. Such camp settlements were part of the common experience of tribes in Arabia and brought with the Tanukh and Tayy tribes when they entered Syria. The early Muslims must have found this a conducive environment when they entered Syria and founded their *amsar*. The *amsar* were more than camps, however, but founded as urban administrative centers upon Arab urban models. The sites of 'Anjar in Lebanon or Aqaba in southern Jordan may contain reflections of these models and their adaptations. When the early Muslims rejected settlement in Aleppo and Chalcis in favor of Hadir Qinnasrin, they might have selected the familiar ethnic pattern of Arab tribes and at the same time initiated a fundamental step in the development of the early Islamic city, an urban type to have wide influence in the formation of Muslim communities in Syria and throughout the Middle East.

JOINT PREHISTORIC PROJECT

Robert J. Braidwood and Linda S. Braidwood

The situation in southeastern Turkey, unfortunately, is still unchanged. Actually with the capture and sentencing of the militant PKK Kurdish leader, and his statements to the judges, there is a glimmer of hope that the violence and killings will stop.

ARCHAEOLOGY

We have nothing exciting to report at this time but are glad that work towards publication does go forward with Aslı Özdoğan in charge of the Prehistoric laboratory in Istanbul University. She is still hopeful that she is going to resume excavation on Çayönü in the near future. Meanwhile she is excavating a site not too far from Çayönü to test the general situation.

Isabella Caneva and her Italian colleagues have been moving forward on the large bulk of chipped flint and obsidian. Unfortunately, they can only leave their work in Italy to come out to Istanbul for several short study periods each year. The Prehistoric Project has been able to pay the small monthly sums needed that make it possible for Çiler and Güner, the two Turkish women, to keep working on the chipped stone in their absence. They were thrilled to be sent to the chipped stone symposium Isabella held in Venice last November. There they were able to meet chipped stone specialists from all over Europe and the United States. They also presented their first papers, which were well received.

Gülçin and Banu, the two Turkish women who first began to work on animal bones under Berrin, are also doing very well. After Berrin's tragic death, both women wanted to keep working on sorting and learning about the bones that had been excavated. So when Richard Meadow of Harvard and his graduate student Hitomi Hongo (Ph.D., Harvard) took over the bone study, the women were needed. As we reported in an earlier *Annual Report*, Richard received a grant from the National Science Foundation for the work on Çayönü, and Hitomi, who now has a permanent position in a Japanese research Institute, was permitted to use Çayönü as her research study. This means that she can come out to Istanbul for two or three long study sessions each year and also supervise the women's work. Both Banu and Gülçin have been able to specialize on an animal (red deer and cattle) so they were able to obtain their master's degrees from Istanbul University. Richard Meadow is trying to find a way so that each woman can eventually get a higher degree in zooarchaeology in Europe or the United States. This will undoubtedly prove too difficult financially. They must first have more English lessons (or the needed European language).

There is still work to be done to straighten out some of the details of the Çayönü stratigraphy — this needs to be done by the three staff members, Aslı, Erhan, and Mike Davis. We are hoping that Mike will be able to leave his pet project in New York (that of getting people back to using the New York harbor for rowing) this winter to spend several weeks in Istanbul working on the stratigraphy.

Before we close, we want to thank warmly all the friends of the Prehistoric Project for their continued interest and support.

NIPPUR AND UMM AL-HAFRIYAT

McGuire Gibson

At the risk of repeating myself, I can report once again that real progress was made in publishing results of excavations carried out before the Gulf War in Iraq. Most tangible was a substantial article that appeared in the British journal *Iraq* during the past year. Entitled "The City Walls of Nippur and an Islamic Site Beyond," the piece was written with James Armstrong and Augusta McMahon, with architectural interpretation by John Sanders. This article reports on the results of the seventeenth season (1987) at Nippur when we were able to work out the history of city wall building at the city and, in addition, investigated an Islamic site about a few hundred meters northeast of the ziggurat. The Islamic site was a small town that had been occupied in the fourteenth century AD, just after the Mongols had conquered Iraq. The town had been completely covered over by sand dunes from sometime after 1920 until the mid 1980s, when it was exposed by the moving away of the dune belt that has made Nippur both beautiful and difficult as a site to excavate. Maggie Brandt, a student working on an environmental project, noticed the beautiful cobalt blue glazed pottery on the site when she was investigating the traces of ancient irrigation northeast of Nippur. I had been over that area dozens of times in the past, but had never seen anything because I had been traveling over sand. The low profile of the site, and the uniform assemblage of artifacts on the surface, suggested that the town was occupied only a short time, maybe less than a century. Thus, we thought that in one season we could expose a good deal of the town plan. There have been almost no excavations of sites of the fourteenth century, meaning that this operation would have importance beyond the site itself.

Because mudbrick walls hold moisture longer than the looser soil around them, we could see many of the walls of the houses and could pick up sherds room by room. After collecting from the surface artifacts that included sherds, coins, glass, iron tools, and even the hardware from doors, James Armstrong began to dig a pit in one room of a house. Within a short time, it was evident that the site would yield no more information than that which was visible on the surface. Wind and water erosion had erased all but a centimeter or two of the walls and had left only traces of the dirt floors in the rooms. With a sweep of the trowel, we were in the sterile soil under the buildings. Despite our disappointment in excavation, we were able to derive a good deal of information on the site from the surface scatter alone.

Excavations on the northeastern stretch of the city walls, carried out by Augusta McMahon, were more fruitful. We were able to supplement the information derived from the old excavations done on the walls by Pennsylvania in the 1890s and were able to add much new detail. But the size of the problem was too great for us to resolve unless we removed many tons of Parthian construction (ca. AD 100) from above the ancient walls, which dated to the Early Dynastic, Akkadian, and Ur III periods (2900–2100 BC). Thinking that we would have many future seasons to resume this work on a grand scale, we shifted to the southern corner of the city, Area WC, where we had found remains of city walls of the Ur III (2200–2100 BC) and Kassite (ca. 1300 BC) periods, but nothing earlier. This seeming lack of match



Area WC. Nippur

between city walls on one end of the city and the other needed resolving. For example, it was still not certain that the Ur III wall was the earliest one at that part of the site. We cut a 3 m wide trench through the walls that resulted in a clear picture of the succession of fortifications. Here, we found evidence of city walls with moats cut not only in the Kassite period, but in the early Neo-Babylonian period (seventh–sixth centuries BC) as well. And we could prove definitely that there was no occupation, and no city walls, in the WC area until the Ur III period. We concluded that the city of Nippur had been much smaller until Ur III times, when it had expanded greatly. Subsequently, it shrank in size and presumably population, growing to its full size in only two other periods (Kassite and early Neo-Babylonian) when Area WC was once more occupied and fortified.

We had actually prepared a report on all this work and had submitted it to the Iraqi journal *Sumer* in 1988. The Gulf War caused disruptions in the operations of the Department of Antiquities, including the publishing of the journal. In order to make sure that the information would be published, we revised the article a couple of years ago and submitted it to *Iraq*.

More comprehensive, final monograph publications are in progress. Augusta McMahon, who now teaches at Cambridge University has revised her dissertation on the critical transition between the Early Dynastic and Akkadian Periods (ca. 2350 BC). The manuscript has been read and returned to her for minor revisions. It will be submitted formally to the Oriental Institute Publications Office in September 1999 and should appear as an Oriental Institute Publication within a year of that date.

Judith Franke, now the director of the Dickson Mounds Museum in downstate Illinois, did, as she promised last year, take time off to work on the report she has been preparing on Area WB, where an Old Babylonian bakers' house (ca. 1800 BC) was found under a thirteenth century Kassite administrative palace.

James Armstrong, Curator of the Harvard Semitic Museum, has spent a good part of the last few months working on his important book on the archaeological and historical evidence for Nippur from the Kassite period through the early Neo-Babylonian (thirteenth–sixth century BC).

Here in Chicago, I have found a bit of time to work on the manuscript of Area WG, in which we exposed a very important sequence of material from Parthian into Abbasid times (ca. AD 100–900). This report is almost complete since I have in hand a number of chapters by other collaborators.

Also during the year, a graduate student, Jason Ur, entered the basic data from Umm al-Hafriyat into a computer database. With a couple of months of free time, I should be able to write up much of the report on this site, which is a specialized pottery-producing town out in the desert east of Nippur.

Unfortunately, as time passes, we seem no nearer to resuming work at Nippur. The Iraqi Directorate General of Antiquities would like us to return, but the embargo keeps us out. In the meantime, there has been a great deal of destruction of sites caused by illegal diggers, and the Directorate is so understaffed and underfunded that it can do almost nothing to stop it. So far, Nippur has not been damaged in this way. The guard on the site is apparently effective. We do hear of illegal digging at Tell Bismaya, ancient Adab, a site that is about 35 km southeast of Nippur. We have learned that tablets and other inscribed items from Bismaya are appearing on the international antiquities market. Bismaya was the first site that the University of Chicago dug in the Near East, in 1904/05. Some of the most important artifacts that were on display in the old Mesopotamian gallery are from those excavations.

The Directorate of Antiquities is going to start small excavations at some major sites that have been badly damaged, in the hope that this activity will deter the illegal diggers and slow down the smuggling. A member of the Directorate recently sent me photographs of one site, ancient Umma, which is a very important Sumerian center. In the photographs, there are dozens of square-cut, huge gouges in the tell, left by bulldozers or front-end loaders. The damage to that site is irreparable, and the inscribed antiquities from the site that have passed through London in the past few years has been described as “a flood.” This trade is, of course, illegal, but little has been done to stop it in Europe or the United States. In Baghdad, one official of the Directorate who was actively trying to halt the trade in Iraq was recently stabbed “by an unknown assailant.” He survived the attack.

The key to our work in the Near East has always been the welcome and collaboration we receive from well-trained professional archaeologists and philologists from the host countries. In the past nine years, both the Directorate of Antiquities and the Iraqi universities have lost dozens of archaeologists and philologists with doctorates from Europe and the United States. These men and women now teach in Jordan, the Gulf, Yemen, and Libya or work in completely different fields in Iraq or in the United States, Canada, and Europe. Even if normal archaeological work were to resume in Iraq tomorrow, it would take a generation or more to reconstruct the Iraqi Directorate of Antiquities and the Departments of Archaeology at the University of Baghdad and elsewhere. This loss of expertise, rather than the damage to sites or museums, is the most harmful, lasting effect on the world’s heritage of the war and the embargo.

Given the current conditions, our publications and those of our colleagues elsewhere take on greater importance. It is these publications that preserve the archaeological record and lay the groundwork for training a new generation of scholars, not only in Iraq but in the rest of the world.

For this reason, the continued support of the Nippur project by Oriental Institute members is even more important, and is gratefully acknowledged.

TELL ES-SWEYHAT

Thomas A. Holland

During this academic year, the pottery type series of forms was completed for the Bronze Age and for the Hellenistic and Roman periods of occupation at Tell Es-Sweyhat for inclusion in a forthcoming Oriental Institute Publication report. Although the pottery from the Bronze Age and the Hellenistic period has been previously reported upon in some detail (see *Levant* 8 and 9, 1976, 1977), an assessment of the Roman period remains has not been published.

The Roman occupation at Sweyhat was centered primarily on the lower and flatter surface of the southern side of the main Early Bronze Age mound in the region of the Area I trenches; building foundation stones also were *in situ* in the area to the north of Area I and also in Area XI to the northeast of Area I (see *Levant* 8, fig. 1). During the 1991 and 1992 seasons, a large 10 × 10 m square, labeled Operation 5, was excavated just to the north of Area I, Trench IA2 (see *News & Notes*, no. 134, 1992, fig. 1), which had at least three phases of Roman occupation overlying the mid-third millennium BC building that contained the wall paintings, which have already been discussed in previous annual reports. Even though no complete Roman buildings have thus far been excavated, a great deal of information is now available concerning the material remains and the dating of the Roman occupation at Sweyhat, particularly from the 1970s excavations conducted in Area I, Trenches IA1 and IA2 (fig. 1).

Trenches IA1 and 2 were two 5 × 5 m squares laid out parallel, west and east, to each other in Area I with a one half meter balk between them (fig. 1a–b); both trenches were only excavated to about 1 m in depth, but they revealed four major phases of occupation (see sections, fig. 1c–d) and Trench IA2 contained an Aramaic inscription (fig. 2a) as well as two Roman coins (fig. 2b–c), which offer valuable evidence for the dating of the Roman pottery assemblages at Sweyhat. The earliest phase of occupation, Phase I, represents the initial appearance of the Romans at Sweyhat and is most likely associated with a temporary camp set up before buildings were constructed for a more permanent settlement as the Roman pottery from this phase is mixed with Bronze Age pottery forms dated to the last quarter of the third millennium BC; this early phase of Roman occupation included an oven and re-

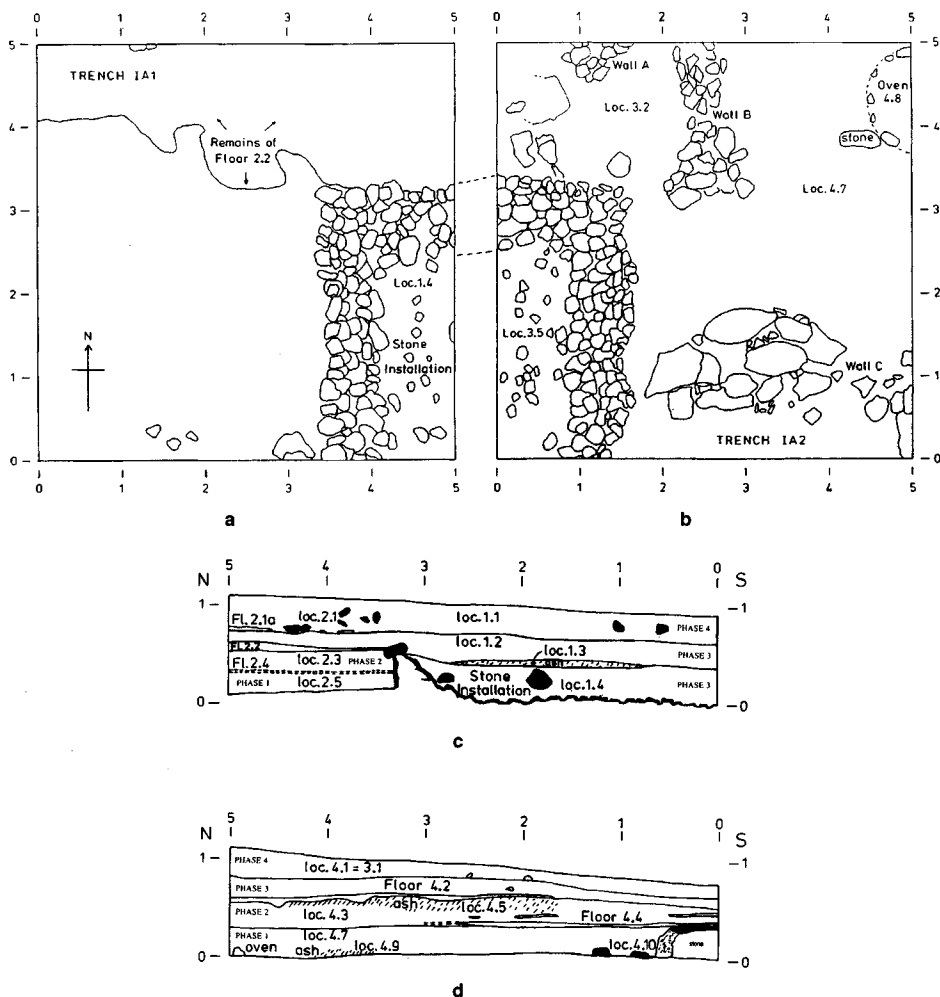

Figure 1. (a–b) Area I, Trenches A1 and A2 plans and (c–d) Trench IA1 east section and Trench IA2 east section. Tell es-Sweyhat. Scale in meters

mains of a rough stone-built Wall C, partially excavated in the northeastern corner of Trench IB and the southeastern quadrant of Trench IA2 (fig. 1b). More permanent occupation was established by Phase 2 with the appearance of plastered floors belonging to unexcavated structures in both Trenches IA1 and 2; they are Floor 2.4, partially excavated in the northeastern corner and west side of Trench IA1 and the remains of Floor 4.4, on the eastern side of Trench IA2 (see sections, fig. 1c–d). During Phase 3, a stone-built, pit-like installation approximately 4×4 m square was constructed for some unknown industrial purpose; it was associated with Floor 2.2 in Trench IA1 and with Floor 4.2 in Trench IA2 (see plan, fig. 1a–b and photograph in *Levant* 8, pl. 4B). Phase 4 had been heavily eroded, due to wash down the southern slope of the mound from the higher accumulation of occupation to the north above the basal Bronze Age mound and the Hellenistic occupation in Area II above

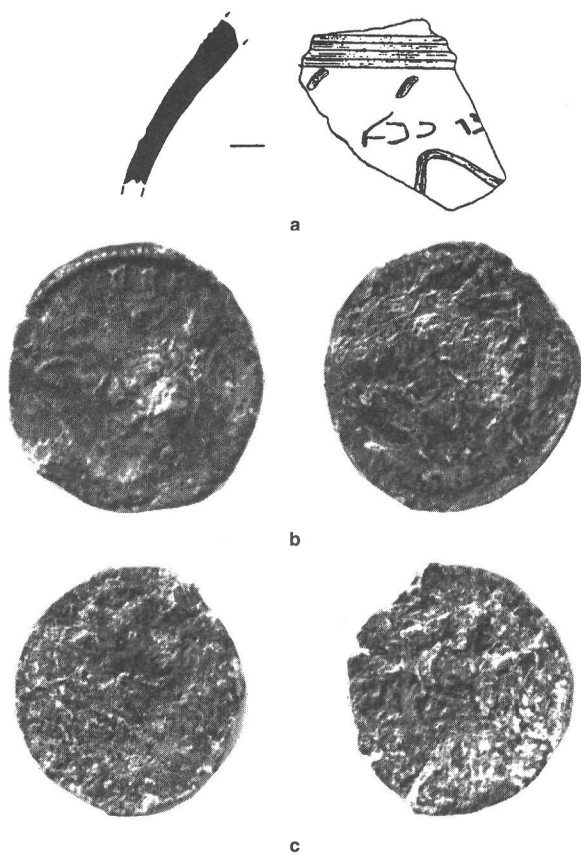

Figure 2. (a) Sherd with Aramaic inscription, scale ca. 2:5, and (b-c) Roman coins, scale ca. 2:1. Tell Es-Sweyhat

the basal mound. However, Phase 4 did contain traces of a plaster floor, Locus 2.1a and a collapse of wall stones, Locus 2.1, in Trench IA1; in Trench IA2, there were remains of stone wall foundations, Walls A and B, in the northern end of the trench (fig. 1b). Both trenches contained a large assemblage of Roman pottery forms belonging to Phase 4.

The earlier Roman occupation at Sweyhat, Phases 1 and 2 in Trenches IA1 and 2, is dated on the evidence from a jar sherd found on Floor 4.4, Phase 2, that had the remains of an Aramaic inscription incised on its shoulder (fig. 2a). This inscription was translated and dated by Professor J. B. Segal to about the first century AD and not much later than the second century AD (*Levant* 8, p. 38, photograph, pl. 8A). A selection of Roman pottery forms from Phase 2 in both Trenches IA1 and 2 is presented here in figure 3. This

pottery assemblage partly consisted of one miniature bowl (fig. 3:1), twelve bowls (fig. 3:2-13), two large jars (fig. 3:14-15), two holemouth-type storage jars (fig. 3:16-17), one handled-type jug (fig. 3:18), one cooking pot rim sherd (fig. 3:19), fragments of a bottle and lamp (fig. 3:20-21), and a jar shoulder sherd with incised decoration (fig. 3:22). Unfortunately, most of the bowl and jar forms are of the common ware, local Euphrates, type of vessels, for which there is little published comparable material. However, similar parallels exist for the holemouth jar, the cooking pot, and the lamp (fig. 3:17, 19, 21). The large holemouth-type storage jar from locus 2.3 is similar to a survey example from a site called Ech Chamel, located near the Nahr Sajour river, Site 94, on the upper Euphrates River north of Sweyhat (see de Contenson, fig. 18:14, in P. Sanlaville, ed., *Holocene Settlement in North Syria*, 1985). The brittle ware cooking pot, red-orange ware painted red inside and outside, from locus 4.3 (fig. 3:19), is comparable to examples from the Roman settlement at Ain Sinu in northern Iraq in the Castellum and the Barracks (see D. Oates, *Studies in the Ancient History of Northern Iraq*, 1986, fig. 23:81) and from the site of Samaria in Palestine (see J. B. Hennessy, "Excavations at Samaria-

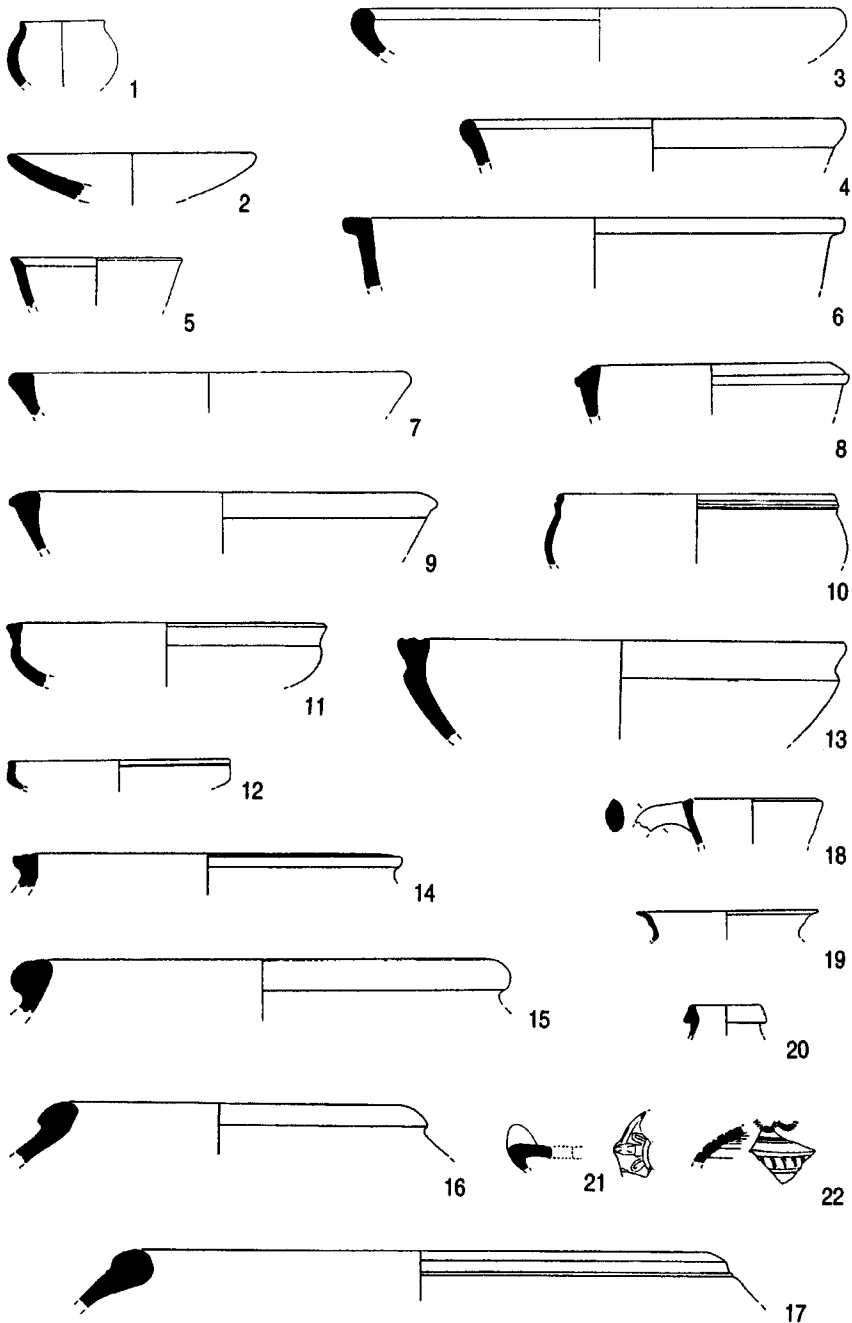

Figure 3. Phase 2 pottery. Tell Es-Sweyhat. Scale 1:5

Sebaste, 1968," *Levant* 2 [1970]:1–21, fig. 8:4). The lamp fragment (fig. 3:21) is a well known type known throughout the Roman Near East and compares, for example, to similar types at Tell Abou Danne in Syria (see R. Tefnin, "Les niveaux superieurs du Tell Abou Danne," *Syro-Mesopotamian Studies* 3/3 [1980]:109–68,

ARCHAEOLOGY

fig. 17:12) and to those found in the Mount of Olives Cemetery in Jerusalem (see P. B. Bagatti and J. T. Milik, *Gli Scavi del "Dominus Flevit" [Monte Oliveto — Gerusalemme] Parte I: La Necropoli del Periodo Romano*, 1958, fig. 25:17).

The later part of the Roman occupation at Sweyhat, Phases 3 and 4 in Trenches IA1 and 2, is dated on the epigraphic evidence provided by the two Roman coins that were found in the eastern side of the Phase 3 stone installation from Locus 3.3 (fig. 2b–c). The dating of these coins by Dr. Colin Kraay of the Ashmolean Museum, Oxford University, was published in *Levant* 8 (1976), p. 38; his description of the coins was: "Coin SW.235 [fig. 2b here] is of Constans or Constantius II, minted ca. AD 350, and has the inscription 'Ry Fel Temp Reparatio (fallen horseman). Coin SW. 236 [fig. 2c here] seems to be Roman Imperial of the mid or later fourth century AD to judge from the head on the obverse. The reverse type is obscure."

A selection of pottery from Phase 3 is given in fig. 4, which includes another miniature bowl (fig. 4:1), two small shallow bowls (fig. 4:2–3), two wide bowls (fig. 4:4–5), three fairly high-necked storage jars (fig. 4:6–8), two holemouth jars (fig. 4:9–10), seven handled-type jugs (fig. 4:11–17), one cooking pot (fig. 4:18), and one example each of a bottle, lid, and base (fig. 4:19–21). The bowls and jugs are the best-known forms in the Phase 3 pottery assemblage. The simple shallow bowl with a slightly curved upright wall, locus 3.3 (fig. 4:3) is painted red inside and outside and is a successor to the Hellenistic red-slipped bowls, which are found in the Graeco-Roman levels on many other Near Eastern sites. The wide deep bowl with a slight ledge below the outside tip of the pointed rim, locus 1.3 (fig. 4:4) is a form known from Samaria (see G. M. Crowfoot, "Late Roman A, B, and C Ware," pp. 357–64 in J. W. Crowfoot, G. M. Crowfoot, and K. M. Kenyon, *The Objects from Samaria*, 1957, fig. 84:15) and also from Hammat Gader in Palestine (see R. Ben-Arieh, "The Roman, Byzantine and Umayyad Pottery," pp. 347–81 in Y. Hirschfeld et al., *The Roman Baths at Hammat Gader*, pl. 7:8). The jugs generally have two vertically-positioned loop handles, but in most excavated examples, only a portion of the jug neck was recovered with a portion of one handle extant; however, these jugs have good parallels at other sites. The jug with an upright neck and with its extant one handle situated well below the rim on the neck, locus 1.3 (fig. 4:11) is comparable to a two-handled example from Tell Bi'a, near modern day Raqqa south of Sweyhat on the Euphrates River (see S. Herbordt et al., "Ausgrabungen in Tall Bi'a 1981," *MDOG* 114 [1982]:79–101, fig. 5, bottom left). The jug with a concave ledge just below the inside lip of the rim, probably for the placement of a lid, from locus 3.4 inside the stone installation (fig. 4:12) is comparable to a Roman period 2a example from Samaria (see K. M. Kenyon, "Pottery: Hellenistic & Later," pp. 217–357 in *The Objects from Samaria*, 1957, fig. 70:3). The jug with a flat top rim thickened on the inside, locus 3.4 (fig. 4:16) is comparable to an example from the very large Hellenistic/Roman site of Dibsi Faraj, south of Sweyhat on the Euphrates (see R. P. Harper, "Athsi — Neocaesareia — Qasrin — Dibsi Faraj," pp. 327–48 in J.-Cl. Margueron, ed., *Le Moyen Euphrate, Zone de contacts et d'échanges*, 1980, fig. E:69). The tall-necked jug with a V-shaped groove on top of the rim, for securing a lid, from locus 1.2 (fig. 4:17) is a well-known form that occurs at Busra (see J. Wilson and M. Sa'd, "The Domestic Material Culture of Nabataean to Umayyad Period Busra," *Berytus* 32 (1984):35–147, no. 140), Hammat Gader (see Ben-Arieh

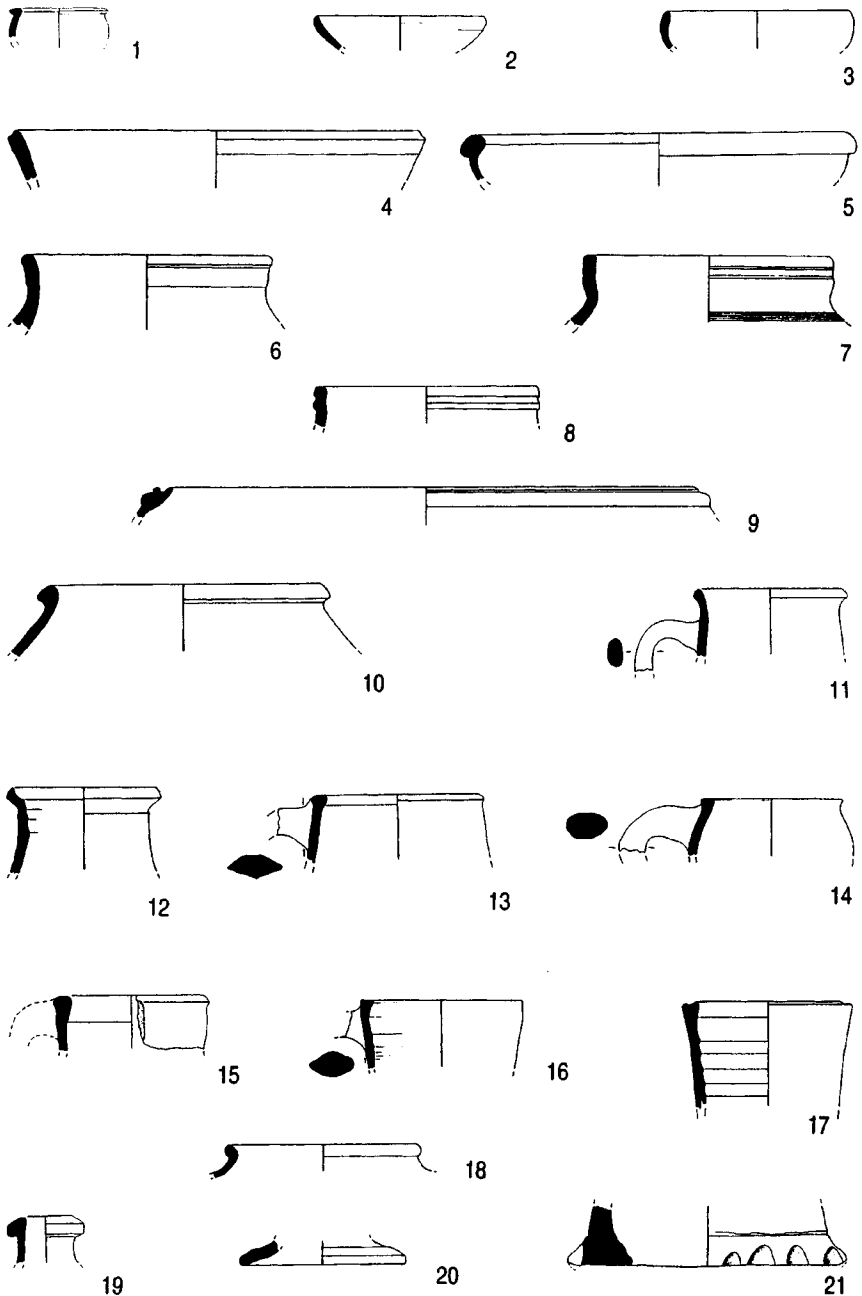

Figure 4. Phase 3 pottery. Tell Es-Sweyhat. Scale 1:5

1997 listed above, pl. 14:24), and in Turkey at Humeyli Höyük (see G. Algaze, R. Breuninger, and J. Knudstad, "The Tigris-Euphrates Archaeological Reconnaissance Project: Final Report of the Birecik and Carchemish Dam Survey Areas," *Anatolica* 20 [1994]:1-96, fig. 31:J).

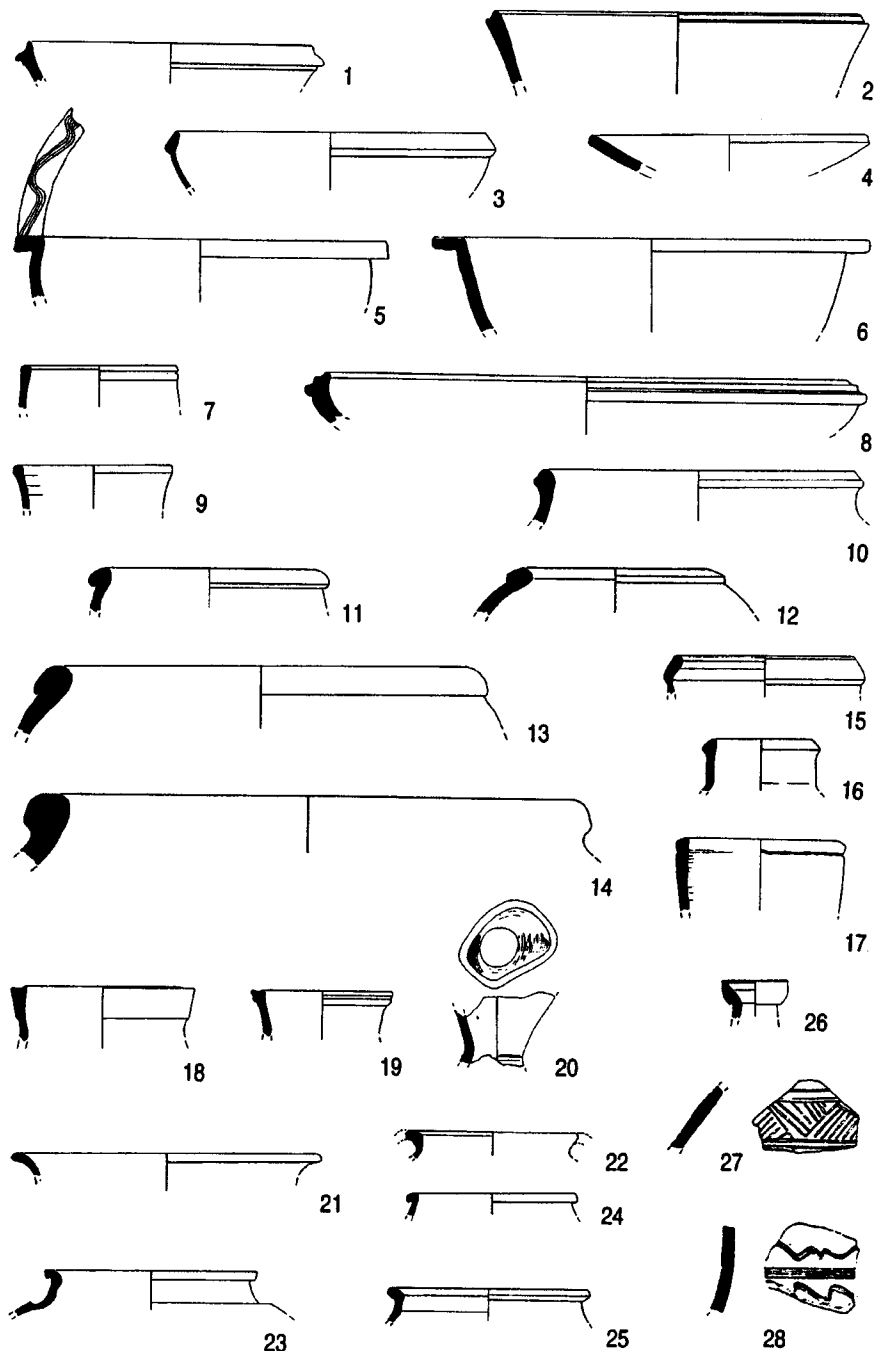

Figure 5. Phase 4. pottery. Tell Es-Sweyhat. Scale 1:5

The latest Roman pottery forms from Phase 4 in Trenches IA1 and 2 are illustrated in figure 5. The selection of Phase 4 pottery presented here includes eight bowls (fig. 5:1-8), two upright neck jars (fig. 5:9-10), three holemouth-type jars

(fig. 5:11–13), one large storage-type jar (fig. 5:14), six jugs (fig. 5:15–20), five cooking pots (fig. 5:21–25), one bottle (fig. 5:26), and two incised jar sherds (fig. 5:27–28). The deep bowl with a ledge below the outside of the rim from locus 3.1 (fig. 5:2) is similar to the example from Phase 3 (fig. 4:4); a variant of this bowl with a vertically-positioned wall was found in Jerusalem with the upper portion of a strap handle attached to the wall just below the rim (see A. D. Tushingham, *Excavations in Jerusalem 1961–1967* [1985], fig. 49:14). The fairly deep bowl with an inturned collar-type rim with red slip on its outside wall from locus 2.1 (fig. 5:3) is similar to examples from Jerusalem Site T and Hammat Gadar (see Tushingham 1985, cited above, fig. 81:41 and Ben-Arieh 1997, cited above, pl. 7:14). The wide and deep bowls with their rims folded horizontally on the outside are decorated on the flattened top of the rim with either a combed wavy line pattern (fig. 5:5) or with parallel circular lines (fig. 5:6). The bowl with the parallel circular line decoration on top of the rim from locus 4.1 (fig. 5:6) is Hayes' Form 58, Type B (see J. W. Hayes, *Late Roman Pottery*, 1972, fig. 14, 90:b); it is very similar to an example from Hama which has a fairly high pedestal-type base (see A. P. Christensen, R. Thomsen, and G. Ploug, *Hama Fouilles et Recherches 1931–1938, III 3. The Graeco-Roman Objects of Clay, The Coins and the Necropolis*, 1978, fig. 4:j). The wide bowl with a diagonally positioned ribbed collar-like rim from locus 3.2 (fig. 5:8) is similar in form to a Cypriot Red Slip Ware bowl from Jerusalem (see Tushingham 1985, cited above, fig. 65:2). The holemouth jar with a thick flat collar-type rim from locus 4.1 (fig. 5:12) is similar to a more complete example from a Roman phase in Sweyhat Trench IB, which has one extant broad vertical loop handle at the base of the shoulder with a deep U-shaped groove manufactured on the outside middle of the oval-shaped handle; these handled holemouth jars compare with an example found in the Balikh Valley Survey (see F. A. Gerritsen, "Hellenistic and Roman-Parthian Pottery from the Balikh Valley, Northern Syria," pp. 93–108 in *Oudheidkundige Mededelingen Uit Het Rijksmuseum Van Oudheden Te Leiden* 76 [1996], fig. 7:73). The jug with the rim turned diagonally inside of the neck from locus 3.1 (fig. 5:15) has a parallel in Period II at Kurban Höyük in Turkey (see G. Algaze, ed., *Town and Country in Southeastern Anatolia, Vol. II: The Stratigraphic Sequence at Kurban Höyük* [1990], pl. 141:B).

The only small finds associated with the Roman pottery assemblages in Trenches IA1 and 2 were one iron pin fragment from locus 4.3, Phase 2 in Trench IA2 and two iron nail fragments from loci 2.3 and 2.4a, Phase 2 in Trench IA1. A large amount of Roman pottery was recovered from the upper three phases in Operation 5 as well as from the other unpublished trenches in Area I, along with more numerous small finds, which will be published at a later time.

At the present time, we may conclude that there were at least four phases of Roman occupation at Tell Sweyhat, which are divided into an earlier period (Phases 1–2) and a somewhat later period (Phases 3–4) on the epigraphic evidence provided by the Aramaic inscription on the pottery jar sherd and the two Roman coins that are discussed above. The earlier period would, therefore, apparently date to first or second century AD and the later period to between about AD 350 to 400. Further study of the remaining unpublished Roman strata from the other Area I trenches may help in providing more information on the Roman pottery assemblages at Sweyhat.



Overleaf. Chicago House Field Director W. Raymond Johnson tracing inscription on support of Tutankhamun Statue in the Joseph and Mary Grimshaw Egyptian Gallery. Ray is tracing hieroglyphs onto clear acetate for the record and future publication. Photograph by Jean Grant

CHICAGO ASSYRIAN DICTIONARY

Martha T. Roth

During the 1998/99 academic year, the staff of the Chicago Assyrian Dictionary Project devoted most of our energy to the P volume. Editor-in-charge Martha T. Roth completed her reading of the entire checked 3,600-page manuscript. Appropriately, the number 3,600, Akkadian *šār*, is used in Sumerian and Akkadian idiomatically to mean "countless" and "totality." No less appropriately, at the halfway point of the P Volume we have *pitru* B meaning half a *šār* or 1,800.

Dr. Joan Westenholz joined our staff for the year, taking a leave from her position as Chief Curator at the Bible Lands Museum Jerusalem to return to Chicago. She and Dr. David Testen, assisted by our part-time research assistant Michael Kozuh, a graduate student in the Department of Near Eastern Languages and Civilizations, went through the card files that have accumulated over the decades and examined recently published books in order to eliminate outdated references. Members of the Editorial Board were also given the opportunity to review the manuscript. The manuscript editor Linda McLarnan and research associate Dr. Gertrud Farber continued to incorporate all the corrections and changes into a final master copy. The P manuscript will be sent to press in 1999.

Meanwhile, the page proofs for the R volume were all returned to our typesetter, Eisenbrauns, and they returned corrected final pages to our offices. The volume will be published in 1999, after the front matter is finalized.

The T Volume was transferred to Eisenbrauns, and T will be typeset in 1999. We anticipate that the volume will appear in 2001.

Publication and distribution were reorganized, and stock formerly held in Glückstadt, Germany, by our former printer is now in Chicago and available for distribution world-wide. Out-of-print volumes A/1, B, and Z were reprinted, and all published volumes are again available.

We again benefited from the good cheer and able assistance of University of Chicago students participating in the College Research Opportunities Program, who perform various lexicographic and clerical tasks for the dictionary. Jason Kemper and Andrew Simpson completed the computer catalog of the Oppenheim offprint collection, and Edward Schoolman began cataloging the Sachs offprint collection. Mr. Kemper completed his master's degree and will spend next year working with Dr. Joan Westenholz at the Bible Lands Museum Jerusalem; Mr. Simpson finished his bachelor's degree and will attend graduate school in linguistics at Berkeley next year. We expect to see Mr. Schoolman, a second year student in the College, return to the dictionary project in fall to continue work on the Sachs collection.

We ended the academic year by submitting a new grant proposal to the National Endowment for the Humanities, requesting funds to complete the final volumes, T and U/W, and to bring this long-running project to a successful conclusion.

CHICAGO HITTITE DICTIONARY

Harry A. Hoffner, Jr.

The staff of the project underwent only minor changes during the year 1998/99. Hans Güterbock and Harry Hoffner remained co-editors. Richard Beal, Hripsime Haroutunian, and Oğuz Soysal remained on the staff as Research Associates. Irv Diamond continued to render assistance as a volunteer. And we were occasionally assisted on-site by graduate students in Hittitology Simrit Dhesi, Kathleen Mineck, and Dennis Campbell. What did change was the degree of involvement of several colleagues off-site, who served as consultants. As we entered the homestretch in the process of preparing the manuscript for the first of two projected volumes on the letter S, it was vital to have constructive criticism of the pre-final drafts of these articles from our consultants. Two North American colleagues, Gary Beckman of the University of Michigan and Craig Melchert of the University of North Carolina, gave valuable criticisms. Melchert was particularly generous with his time and expertise. Overseas, we were able to tap the expertise of Gernot Wilhelm of Würzburg, Germany in the area of Hurrian language. All of this was quickly and easily accomplished through new computer networking capacities put into place in the Institute by John Sanders, who assisted in posting dictionary article drafts on the Hittite Dictionary Project website in a password-protected folder for access by our off-site consultants. Since the articles are posted in Adobe Acrobat format, they can be generated by project Macintosh computers but read by consultants using other platforms who do not have the project font resident in their systems.

On-site work continues to follow time-tested procedures, although we are always looking for better and more efficient methods to expedite the work. Newly published texts are entered by Haroutunian into the project computers for electronic retrieval. She also utilizes newly found duplicates and joins to update the project's text base of texts published years ago. Soysal writes first drafts of articles; currently he is preparing the last few words in the SU range before plunging into the TA words. Beal, who performs so many important functions on the project, is occasionally available to write a first draft as well. Drafts are then criticized by on-site project staff. Of particular importance are the comments of Güterbock, whose long years of research experience give him a unique perspective and deep understanding of the texts. Since his eyesight is almost completely gone, a staff member — usually Beal — reads drafts to him and records his comments and queries. These are then followed up, evaluated, and used to modify the drafts.

Since often several years pass from the time of composition of the first draft and the revisions leading to a final draft, it falls to Hoffner to add in newly published text material and integrate newly found joins and duplicates to the pre-final drafts, ensuring that they now reflect the current state of knowledge in the field. Occasionally Soysal is able to contribute information from unpublished textual material from the Ortaköy excavations that he is preparing for publication jointly with Aygül Süel, the chief epigrapher of the excavation.

When the entire manuscript has passed through the final revisions by Hoffner, the reference-checking process begins. This is a tedious and time-consuming task that so far has resisted our efforts to find ways to automate it with computers. All text citations must be checked against the original cuneiform publications for accuracy of citation, and all citations of secondary literature must be checked against the original books and journal articles. A small group of graduate students assist the Research Associates in this task. A manuscript that has been reference-checked is then edited for proper CHD format by Beal and Hoffner before being sent to the Institute Publications Office. It is this reference-checking stage that we are in at the time this report is being prepared.

We are happy to report that the Hittite Dictionary Project has been given another two-year grant by the National Endowment for the Humanities (NEH), extending from 1 July 1999 through 30 June 2001. We are also grateful for the many smaller donations to the project by Oriental Institute members and friends. We take this opportunity to express our deepest appreciation to the NEH and its helpful support staff not only for the funds, without which we could not have accomplished all that has been achieved in the past twenty years of the dictionary's life, but also for the extremely valuable advice that has come to us from Endowment staff and its academic evaluators. A major benefit of the Endowment's close supervision and advice will take the form of a site visit by members of its staff in fall 1999, at which time we will also receive advice from specialists in the computerization of lexical projects similar to ours. We expect this advice to result in greatly increased efficiency of production and greater accuracy and usability of the final product, which will most likely include some form of internet availability of the dictionary's contents.

DEMOTIC DICTIONARY PROJECT

Stephen Vinson

In the past year, the Demotic Dictionary Project has made significant progress towards closing our manuscript and preparing for final formatting and publication. The Dictionary staff this year included Professor Janet Johnson and Research Associate Steve Vinson as well as research assistants Thomas Dousa, François Gaudard, Alejandro Botta, and Brett McClain. The letters Y, W, B, F, R, L, Š, Q, Ḫ, K, T, and Ṭ are close to "done," meaning that all entries have been checked, many to most scans have been entered, and black and white facsimiles made. The letters ȝ, ʿ, ʾI, P, M, S, G, Ḫ, and D have been checked for content but await most of their scans. N and H are currently being revised, with N almost finished; only Ḫ remains in rough-draft form. The next step will be to complete the insertion of thousands of remaining scans of photographs and hand-copies of actual Demotic writing, a long and difficult process but one which will provide one of the most useful features of the finished dictionary.

PHILOLOGY

The Dictionary played host to two visiting Demotists this year, Professor Ursula Kaplony-Heckel of Marburg University in Germany and Bryan Muhs, a young American Demotist who now teaches at the University of Leiden. The two were in Chicago to work on the Oriental Institute's collection of Demotic ostraca and to attend the conference of the American Research Center in Egypt, where it was gratifying to see that the number of papers devoted to Demotic was large enough to merit an entire session, and this session was quite well attended and received.

While work on the Demotic Dictionary is of course primarily lexicographical in nature, our in-depth examination of words and their uses not infrequently leads to new insights into the workings of the Egyptian language on the levels of grammar and syntax. One result of this year's work has been substantial clarification of the use of the modest word *mn* "so-and-so, such-and-such." This word is a quasi-pronoun frequently found in the Hermopolis Legal Manual (a Ptolemaic-era book of instructions for drafting contracts of various types) and in magical texts that give the format for magical spells. In both types of text, the word is a substitute for a specific personal name or other noun that would be inserted by the legal or magical practitioner.

We have identified three different ways in which *mn* can be used: absolutely, with a following noun, and with a preceding noun. Used absolutely, *mn* is simply a substitute for a personal name; for example, *pꜣ mn sꜣ pꜣ mn* = "so-and-so, son of so-and-so" (*pꜣ* is the Egyptian masculine singular definite article; *sꜣ* is the word for "son"); *tꜣ mn r-ms tꜣ mn* = "(the woman) so-and-so, whom (the woman) so-and-so bore" (*tꜣ* is the feminine singular definite article; *r-ms* is a form of the verb *ms* meaning "to bear, give birth to," used in a past-tense relative clause).

When a noun follows *mn*, it means "such-and-such a ..."; for example, *pꜣ mn pꜣ ibt* means "such-and-such a month"; *pꜣ mn pꜣ tmy* means "such and such a town." Not all scribes put an article in front of *mn*; for example, in one text *mn ꜣh* is used to mean "such-and-such a field." However, whenever *mn* does have an article in front of it, it is regularly of the same gender as the noun with which *mn* is in apposition. A peculiar exception to this rule is seen in a handful of late magical texts, where *mn* has a feminine article but is in apposition to a masculine noun: *tꜣ mn pꜣ ntr* = "such-and-such a god"; *tꜣ mn n pꜣ ꜣ-shn* = "such-and-such a commission or request." Exactly why this should be is unclear to us; it may be a reflex of the very old Egyptian tendency to regard the feminine gender as also carrying the indefinite and the neuter. That would explain why we have no examples of a masculine *mn* in apposition to a feminine noun (e.g., no **pꜣ mn tꜣ shm.t* "such-and-such a woman"). But at any rate, since this mixing of genders occurs in more than one text, the use of a feminine *mn* with a masculine noun seems to be a regular and permissible construction, at least at this time and in this text genre.

Finally, *mn* can also follow a noun. This is only the case when the noun is something that can be quantified or counted; in these cases, *mn* refers to an indefinite quantity, not the thing itself. For example: *ms.t tꜣ mn* = "such-and-such amount of interest" (here the word *ms.t* "interest," is related to the verb *ms* "to bear, give birth to" we mentioned above; the idea is that the principle "gives birth to" the interest); *nkt mn* = "such-and-such amount of property"; *hꜣ mn* = "such-and-such amount of silver."

An interesting combination of these expressions is found in the Hermopolis Legal Manual, where the author has provided the form for adding the date to a contract.

The scribe who drafts a contract is supposed to write: *hsb.t mn n p3 mn ibt* “the Nth regnal year in such-and-such a month.” This shows that the author of the manual regarded regnal years (*hsb.t*) and months (*ibt*) differently; a *hsb.t* was part of an infinite countable series, but an *ibt* was one of a (limited) group that could be specified.

The peculiar use of feminine *mn* with masculine nouns we mentioned above, which appears to be limited to a particular text genre and particular time period, is only one example of the numerous regional and temporal variations in Demotic vocabulary, grammar, orthography, and usage. Another interesting example of a temporal and/or geographic variation in usage came to light this year in our work on the word *shm.t* “woman.” Aside from its regular use as a noun, the word *shm.t* is frequently used attributively, feminizing its antecedent. Normally, the word will follow its antecedent, as in the phrase *b3k.t shm.t* “female servant” or *w3h-mw shm.t* “female choachyte” (the Egyptian title *w3h-mw* literally means “water-pourer” and was the title of a low-ranking class of funerary priests called “choachytes” in Greek documents). However, the title *w3h-mw* presents a problem. The pattern *w3h-mw shm.t* is attested only in Persian-era Demotic (that is, Demotic written before the Greeks conquered Egypt in 333–332 BC), and only in the area of Thebes (modern Luxor and environs). In Ptolemaic-era Demotic texts from the Memphite area (just south of modern Cairo), the pattern is reversed: rather than *w3h-mw shm.t*, the meaning of which is absolutely clear, we get *shm.t w3h-mw*.

Precisely how this is to be understood is uncertain: Egyptian grammar would permit understanding *shm.t w3h-mw* either as “woman (and) choachyte” or as “woman (of a) choachyte.” General historical and social considerations do not provide us with a definitive answer to our dilemma. The existence of the Theban title *w3h-mw shm.t* leaves no doubt that, at least in Persian-era Thebes, a woman could be a choachyte in her own right. But we also know that in some types of Ptolemaic-era administrative texts women were referred to with reference to their husbands’ occupations (although these references used the word *rm.t* “female person” rather than *shm.t*).

However, a number of lines of argument have led us to suspect that in the case of *w3h-mw*-titles from Ptolemaic Memphis and environs, the translation “woman (and) choachyte” rather than “woman (of a) choachyte” may be preferable. In the first place, there is a fragmentary Demotic stela in the Cairo Museum, found at Giza (not far from Memphis), in which two men with the title *w3h-mw* are named, apparently as dedicators of the stela itself. Accompanying these two masculine names is the name of a woman with the title *shm.t w3h-mw*, who appears on the stela on exactly the same footing as the two men. No husband is mentioned, but the woman’s father is named, precisely as are the fathers of the two men. A *w3h-mw* and a *shm.t w3h-mw* also appear in parallel and on precisely the same footing in Papyrus Louvre 3266, a Memphite contract having to do with the shares of income flowing from choachytal services. At one point in the contract, there is a reference to the “income and the stipends and everything else that belongs to the *w3h-mw* Imhotep son of Pamon together with ... the income and the stipends and everything else that belongs to the *shm.t w3h-mw* Tanitna, daughter of Tanimu.” The most straightforward interpretation is that on the Giza stela and in P. Louvre 3266, the title *shm.t w3h-mw* is simply the female equivalent of the masculine title *w3h-mw* — that is, it is to be taken as “woman (and) choachyte.”

PHILOLOGY

If this reasoning is correct, then perhaps the other Ptolemaic documents from Memphis (primarily property conveyance contracts) that employ the pattern *šm.t wšḥ-mw* can also be taken as “woman (and) choachyite.” And finally, this may indicate that in other instances in which the pattern *šm.t* plus an occupational title occurs — and again, these are all Ptolemaic and all from the region of Memphis — we may also be entitled to translate “woman (and) title”; for example, *šm.t wḥ* may well mean “woman (and) priest,” and *šm.t nf* may even mean “woman (and) sailor.”

Up until now we have discussed only documentary texts, but of course the analysis of religious and literary texts leads to novel insights as well. One interesting discovery this year was of a new, if hardly surprising, epithet of Min, the ithyphallic god who was identified with the Greeks’ randy Pan. Both were honored in the Wadi Hammamat, where numerous Demotic and Greek dedications to the god(s) have been found. One common epithet in these graffiti was understood by the original editor of these very difficult texts as *Mn pš ḥt n pš tw*, or “Min, the foremost of the mountain.” However, the sign which was taken by the editor of these graffiti as *ḥt* “foremost” occasionally has a diagonal slash through it, which certainly requires a reading of *ḥwt* “male.” A better translation of the epithet, therefore, is “Min, the male of the mountain,” a sobriquet in perfect keeping with Min’s most prominent attribute.

Finally, one of the earliest explicit mentions in Egyptian of the dismemberment of Osiris by his brother Seth was discovered by François Gaudard, a research assistant on the dictionary. For his dissertation, Gaudard is working on P. Berlin 8278, a Demotic version of the well-known Egyptian story of the struggles between Horus and Seth, and his work has also borne rich fruit for the dictionary. The story of the destruction of Osiris’ body by his brother Seth is well known from Greek sources but is generally only alluded to in Egyptian texts. Aside from P. Berlin 8278, one of the few other texts that makes the incident explicit is the Papyrus Jumilhac, a cursive hieroglyphic papyrus from the Ptolemaic period, which refers to gathering up specific Osirian body parts, including the head, extremities, phallus, and the divine jaw, among others.

In an unfortunately broken passage, Gaudard has read the phrase [...] *pš šhw mt.t ḥt.t. r-gmz w ... [...] ḥt.t. ḥt.t.* The word *šhw* is an archaizing variant of the common Demotic verb *swḥ* “to gather” here used nominally: “the gathering.” *mt.t* means literally “word,” but is used regularly to form abstract compounds. The word *ḥt* is a noun meaning “strip” and appears in the best-known Demotic magical text in the context of a strip of cloth. But here, it is compounded with the word *ḥt.t* “body, flesh,” and so the entire compound *mt.t-ḥt.t*, literally means “strip-of-flesh-stuff.” This is followed by a relative clause, “which was found [...] ḥt.t. ḥt.t.” as well as mention of Seth’s being “cheated” by the embalming of Osiris. All in all, we seem to have an unusually clear reference to the sparagmos — the rending apart — of Osiris’ body.

As these examples show, the range and variety of information about late Egyptian society and culture deriving from our lexicographic research has proven to be one of the most interesting and fruitful aspects of our work. We hope to share further results with the interested lay and professional public in the very near future!



RESEARCH

Overleaf. Conservation staff carefully placing Egyptian artifacts into their permanent shelving units in climate-controlled new wing. Photograph by Jean Grant

INDIVIDUAL RESEARCH

Richard H. Beal

Richard H. Beal spent much of his time checking references and otherwise preparing the first fascicle of the Hittite Dictionary's Š volume for publication. Beal has been reading entries in this volume to Professor Güterbock, now almost blind, for his invaluable comments, gleaned from some 70 years of experience reading Hittite. His comments are then noted. Minor things are entered directly into the computer manuscript, while Beal takes substantial matters to Professor Hoffner to be hammered out. Meanwhile, he has also been doing a certain amount of copy editing on the texts that he has been reading to Professor Güterbock; this will make the job quicker when these dictionary articles return to his desk. Although some long and difficult Š-words remain to be written and so have not been discussed, most of the words for this volume have now been written and approved by Professor Güterbock. In and around doing this Beal has finished writing a first draft of the long and interesting word *šiu-* "god/goddess." In addition Beal has been making transliterations for the dictionary's files of a section of the newly published volume 41 of the series *Keilschrifttexte aus Boghazköi* that contains questions to the gods and the gods' answers.

Beal traveled to California to attend the Second Magic in Antiquity Conference. His lecture, "Dividing a God," was based on his research for the Hittite dictionary draft of the verb *šarra-*. It explained that, with *šarra-* properly understood, the way to have two separate cult centers for the same deity was to have that deity divide his or her divinity and to have that allomorph of the original physically moved and/or coaxed through ritual actions into the new temple. Closer to home, in February he gave a lecture, "New Discoveries in Hittite Archaeology," to the South Suburban Archaeological Society in Homewood, Illinois. An article, "Hittite POWs," was completed for the *Encyclopedia of POWs and Internment*. He also completed a review of Trevor Bryce's very useful book *The Kingdom of the Hittites* for *The Historian*. He again spent part of his vacation reading Assyrian and Babylonian tablets in the British Museum to assist his wife, JoAnn Scurlock, with her works on *Magico-Medical Means of Expelling Ghosts in Ancient Mesopotamia* and on *The Lost Medicine of Ancient Mesopotamia*. They also spent down time photographing the Middle Eastern sections of the British Museum and the Islamic fantasy rooms of the home of Victorian painter Lord Leighton. Beal and Scurlock gave an illustrated talk, "Sultans and Seths, Rajputs and Rabaris," to the Oak Park Council on International Affairs, a talk that was repeated in Kansas City. While in Missouri, they journeyed to Lonejack to photograph the collections of the Nance Museum of the ethnography of Saudi Arabia and surrounding countries. They have also given specially tailored slide presentations on various aspects of the Islamic world to a number of college classes and high schools in the Chicago area.

Beal and Scurlock also spent part of their vacation visiting many magnificent molded mud mosques in Mali. The intention was to extend their ever-growing slide library of Islamic civilization. Djenné's mosque and old town were, of course, the high point of the trip, but every town and village has a uniquely shaped locally con-

RESEARCH

structed smaller version. The trip also included three days and nights sleeping atop very hard sacks of millet on a cargo boat on the Niger River to Timbuktu. An overnight trip to visit the old multi-towered mosque in Bobo Diolosso in Burkina Faso completed this phase of the trip. While in the area they also decided to visit the oasis town of Oualata in Mauritania, where women paint geometric designs on the house walls. Four days of photographing in the Louvre's Near Eastern galleries rounded out the trip.

Robert D. Biggs

Robert D. Biggs has worked in various Babylonian literary genres in the past year. He spent part of summer 1998 at the British Museum in London working on Babylonian prophecy texts. His serving on a Ph.D. dissertation committee at the University of Copenhagen provided the incentive to do further study of Babylonian liver omen texts, and the dissertation defense gave him occasion to spend a few days of the Christmas season in Copenhagen. He continues to work on Mesopotamian medical texts.

John A. Brinkman

John A. Brinkman wrote a short encyclopedia article on the Scythians. He collaborated with John A. Larson on an article discussing a missing fragment of the Khorsabad Kinglist (which appeared in the June issue of *NABU*). He wrote fourteen biographical entries for *The Prosopography of the Neo-Assyrian Empire*, volume 1, part 2; Daniel Nevez, Shelley Luppert-Barnard, and John Nielsen, graduate students in the Mesopotamian historiography seminar, wrote an additional seventeen entries. He collated tablets in the Harvard Semitic Museum (two brief visits in January and March) and continued cataloging the Kassite archives in the University Museum, Philadelphia (May). This year's research theme in the historiography seminar was the origin and early development of extended family groups in Babylonia, particularly in the Late Bronze and Early Iron Ages (ca. 1600–600 BC).

Peter F. Dorman

This spring **Peter F. Dorman** finished writing a monograph that has been a number of years in preparation, entitled *Faces in Clay: Technique, Imagery, and Allusion in a Corpus of Ceramic Sculpture from Ancient Egypt*. To be published in the series *Münchener ägyptologische Studien*, this study establishes a typology for human-headed canopic jar lids made of terra-cotta and, on the basis of stylistic similarities to contemporary sculpture in stone, explores the relationship between the workshops

of potters, sculptors, and painters in ancient Egypt. Advocating the recognition of ceramic as one of the standard media of monumental sculpture in pharaonic times, the volume contains an illustrated catalog of almost one hundred canopic lids from museums in the United States, Europe, and Egypt. It also examines the religious symbolism of the potter's wheel in the creation of mankind and in the self-regeneration of the sun god in the early hours of dawn.

In April, Dorman organized a scholarly workshop, co-sponsored with Johns Hopkins University, on *Thebes and the Rise of Empire: The Middle and New Kingdoms*, at which six papers were given on chronological, archaeological, and art-historical aspects of national reunification at critical times of incipient empire. Envisioned as the first of a series of annual symposia devoted to the Theban region, where a great deal of fieldwork is conducted every year, the workshop was scheduled at the end of the annual meeting of the American Research Center in Egypt, held this year in Chicago, and was attended by an audience of fifty-five members. In May, as part of a series on Women in the Ancient World, Dorman also delivered a public lecture on queen Hatshepsut for the California Museum of Ancient Art, examining her gradual rise to kingly power and the possible motives for her delayed posthumous proscription.

Walter Farber

Walter Farber continued to work on his major project, the *Lamashtu* text edition. In addition, he finished two sizeable festschrift articles on some Old Akkadian and Old Babylonian texts from collections in Germany (one of them co-authored with Gertrud Farber), as well as a number of shorter notes and book reviews. Work in progress includes one more festschrift contribution (they seem to never end) and the publication of more tablets from smaller German collections. While preparing these manuscripts, he continued to refine his technique of using a computer scan to produce first-rate printable copies of cuneiform texts directly from the pencil originals.

On a non-Assyriological note, Walter was invited to contribute to the German-American Salon at the World Exposition of Philately, IBRA, in Nuremberg/Germany, where he exhibited material from his collection of German post-World War II postal history. He also co-authored a small book on the military and postal history of the Luxembourg occupation of an area of Germany after World War II, an episode not well known even among German historians of the time. This was published in Germany in the spring.

McGuire Gibson

This has been a very busy year for **McGuire Gibson**. Besides his research on Nippur, he has continued to direct the Diyala Objects Project. He has also begun planning for a new excavation in Syria, scheduled to begin in fall 1999. A prelimi-

RESEARCH

nary visit to Syria in September 1998 allowed a side trip to Beirut, which he had not seen since 1975. The destruction caused by the civil war was visible on many buildings, as well as in the acres of empty space where damaged buildings have been demolished to prepare for new construction. The atmosphere in the city is optimistic, and construction that has already been done is most impressive. Six months later, in March, he returned to Damascus as a guest speaker for the United States Information Service. He delivered lectures at the Directorate General of Antiquities, the University of Damascus, and the USIS. He also visited potential excavation sites and held discussions with the Director of Antiquities and the Minister of Culture.

During the past year, Gibson participated in three international conferences. In one at Rutgers on *Art, Antiquity, and the Law: Preserving our Global Cultural Heritage*, he reported on the state of antiquities and cultural heritage in the Near East in general and Iraq in particular. At another conference on *Iraq: Its History, People, and Politics* at Villanova University, he spoke on the ancient history and archaeology of Mesopotamia. In a symposium on ancient palaces, held in Copenhagen, he discussed "Paper Trails" (or rather, "clay trails") in Mesopotamian palaces. During the year, he also gave lectures at the McClung Museum in Knoxville, Tennessee, at the University of Pennsylvania, and he also addressed several audiences in Chicago.

Gibson was recently re-elected to the Executive Committee of the Council of American Overseas Research Centers and serves on the board of the American Institute for Yemeni Studies.

Harry A. Hoffner, Jr.

Once again, in 1998/99 **Harry A. Hoffner, Jr.**, used the majority of his research time for the directing and editing of the *Hittite Dictionary of the Oriental Institute of the University of Chicago*. In addition to teaching and committee work, he also traveled, lectured, and authored or edited several articles and books.

In summer 1998 in accordance with university guidelines he gave a two year advance notice of his intention to retire from active faculty status effective summer 2000. The Oriental Institute and the Department of Near Eastern Languages and Civilizations with authorization from the University appointed a search committee chaired by Walter Farber and on which Hoffner served as a member to identify the best candidate for the faculty position in Hittitology. The job description also includes the on-site direction of the Hittite Dictionary Project. Hoffner therefore used 1998/99 as the first of two years during which he will make the smoothest possible transition in the administrative leadership of the Hittite Dictionary Project as well as the academic preparation of current graduate student majors in Hittitology.

Publications from his hand that appeared in 1998/99 include "Agricultural Perspectives on Hittite Laws §§167–169," in *Acts of the IIIrd International Congress of Hittitology* (Çorum, 16–22 September, 1996), edited by S. Alp and A. Süel (Ankara: Grafik, Teknik Hazırlık Uyum Ajansı, 1998), pp. 319–30; "From the Disciplines of a Dictionary Editor," in *Journal of Cuneiform Studies* 50 (1998), pp. 35–44; *Hittite Myths* (Second Revised Edition; Writings from the Ancient World 2; At-

lanta: Scholars Press, 1998); "Hurrian Civilization from a Hittite Perspective," in *Urkesch and the Hurrians: Studies in Honor of Lloyd Cotsen*, edited by G. Buccellati et al. (Malibu: Undena, 1998), pp. 167–200; "Nachlass, bei den Hethitern," in *Reallexikon der Assyriologie*, Band 9, edited by E. Ebeling et al. (Berlin: Walter de Gruyter, 1998); "Namen. B. Bei den Hethitern," in *Reallexikon der Assyriologie*, Band 9, edited by E. Ebeling et al. (Berlin: Walter de Gruyter, 1998), pp. 116 ff.; and "On the Denominative Verb *arāwe-*," in *Mír Curad: Studies in Honor of Calvert Watkins*, edited by J. Jasanoff et al. (Innsbruck: Institut für Sprachwissenschaft der Universität Innsbruck, 1998), pp. 275–84.

Work accepted and forthcoming includes "Hittite Archives" in *The Archaeology of Anatolia: An Encyclopedia*, edited by G. K. Sams (Ankara: Bilkent University, 1999); "The Royal Cult in Hatti," in a volume on *King and Cult in the Ancient Near East*, growing out of a paper delivered at a conference in April 1998 at the Center for Judaic Studies in Philadelphia; and the jointly edited volume *Recent Developments in Hittite Archaeology and History*, edited by H. G. Güterbock, H. A. Hoffner, and K. A. Yener (Winona Lake: Eisenbrauns, 1999).

Research in progress, but not yet submitted, includes the next volume of the *Hittite Dictionary*, containing the beginning of the Š words.

Hoffner was invited to deliver a public lecture, *Daily Life in Ancient Hatti*, at the annual meeting of the Midwest Branch of the American Oriental Society in Cincinnati, Ohio, 14 February 1999. A slightly modified form of this lecture will appear in a volume on the theme of *Daily Life in the Ancient Near East* to be edited by M. Chavalas, R. Averbeck, and D. Weisberg and published by CDL Press. Hoffner also continued to function as a member of the editorial board of the Society of Biblical Literature's Writings from the Ancient World series and as Hittitological consultant for the project *Scripture in Context*, edited by W. W. Hallo and Lawson Younger, to be published by E. J. Brill in Leiden, The Netherlands. As a member of the editorial board of the Writings from the Ancient World series, he attended the board's annual meeting in Orlando, Florida on 19 November 1998.

Thomas A. Holland

Thomas A. Holland continued his research for the first part of a final publication of the Tell Es-Sweyhat archaeological expedition to Syria during this academic year with the result that most of this report is now nearly ready for presentation and publication in a forthcoming Oriental Institute Publications volume. As reported last year, much work was needed to clarify the Hellenistic and Roman periods at Sweyhat. A final assessment of the Roman remains from Area I, Trenches IA1 and IA2, presented in the Archaeology section of this year's report (see separate report), has greatly increased our understanding of the Roman remains that overlaid the third millennium BC wall painting building in Operation 5, which was discussed in last year's *Annual Report*.

Apart from the continuing research for the final Tell Es-Sweyhat reports and the editing of other Oriental Institute publication manuscripts, Holland submitted an

RESEARCH

article entitled "Third Millennium Wall Paintings at Tell Es-Sweyhat, Syria" for inclusion in a festschrift volume that will honor the sixty-fifth birthday of Professor Dr. Winfried Orthmann on 16 August 2000.

On behalf of the Publications Department, the writer expresses his appreciation to all those people at the Oriental Institute and outside who have helped in various ways to facilitate the preparation of the scholarly volumes published each year. Also, on behalf of the Sweyhat Expedition to Syria, he would especially like to again thank Margaret and Jim Foorman for their support of this ongoing research project.

Janet H. Johnson

Janet H. Johnson had a leave of absence from her teaching responsibilities during the last academic year and very much enjoyed being able to work extensively on the Demotic Dictionary Project. She gave a report on the project at the International Demotic Conference held in Copenhagen in August 1999. For a report on the Demotic Dictionary, see the section on Philology. She was invited to speak on *Women's Rights in Ancient Egypt* as the tenth annual W. Kendrick Pritchett lecture for the Graduate Group in Ancient History and Mediterranean Archaeology, University of California, Berkeley, in November 1998, and as the 1999 William F. Albright Lecture at Johns Hopkins University in April 1999. Her article "Women, Wealth, and Work in Egyptian Society of the Ptolemaic Period" appeared in the *Studies Dedicated to the Memory of Jan Quaegebeur* and her articles on the history and textual sources of Late period Egypt appeared in the new *Encyclopedia of the Archaeology of Ancient Egypt*. She continued to serve on the Board of Governors of the American Research Center in Egypt and as Chairman of the Committee for the Annual Egyptological Bibliography. She held preliminary meetings with Terry Wilfong and Janet Richards, from the University of Michigan, concerning the implementation of the Mellon Foundation grant for Less Commonly Taught Languages, under which they will develop an annotated electronic reading book for Middle Egyptian. Although she enjoyed having the opportunity to work intensively on the Demotic Dictionary, she missed teaching and looks forward to the resumption of classes in fall 1999.

W. Raymond Johnson

This year marked **W. Raymond Johnson's** twentieth season working for the Epigraphic Survey and his second full year as Field Director. In addition to his Survey duties (see separate report), Ray continued to pursue his personal research on stylistic changes in Egyptian art and on the theological and political motivations behind those changes. Most recently he contributed a chapter on this topic to the catalogue of the Museum of Fine Arts, Boston exhibition: *Pharaohs of the Sun: Akhenaten*,

Nefertiti, and Tutankhamun, entitled *The Setting: History, Religion, and Art*, which has just been published. In it he examines the phenomenon of stylistic change through Egyptian history leading up to, and including, the Amarna period. This exhibition will travel to the Art Institute of Chicago in July, 2000.

Ray has been following a personal research and documentation program designed to document unrecorded, fragmentary sculpture and relief work from the late Eighteenth Dynasty for analysis and publication. His study, "The *Nfrw*-Collar Reconsidered," in *Gold of Praise: Studies on Ancient Egypt in Honor of Edward F. Wente*, SAOC 58 (Chicago: forthcoming, 1999), at the proof stage now, focuses on colossal sculpture fragments of Amenhotep III and Queen Tiye from Medinet Habu that feature unusual iconography which proclaims their deified state. In related work, as Project Director of the Memphis "Amenhotep III Reused Block Project" for the Egypt Exploration Society, London, Survey of Memphis Expedition, he supervised a fourth short season of documentation work in November at the Ramesses II small Ptah temple in ancient Memphis, focusing on reused limestone blocks of Nebmaatre Amenhotep III exposed there. He finished collating the drawings of the sixty-two blocks and fragments identified so far with artist Will Schenck, and will return next November to study the architectural fragments. The material, quarried by Ramesses II for reuse in his Ptah shrine and presently in an active state of decay, was originally part of a bark sanctuary in Amenhotep III's great Ptah temple complex "Nebmaatre-United-with-Ptah," and will be published as a separate volume in the Egypt Exploration Society's *Survey of Memphis* series.

Carol Meyer

In addition to directing the archaeological excavations at Bir Umm Fawakhir (see separate article) **Carol Meyer** gave several presentations on the site. In November she spoke on "The Gold-Miners of Bir Umm Fawakhir" at the Byzantine Studies Conference in Lexington, Kentucky, in April on "The Bir Umm Fawakhir 1999 Excavations" at the American Research Center in Egypt annual meeting in Chicago, and in May on "A Byzantine Gold-Mining Town: Bir Umm Fawakhir" at the Late Antique and Byzantine Studies workshop at the University of Chicago. Several publications have appeared, including "Gold Miners and Mining at Bir Umm Fawakhir" in *Social Approaches to an Industrial Past* (London: Routledge); "Three Seasons at Bir Umm Fawakhir," with Lisa Heidorn, in *Life on the Fringe* (Leiden: CNWS); two articles in the *Encyclopedia of the Archaeology of Ancient Egypt* (London: Routledge); and "A Baboon Amulet from Ishchali," in *Ancient Egypt, the Aegean, and the Near East: Studies in Honour of Martha Rhoads Bell*, Volume 1, edited by J. Phillips (San Antonio: Van Siclen Books, 1998).

Erica Reiner

Erica Reiner served as Visiting Professor at Brown University in Providence, Rhode Island during the second semester of 1998/99. She taught two courses: Introduction to Akkadian, and a seminar on Mesopotamian Literature.

Her book *Babylonian Planetary Omens*, Part 3, written with the collaboration of David Pingree, appeared in fall 1998. Her contributions to the festschriften for Rykle Borger and for Oswald Loretz have now appeared; those to other festschriften are still in press.

Robert K. Ritner

Robert K. Ritner taught six courses on topics in Late Egyptian, Hieratic, Demotic, and Coptic Dialects in addition to an experimental undergraduate course on Egyptian religion that attracted some 50 students. During the Oriental Institute's workshop on *Introducing Ancient Egypt* on 14 November, he provided an illustrated lecture examining "Egyptian Religion and Kingship." On 24 November, he spoke to elementary schools in Manassas, Virginia on Egyptian history and culture. On 27 February, he served as guest speaker for the symposium *Africa's Egypt: New Perspectives on an Ancient Civilization*, sponsored by the Institute of Egyptian Art and Archaeology of The University of Memphis and the Pink Palace Museum. In the lecture, "Never Quiet on the Western Front: Libya and Ancient Egypt," he surveyed the complex, but little studied, evidence for interactions between Libyan pastoralists and their settled neighbors from Neolithic to Hellenistic times.

Beyond teaching and lecture duties, Ritner continued to serve as an editor for the series *Writings from the Ancient World*, acted as editorial consultant for the University of Oklahoma Press and the American Journal of Archaeology, and was a Fellowship Committee member for the American Research Center in Egypt (ARCE). Also for ARCE, he was responsible for the organization of all presentations on pre-Islamic Egypt during the 1999 annual meeting held in Chicago from 23 to 25 April. This ancient section, which had included only 62 papers in 1995 and 72 in 1998, has now grown to 100 lectures in an unprecedented 16 panels. Following the ARCE meetings, Ritner was interviewed as an expert witness for the Commission of Chicago Landmarks, contributing to the successful grant of landmark status to the Egyptian Revival Reebie Brothers Storage Warehouse (2325–33 North Clark Street).

Entrusted with the design of the case on "Magic and Medicine" in the new Grimshaw Egyptian Gallery, Ritner selected objects whose symbolic interrelationships are the focus of the display and labels. In contrast to the minimalist approach adopted elsewhere, this case directs the viewer to the thematic links between developing iconography and ritual function.

His publications during the year include "Egypt under Roman Rule: the Legacy of Ancient Egypt," in the *Cambridge History of Egypt*, edited by Carl Petry; "The Wives of Horus and the Philinna Papyrus (PGM XX)," published in *Egyptian Religion: The Last Thousand Years. Studies Dedicated to the Memory of Jan*

Quaeghebeur, edited by Willy Clarysse, Antoon Schoors, and Harco Willems (Orientalia Lovaniensia Analecta 84; Leuven: Peeters, 1998); and a review of *Magic in Ancient Egypt*, by Geraldine Pinch, published in the *Journal of Near Eastern Studies*. He is now working toward the completion of his announced volume of translations comprising the primary inscriptions from Egypt's Third Intermediate Period. In addition, he is preparing new translations of Late period hieroglyphic and Demotic literary texts for a new edition of *The Literature of Ancient Egypt*, edited by William K. Simpson for Yale University Press.

Oğuz Soysal

In 1998/99 Oğuz Soysal continued his work on the Chicago Hittite Dictionary Project. He has spent most of his time writing articles on words beginning with “š” (mostly šu-, and a few ša- words).

Aside from this, his research activities have continued to focus on Hittite language, history, and culture. Two articles dealing with Hittite oracular and festival texts have been published in *Archivum Anatolicum* 3 (Turkey, 1998) pp. 301–339 and in *Journal of Cuneiform Studies* 50 (1998) pp. 59–65. He currently has other works in press in the journals *Hethitica* 14 (Belgium, 1999), *Kratylos* 44 (Germany, 1999), *Zeitschrift für Assyriologie* 90 (Germany, 2000), *Archivum Anatolicum* 4 (Turkey, 2000), and in a German festschrift (1999).

In addition to these activities he has also been preparing since January 1996 a Hattian word list based on texts in the Hattian language from Boğazköy (Hattian-Hittite bilinguals, Hattian recitations, Hittite rituals and festivals with Hattian elements, etc.). The list in question currently consists of 10,000 computer-stored entries (words and word complexes; 100% of published material) on 450 pages and is still in progress.

In 1998 he received an official invitation from the leaders of the Ortaköy excavation (in Çorum, Turkey) to work jointly with them on the epigraphic finds. The work on the Ortaköy epigraphic finds was begun in 1990 by a Turkish team led by Aygül Süel, excavator of Ortaköy and member of Ankara University. Soysal joined this team in 1998, and since then he has been contributing to the studies on the documents in Hattian within his personal project, Ortaköy-Sapinuwa Epigraphical Research (OSER). This project has been supported by the American Research Institute in Turkey in 1999 with a research fellowship. The work in 1999 was conducted during April and May. He spent the month of April with Aygül Süel in Ankara to select texts for further research. In May, accompanied by Yasemin Arıkan-Soysal and Esmâ Reyhan (both are members of Ankara University), the team went to Çorum and began taking pictures of the selected original tablets (primarily the Hattian and vocabulary texts), which are deposited at the Museum of Çorum. During this work more than ten small fragments have been identified as joins, and glued together in order to gain larger and more complete texts. They now total fifty fragments, most belonging to three different foundation rituals written as bilinguals in Hattian and Hittite, that are already known from the Boğazköy archives. There are also a few

RESEARCH

very important vocabulary texts. With the permission of Aygül Süel, the pictures of these Hattian and vocabulary fragments were brought to Chicago. This makes intensive work on the epigraphic material of Ortaköy possible in Soysal's workplace at the Oriental Institute, where he is able to use the rich archival files collection of the *Chicago Hittite Dictionary*. The Ankara-Chicago cooperation is expected to be very fruitful for Hittite lexical studies. Indeed, the results that this cooperation has achieved to date are encouraging. The Hattian-Hittite bilingual texts and Sumerian-Akkadian-Hittite vocabulary texts have revealed many lexical items that remained unknown to date. It is fortunate that there is the great opportunity to consult in the Ortaköy epigraphical research two lexical projects at the Oriental Institute – the *Chicago Hittite Dictionary* and the *Materials for the Sumerian Lexicon*. Their support is very important for utilizing and commenting on the epigraphic material from Ortaköy. As part of the work for 1999, Oğuz Soysal and Aygül Süel are now preparing three joint articles for publication, in which they will report the first results of the studies on the Ortaköy tablets, in order to make them accessible to the community of scholars in the humanities. The tentative titles are: *A Vocabulary Text from Ortaköy*, *The Hattian-Hittite Foundation Rituals from Ortaköy (I)*, and *Ortaköy'de Bulunmuş Hattice-Hittite İnşa Ritüelleri (I)* (Turkish version of the second).

Matthew W. Stolper

Matthew W. Stolper spent part of September 1998 at the Vorderasiatisches Museum in Berlin reading fragments of late Achaemenid legal tablets excavated by the German expedition to Babylon in 1913. The fragments belong to an archive that promises exceptional information on the political career and economic connections of a Babylonian governor in the Persian provincial administration at the end of the fifth century BC. He will continue work on them in September 1999. His interim account of the Berlin texts will be published in the proceedings of the Second International Colloquium of the *Deutsche Orient-Gesellschaft*, devoted to the history of Babylon. He also gave a paper on these texts and two other fifth century archives at a conference on Interdependency of Institutions and Private Entrepreneurs, one of a series of international symposia at the Middle East Studies program of Leiden University.

In "Lèse Majesté," a communication at the annual meeting of the American Oriental Society, Stolper suggested that accusations of speech against the Persian king found in a few early Achaemenid Babylonian legal texts are not flickers of resistance to Persian rule, but instances of a long-standing political dynamic (kings promoted competition to gather information), an established political institution (kings imposed loyalty oaths that required subjects to denounce each other), and a long-standing rhetorical trope (kings described themselves as just arbiters of conflict).

In "Lurindu the Maiden, Bel-ittannu the Dreamer and Artaritassu the King," submitted to a festschrift, Stolper identified a scribe who wrote records of day-to-day legal business as well as astrological texts and records of dreams, but who could

not spell the king's name, Artaxerxes, except in a hyper-learned way. An article for another festschrift presents three stray Middle Elamite administrative texts that came from Tall-i Malyan (ancient Anshan).

Stolper prepared a sketch of Elamite grammar for the *Cambridge Encyclopedia of the World's Ancient Languages*, an entry on *ganzabara* (an Old Iranian word for "treasurer," found as a loanword in Babylonian, Elamite, Hebrew, Aramaic, and other languages of the Achaemenid Empire and its successors) for the *Encyclopedia Iranica*, and a few shorter encyclopedia entries, notes on late Babylonian texts, and book reviews.

Stolper also made high-resolution scans of about 900 photographs of the Oriental Institute excavations at Persepolis. They have since been made available on the Oriental Institute website. The photographs of inscriptions will be linked to the on-line edition of the texts of the Achaemenid Royal Inscriptions project (ARI). Unpublished excavation photographs of the inscriptions are to be scanned and linked to the texts as well.

The historical journal *Annales* will publish Stolper's review article on *The Magisterial History of the Achaemenid Empire* by Pierre Briant, whom Stolper presented to President Sonnenschein for an honorary Doctorate of Humane Letters at the June 1999 Convocation of the University.

Claudia E. Suter

Claudia E. Suter continued her work as the coordinator of the Diyala Project. In January, her review of Elena Rova's study of Uruk period cylinder seals appeared in the *Journal of Near Eastern Studies* 58, and in May, her review article of Dietz Otto Edzard's edition of the Lagaš II Royal Inscriptions including Gudea's Cylinders (RIM 3/1) appeared in the *Journal of Cuneiform Studies* 50, dedicated to Hans Gustav Güterbock. Her book entitled *Gudea's Temple Building: The Representation of an Early Mesopotamian Ruler in Text and Image* will be published in the series *Cuneiform Monographs* this summer. Still in press are a biography of Henriette Groenewegen-Frankfort for the anthology *Women in Archaeology: The Classical World and the Ancient Near East*, edited by Getzel M. Cohen and Martha Sharp Joukowsky, and the entry on the Oriental Institute Museum for the *Neue Kleine Pauly*. Several reviews, for the *Journal of Near Eastern Studies* and *Aula Orientalis*, on books about ancient Near Eastern seals, and an article on the Hittite stamp seal from Megiddo (in the Oriental Institute collections) for a festschrift are completed or near completion.

After twelve very instructive and productive years in the United States, eight at the University of Pennsylvania and four at the Oriental Institute, Claudia is looking forward to her return to Europe. She was accepted as a participant in the course entitled *Museum und Arbeit* offered by the International Summer Academy of Museology in Austria and will participate in the excavations of the Universities of Warsaw and Vienna at Tell Arbit in the Habur Region of Syria in September/October.

Emily Teeter

Most of **Emily Teeter's** time was consumed by the installation of the Oriental Institute Museum's new Grimshaw Egyptian Gallery. She was called upon to give numerous lectures about the installation and on the mechanics and theory of museum exhibitions. Among the talks were the Harper Lectures, sponsored by the University of Chicago Alumni Society in Seattle and Portland. To prepare our own docents for the new gallery, she wrote a new training handbook and presented several lectures and gallery tours. She served as a consultant for the exhibit *Women of the Nile* presented at the Rosicrucian Egyptian Museum in San Jose, and she was the keynote speaker at a teacher's training institute at the University of Washington in conjunction with the Seattle Art Museum's presentation of the exhibit "Searching for Ancient Egypt" circulated by the University Museum, Pennsylvania. She returned to Seattle later in the year to participate on a panel discussion of the African-ness of ancient Egyptian culture. She also spoke at the Northern California chapter of the American Research Center in Egypt, discussing her research on baked clay figurines from Medinet Habu. In April, Emily served as the overall coordinator of the annual American Research Center in Egypt meetings which were held in Chicago with record-breaking attendance (over 350 people).

Emily joined Franck Goddio's team in the Eastern Harbor of Alexandria. Using sonar and underwater GPS surveying techniques, the joint French-Egyptian team's findings have significantly altered the traditionally accepted map based upon Strabo's *Geography*. Emily joined the project to help identify and date architectural remains and sculpture retrieved from the ruins of the Ptolemaic and Roman city.

Publications for the year include *Egypt and the Egyptians* (co-authored with Douglas Brewer); entries in Microsoft's *Encarta Encyclopedia* and in the *Encyclopedia of the Archaeology of Ancient Egypt*, edited by K. Bard; as well as numerous magazine articles about the new Egyptian Gallery. Now that the gallery is essentially complete, Emily has resumed work on the manuscripts *Egyptian Art in the Collection of the Oriental Institute* (funded by the Women's Board of the University) and the second volume of the ongoing Medinet Habu publication series, dealing with baked clay and faience sculpture. She continued to work with the Oriental Institute Publications Office on the finalization of a festschrift for Professor Edward F. Wente. Travel included a tour to Yemen and Oman and a real vacation in Europe.

David Testen

In addition to assisting the editor of the *Chicago Assyrian Dictionary* in the compiling and editing of the P volume, **David Testen** taught *Introduction to Comparative Semitic* in the Department of Near Eastern Languages and Civilizations program during the Winter Quarter. He continued his research into the development of the phonological and morphological systems of the Semitic languages in papers delivered at Stanford University ("Assimilation and Allophony within the Uvular Series," at the Thirteenth Arabic Linguistics Symposium), at Ohio State ("Early Arabic Dialectology: Gleanings from the Qur'an"), and in Baltimore ("Some Semitic

Stems Owing Their Biconsonantality to Laryngeal Loss,” at the Twenty-seventh North American Conference on Afro-Asiatic Linguistics, and “Conjugating the ‘Prefixed Stative’ Verbs of Akkadian,” at the 209th Meeting of the American Oriental Society). He also presented “Traces of a Pre-Ossetian Nominal Suffix Preserved in Early Loanwords” at the first Chicago Conference on Caucasia, held at the University of Chicago.

Testen’s monograph *Parallels in Semitic Linguistics: The Development of Arabic la- and Related Semitic Particles* was published by E. J. Brill. Other publications that appeared over the course of the 1998/99 academic year are “Modern South Arabian ‘nine’” (*Bulletin of the School of Oriental and African Studies*), “Semitic Terms for ‘myrtle’: A Study in Covert Cognates” (*Journal of Near Eastern Studies*), “The Derivational Role of the Semitic N-Stem” (*Zeitschrift für Assyriologie*), “Morphological Observations on the Stems of the Semitic ‘nota accusativi’” (*Archiv für Orientforschung*), “The Phoenician Direct-Object Marker in the Inscription of Yhwmlk” (*Ugarit-Forschungen*), “Arabic Evidence for the Formation of the Verbal Noun of the Semitic Gt-Stem” (*Journal of Semitic Studies*), and “Literary Arabic and Early Hijazi: Contrasts in the Marking of Definiteness,” in *Perspectives on Arabic Linguistics XI*, edited by Elabbas Benmamoun, Mushira Eid, and Niloofar Haeri (John Benjamins). Articles are also forthcoming in *Perspectives on Arabic Linguistics XII*, the *Journal of Near Eastern Studies*, and the Celtic journal *Ériu*.

Steve Vinson

In the past year, aside from continuing work on the Demotic Dictionary Project, **Steve Vinson** published his revised dissertation, *The Nile Boatman at Work*, which appeared in fall 1998 as vol. 48 of the Egyptological series *Münchener ägyptologische Studien*. Vinson spoke at the Ständige Ägyptologenkonferenz in Hamburg in July 1998 on the description of Egyptian boat construction in Herodotus II, 96; a revised version of this talk was published along with most other papers presented at the conference in *Studien zur altägyptischen Kultur* 26. In the fall and winter, Vinson offered another round of *Hieroglyphs by Mail* to adult education students at the Oriental Institute, ably assisted by Egyptology graduate students Nicole Hansen and Thomas Dousa. Vinson also taught *The Ancient Mariners*, a course on ancient ships and seafaring, through the Museum Education Office in two formats: in-person lectures to a group of ten and over the World-Wide Web to a further group of twenty-five, including students in Belgium and England as well as in the United States.

This fall Steve Vinson spoke at the Conference of the American Research Center in Egypt on the discovery and preliminary interpretation of a Roman shipwreck at Alexandria, discovered in 1998 by a French team led by Franck Goddio. Vinson also appeared in the Discovery Channel documentary *Cleopatra’s Palace: In Search of a Legend* discussing the wreck, its construction, and its historical importance. Finally, Vinson was awarded a travel and research fellowship from the American Research Center in Egypt for the copying and decipherment of Demotic

RESEARCH

graffiti at the Ptolemaic temple at Deir el-Medina, Luxor, a project which he hopes to undertake in summer 2000.

This was Vinson's third and last year as Research Associate on the Demotic Dictionary Project. This fall, he will be moving to Eugene, Oregon to serve for one year as a visiting assistant professor of ancient history at the University of Oregon.

Edward F. Wente

During 1998/99 **Edward F. Wente** completed his revisions of the Late Egyptian Stories for a new and enlarged edition of *The Literature of Ancient Egypt*, edited by William Kelly Simpson. In addition, he has submitted to the editor new translations of several texts that will be included in this literature volume: some Coffin Text spells of literary interest, the Israel Stela of Merenptah, several penitential hymns from the Ramesside village of Deir el-Medina, and the Myth of the Heavenly Cow, which is the oldest extended mythical narrative surviving from ancient Egypt. Although preserved only in several post-Amarna tombs, including one of Tutankhamun's shrines and Seti I's famous tomb in the Valley of the Kings, the myth was probably composed earlier in the Middle Kingdom. Aside from the narrative and etiological statements that permeate much of the myth, the Heavenly Cow also contains directions for its practical use by non-royalty. It seems that in the New Kingdom the myth and instructions for its use were quite mechanically appropriated for the pharaoh's afterlife without eliminating non-royal aspects of the text.

Wente continues with the task of reviewing Robert Ritner's translations of an extensive corpus of Third Intermediate Period texts to be published in the Society of Biblical Literature series *Writings from the Ancient World*. During his retirement he has still been involved in evaluating manuscripts submitted for publication to the *Journal of Near Eastern Studies*, to which he also contributes an occasional book review.

Donald Whitcomb

Donald Whitcomb initiated a new research project in Syria, the Hadir Qinnasrin excavations (see separate report). This is an international venture with participation of the Syrian directorate general and the Université de Paris IV (Sorbonne). This first season included only a brief survey and about 10 days of excavation. Nevertheless, the results were exactly as predicted and even may boast of new evidence for tribal settlement in the early Islamic (and possibly pre-Islamic) periods. At the end of the season, Pierre-Marie Blanc of the Institut français d'archéologie du Proche-Orient (IFAPO) gave the team an exhaustive tour of the Byzantine and Islamic remains at Bosra.

In October Don returned to Jordan for a sort of busman's holiday, to assist the Belgian excavations at Lehun. He had spent some time digging a country mosque about ten years ago and was pleased to find some of his boys, now grown men, re-

membered that experience. This time he was teamed with Johnny De Meulenmeester, a professional excavator who works in Belgium, Luxembourg, and Spain on medieval (and occasionally Islamic) sites. With only about eleven days for digging, they revealed an Ottoman period farmstead that had more formal antecedents as an early Islamic *qasr* and very probably a Nabataean caravanserai. The stratigraphy was very strange, with 3 m in some rooms of Ottoman occupation while in the next room only 50 cm of Islamic before good Nabataean materials.

When this dig ended, Don met the indefatigable Bill Harms, of the University News Office, for a tour of the antiquities of Jordan. Dr. Ghazi Bisheh, the Director of Antiquities, arranged for interviews and transportation to see the major archaeological sites. This naturally featured a visit to Aqaba and the Oriental Institute excavations there. The Aqaba Inspector, Sausan Fakhry, showed us the immense changes wrought by a new hotel built directly beside the site. She has been laboring to lessen its impact and to secure and beautify the site, a Herculean task. Finally she showed us the excavations of “the earliest church,” uncovered by the University of North Carolina in Aqaba and subject of some uncertainty. A few days later Suleiman Farajat arranged a tour of Petra and we saw the beautiful, newly protected Petra church. Bill’s only comment was “Now, *that’s* a church.”

Returning to Chicago, Don participated in a special session of the Middle East Studies Association organized for the Syrian Studies Association by Dorothee Sack from Berlin. He presented “Two Abbasid Farmsteads near Tell Sweyhat.” The irony is that these materials, collected over 25 years ago, now fit a pattern clarified by the results from Hadir Qinnasrin and other recent work in Syria. In the midst of this Syrian involvement, Don was filmed for an Iranian television documentary on the archaeology of Iran. Over the past few years, Don has maintained his original interest in Iran by writing a series of articles for *festschriften*. In addition to waiting for publication of these articles, two long-awaited articles on Arabia suddenly descended, “Out of Arabia: Early Islamic Aqaba in its Regional Context” and “The Darb Zubayda as a Settlement System in Arabia.”

Finally, this year marks the fruition of many years of promoting Islamic archaeology – the arrival of a group of students specializing in this field. Since the number of archaeology students and students from other areas of the Department of Near Eastern Languages and Civilizations has grown, Don offered an increasing number of courses, including Egypt after the Pharaohs, Late Levant, and major revisions in his Introduction to Islamic Archaeology.

Tony J. Wilkinson

Fieldwork in 1998 consisted of rather brief campaigns in Syria (Tell Beydar) in the second half of August and in Turkey (the Amuq) in September (see separate reports). **Tony J. Wilkinson** spent the remainder of the academic year in Chicago dealing with teaching, writing, and other academic activities.

The academic year started with a new initiative: The Interdisciplinary Archaeology Workshop, which is intended to provide a forum for archaeologists on cam-

RESEARCH

pus to get together to listen to seminars presented by a wide range of speakers that include both senior faculty visitors as well as graduate students, with an emphasis on the latter. The workshop builds on the foundation laid by the Archaeology Committee of the University of Chicago, especially the long-running workshop, run by McGuire Gibson, "Elementary Structures of Everyday Life." The new workshop managed to draw some good crowds, including some who came from the Oriental Institute as well as the departments of Anthropology, South Asian Studies, Classics, and even beyond the University of Chicago. The primary venue, the downstairs lounge in Pick Hall, was chosen as good symbolic space because it did not represent the "turf" of any member department. The 1998/99 theme "Landscape and Society," was suitably vague to attract a broad and varied audience, as well as a wide range of interpretations of that much abused term "landscape." Probably our most exciting workshop of the series was a special Saturday morning session on 26 March presented by Robert McCormick Adams, former director of the Oriental Institute, and co-worker Jennifer Pournelle, both now affiliated with the University of California at San Diego. The basic thrust of their presentation focused upon the latest results of their program of remapping the Mesopotamian plains using the declassified satellite images (the CORONA series). Not only were they able to provide much additional information on the relict course of the Tigris-Euphrates river systems, but also the fine resolution of the images (taken on United States spying missions in the 1960s and 1970s) enabled them to map what appear to be Parthian, Sasanian, or early Islamic field and irrigation systems. We hope to follow this stimulating and important session with a larger, more formalized meeting in December 1999.

The University of Chicago/Argonne National Laboratory Collaborative Grant (with McGuire Gibson of the Oriental Institute and John Christiansen of Argonne National Laboratory) was renewed for a second year. Steve Cole, visiting scholar for part of 1998/99, was added to the roster and provided exceptionally valuable advice on textual sources for ancient agriculture and population. At the time of writing (July 1999) the first primitive model showing the effects of fallowing on ancient crop yields has emerged, but because some of the parameters employed were estimates from United States analogs, this initial model is more applicable to Iowa than to Subartu. Nevertheless, the initial model demonstrates that progress is being made. At the same time as advances were being made with the collaborative grant, new laboratory space was occupied in the basement of the Oriental Institute. Wilkinson's laboratory is dedicated primarily to remote sensing and Geographical Information Systems and provides space for graduate students Jason Ur and Carrie Hritz to use the United States military declassified (CORONA) images to produce maps of the ancient Bronze Age landscape of northern Syria.

Various lectures were given during the year. On 11 March 1999 a talk on "Differential Sedimentation and Archaeology in the Amuq, Turkey" was presented as part of a Workshop on Geoarchaeology and Archeometry at the University of Laval, Quebec, Canada. Another lecture was given on 21 May 1999, at a splendid workshop at Leiden University, Netherlands, organized by Remko Jas, formerly of the Chicago Assyrian Dictionary Project, on "Settlement and Land Use in the Zone of Uncertainty in Upper Mesopotamia"; the meeting brought together specialists in Akkadian, Assyriology, archaeobotany, faunal analysis, geoarchaeology, and ar-

chaeology in an attempt to forge a better and more integrated understanding of ancient land use systems in Upper Mesopotamia. Several papers were also presented on the Balikh, that majestic alluvial corridor in northern Syria. Among them was an excellent paper by graduate student Jerry Lyon on settlement associated with the Middle Assyrian frontier around Sabi Abyad.

A number of talks were also given, including: "Bronze Age Settlement, Environment and Terraced Agriculture in Highland Yemen" at the Marching and Chowder Society Annual Meeting, Wellesley College, near Boston, on 24 October 1998; "Settlement Patterns in Northern Syria from the Bronze Age to the Roman/Parthian Period" as part of the Archaeological Institute of America lecture series at the Program of Classical Art and Archaeology, University of Michigan, Ann Arbor, on 1 December 1998; and also "Problems in Regional Archaeology and Archaeological Survey," at the Department of Classics, University of Cincinnati, Ohio, 1 March 1999, and again on 1 April 1999, at the Department of Anthropology, University of California at San Diego, California.

Talks in and around Chicago included: "Geoarchaeology" at the Department of Geophysical Sciences, University of Chicago, Student Workshop, on 11 November 1998 and again on 9 April for the faculty and others on "Environmental Change and Human Settlement in the Ancient Near East"; also on 18 March 1999, "In Highest Yemen: Origins of Terraced Fields in Ancient Arabia" to the South Suburban Archaeological Society, Homewood, Illinois; and finally, on 26 March 1999, "Archaeological Modeling and Environmental Fluctuations" at the Society for American Archaeology, Annual Meeting, Chicago, Illinois.

In terms of publications, the monograph entitled *Settlement and Land Use at Tell es-Sweyhat and in the Upper Lake Tabqa, Syria* is gradually attaining its final form prior to being submitted for publication. Articles published during the year included "Settlement and Irrigation in the Balikh Valley, Syria from the Third to the First Millennium BC," in *Subartu* 4/1: 151–70; "Demographic Trends from Archaeological Survey: Case Studies from the Levant and Near East," in *Long-term Demographic Trends in the Mediterranean Basin*, edited by John Bintliff and Kostas Sbonias (Oxford: Oxbow Books); "Holocene Valley Fills of Southern Turkey and Northwest Syria: Recent Geoarchaeological Contributions," in *Quaternary Science Reviews* 18: 555–71; and "Surveys and Excavations in Highland Yemen," with Chris Edens, in *Arabian Archaeology and Epigraphy* 10: 1–33.

K. Aslihan Yener

During 1998, **K. Aslihan Yener** directed the fourth season of work at the Amuq Valley Regional Project in the Hatay, Turkey. Tell Kurdu was targeted as the first site for intensive excavation (see separate report on the Amuq Valley Regional Project). The location of the dighouse headquarters on the experimental farm of the Mustafa Kemal University (Selam Tesisler) was mapped out and plans for the first building were finalized. The upcoming excavation house and research program became the focus of a funding campaign both in Chicago and Antakya. To that end a

RESEARCH

committee of friends was organized to operate the campaign. Sel Yackley was elected as Chair, Matt Argon as Secretary. Other members include A. Lash, E. Singer, Y. Selçukoğlu, T. Kuzay, E. Alp, and M. Akgön.

The work in the Amuq is published in "Oriental Institute Returns to the Amuq. 1998 Excavation Season at Tell Kurdu, Turkey," in *News & Notes* 161 (Winter 1999): 1–3; "Amuq Valley Regional Project," with T. J. Wilkinson, in *The 1997/98 Annual Report*, pp. 9–15; "1996–1997 Yılları Oriental Institute Amik Ovası Projeleri: Yızey Araştırmaları, Arkeometri ve Tell Kurdu Kazısı" [The 1996–1997 Oriental Institute Amuq Valley Regional Project: Survey, Archaeometry, and Excavations at Tell Kurdu], with T. J. Wilkinson, in *XIV. Arkeometri Sonuçları Toplantısı*, pp. 97–112 (1999); and "Analytical Investigation of Archaeological Powders from Göltepe, (Turkey)," with A. Adriaens, P. Veny, F. Adams, R. Sporken, P. Louette, B. Earl, H. Özbal, in *Archaeometry* 41 (1999): 81–90. In addition a new website was prepared for the Amuq Valley Regional Project: <http://www-oi.uchicago.edu/OI/PROJ/AMU/Amuq.html>. This URL is case-sensitive.

In addition to teaching and committee work, Yener delivered papers entitled "Integrated Center Approaches to the Anthropology of Archaeometry," at the Archaeometry as Anthropology, Material Culture and Technology Center for Archaeological Investigations, Southern Illinois University, Carbondale, 20–21 March 1999; "Between the Tigris-Euphrates Basin and the Mediterranean Sea: Tell Kurdu Excavations, 1998," at the Oriental Institute; and "Fantastic Imagery in Prehistoric Anatolia," at Hokin Memorial Lecture, School of the Art Institute of Chicago, 19 April 1999. Yener acted as the co-chair of a session entitled Integrated Approaches to the Study of Ancient Technology and Environment: Archaeological Science and the Potential for a Center Mode of Operation Society for American Archaeology meetings, Chicago, Illinois, 27 March 1999; "The Oriental Institute Amuq Valley Regional Project: The 1998 Tell Kurdu Excavations," Meetings of the International Symposium of Excavations, Surveys, and Archaeometry, 25–29 May, Ankara, Turkey; and "The Oriental Institute Amuq Valley Regional Project: The 1998 Tell Kurdu Excavations," Antiocheia Ad Orontes, a symposium on Excavations in the Hatay Province, Mustafa Kemal University, Antakya, Turkey.

COMPUTER LABORATORY

John C. Sanders and Peggy M. Sanders

I had hoped to be writing this annual report from the new Computer Laboratory in the Institute, Room 202, but two more preliminary phases to the actual move still await completion. A brief synopsis follows:

The overall scheme involves several people playing musical offices: moving the Computer Laboratory into Room 202; moving my office into Room



Guardian man-bulls of east doorway. Gate of Xerxes, Persepolis

205, which Oriental Institute Professor Norman Golb will vacate; and moving Professor Golb's office into Room 232, the Computer Laboratory's present location. Additionally, the former second floor fainting room, where the Institute's network equipment and Museum Education storage are currently located, will become the new computer server and network equipment room.

Here is how this process has unfolded. In September 1998 the process started by moving the Museum Education Office from Room 202 to Room 221. In early summer 1999 we moved part of the Museum Education's materials from the former second floor fainting room to the third floor fainting room. In July 1999 the required electrical work was completed in Room 202 and the former second floor fainting room. All that remains is adding additional computer network wiring to all three rooms and the electrical work required in Room 205, after Professor Golb has been moved. Both of these jobs should be completed by early October 1999. I will summarize the entire process, and breathe a sigh of relief that it is all over, in next year's *Annual Report*.

Center for the Study of Ancient Technologies and Environments (CSATE)

Throughout spring and summer 1998 I worked with Oriental Institute Professor Ashhan Yener and several University and Argonne National Laboratory's scientists to outline the computer hardware specifications, networking and data backup strategy, and data management system requirements that were included in the Institute's 1998 CSATE grant proposal to the National Science Foundation (NSF).

RESEARCH**New Oriental Institute Email System**

With the assistance of Mr. Christopher Barnard, the former computer systems administrator for the University's Computer Science Department who now works for the Chicago Board of Trade, the Institute switched its email system from Macintosh-based QuickMail to the built-in capabilities of a unix-based server. The Institute now has a more flexible email system with much larger storage capacity. The downside to switching was the four months (September 1998–January 1999) it took to instruct the Institute's faculty and staff, one at a time, on how to move email messages from the old to the new system, and teaching almost everyone in the Institute how to use the Eudora email program to access their new email account on our unix server.

The biggest headache involved email address books. Because of the way the old QuickMail program was written everyone's QuickMail address books could not be automatically converted into the format used by the Eudora program. I had the unpleasant task of informing each faculty and staff member that they would have to either retype or "cut-and-paste" all the names and addresses from the old to the new system. For some this was not very time consuming, for others it was a major task. At least the Eudora program's format for address books means that if we need to switch email systems in the future we will be able to automate that conversion process!

Year 2000 Problem (Y2K)

I started to perform the Y2K operating system updates on the Institute's four unix computers in March 1999. One is done, three to go before 31 December. We are making every effort to bring all our systems into compliance. We anticipate no problems with unix machines, few or no problems with Macintosh products, and will upgrade Windows 3.x and 95 computers to Windows 98 as quickly as possible. The Institute's two Windows NT computers will have service pack 5 installed to bring them into compliance.

Chicago Hittite Dictionary Project

The Oriental Institute's website took on a new role this year when Professor Harry Hoffner said he would like to use the Hittite Dictionary's homepage to distribute versions of forthcoming dictionary articles to a small, select group of Hittite scholars around the world for review prior to publication. Being the first such request I have had for the website, Charles Jones, Professor Hoffner, and I had several discussions about what file format to store the documents in and how best to serve up the documents to this limited audience. Because of the variety of computer platforms (Windows, Macintosh, and unix-based) these scholars might be using, the even-larger variety of word processing programs they might employ to view these documents, and the almost insurmountable problem of platform-specific fonts, it did not take us long to decide on the Adobe Acrobat Portable Data Format (PDF) as the preferred method.

Because Professor Hoffner only wanted a select group of scholars to have access to these dictionary documents, I created a password-protected directory within the Hittite Dictionary's section of the website, and each scholar was given this pass-



Throne hall, portico, and north part, with Darius' Palace and Apadana in background. Persepolis

word. All they had to do was download from the Adobe website the free “plug-in” for their web browser software of choice and install it on their computer system.

At this point the process goes as follows: as each new dictionary document is created by Professor Hoffner, I create a link to it in the Hittite Dictionary’s website, and he emails the group of scholars to inform them that a new document is ready for their review. They use their web browser to connect to the Hittite Dictionary website, click on the appropriate link, and the new dictionary article appears on their web browser exactly as it was created by Professor Hoffner, including all fonts, type sizes, and diacritical marks, regardless of which computer system or web browser software each reviewer might choose to use.

Persepolis and Ancient Iran

For several years the Photographic Archives section of the Institute’s website has contained a catalog of the 999 photographs from a 1976 Oriental Institute text/microfiche publication entitled *Persepolis and Ancient Iran*. A comprehensive survey of archaeological sites in the environs of Persepolis, Iran, the catalog is divided into four sections, summarizing the major areas of investigation: the architecture, reliefs, and finds of the Palaces at Persepolis; the prehistoric mound of Tall-i-Bakun; Istakhr, the Islamic city mound; and the aerial survey flights conducted between 1935 and 1937. It did not, however, contain any of the actual photographs from the microfiche publication but was just a listing of each photograph’s caption.

During summer, fall, and winter 1998, Professor Matthew Stolper and one of his students, Michael Kozuh, scanned into computer files the 957 black and white photographs from this publication which were already printed and stored in the

RESEARCH

Institute's Photographic Archives. I then put out a call for volunteers to help process these computer images into a format suitable for inclusion in the Persepolis and Ancient Iran section of the website. When I advertised for volunteers I estimated it would take four to six months to complete the project, assuming we had several people working part time. Five Oriental Institute docents (Peggy Grant, Irene Glasner, Lyla Bradley, Nancy Gould, and Nancy Terras) volunteered immediately, and all were quick learners. They kept the pressure on me to provide them with the raw data they needed to do their job. Almost daily throughout February and March 1999, either Peggy, Irene, Lyla, Nancy, or Karen were in the Computer Laboratory using the Photoshop program to prepare the scanned images or using a text editor program to create the HyperText Markup Language (HTML) caption pages for each photograph. From a start date of 5 February the final photographs were put on the website on 30 March, a far cry from the four to six months I had originally thought!

Response to the availability of this large photographic collection via the internet by both scholars and the general public has been very positive. I applaud the perseverance of both Professor Stolper and Michael Kozuh, as well as our docents, and cannot thank them enough for the marvelous addition to ancient Iranian studies and the Institute's website that their efforts produced.

1905–1907 Breasted Expedition to Egypt and Sudan

Reminiscent of the Persepolis and Ancient Iran project above, a second publication of the Oriental Institute is in the process of being converted to a web-based format. With the gracious help of Docent Irv Diamond, the 1975 Oriental Institute text/microfiche publication entitled *The 1905–1907 Breasted Expedition to Egypt and Sudan: A Photographic Study* was scanned using optical character recognition software during spring 1999. A catalog of the captions for about 1,100 photographs taken by James Henry Breasted, the Oriental Institute's founder, during his early travels throughout Egypt and Sudan has now been compiled. Oriental Institute Research Associate Bruce Williams volunteered to track down the exact location of some of the Nubian sites Breasted photographed (the original print publication did not contain a map of the region locating the 70+ sites). This work still needs to be completed, but I expect this new addition to the Institute's website will be available in fall 1999. I anticipate seeking volunteers in early 2000 to once again scan the enlarged prints we have of these photographs in the Institute's Photographic Archives, and then to edit, crop, and process these computer files so they can also be made available to scholars and the public via our website.

Epigraphic Survey Photographic Negative Database Program

Graduate student Jason Ur, who wrote the FoxPro source code for the Epigraphic Survey's new photographic negatives database management program, spent part of summer 1998 fixing minor problems with the program after its second season of use at Chicago House. By all accounts the staff is pleased with the program's speed and its ease of use when they need to retrieve information on a particular photograph in the database. The error-checking routines that Jason built into the "add a new record" portion of the program save time, reduce keystrokes, and eliminate many common data entry errors.

When the program was first written during summer 1997, I converted all of the data from the Epigraphic Survey's existing computer database into the new database structure through the use of several conversion programs that I wrote. Unfortunately, many hours of manual labor still lie ahead for the Epigraphic Survey staff in order to take full advantage of the new program's relational database capabilities because of the different file structures in the old and new programs. Some of this work can be automated through the writing of additional conversion programs, but some will require hours of retyping data. I hope to report on how this process is proceeding in next year's *Annual Report*.



Detail of Bactrian tribute bearer. East stairway, Apadana, Persepolis

Adult Education Courses on the Internet

Working in conjunction with the Museum Education Office, I assisted Research Associate Steve Vinson and graduate student Nicole Hansen in developing two on-line adult education courses. Both were accessed via the Institute's website and our majordomo list server. Steve's on-line course, *Ancient Mariners*, operated during late spring and summer 1999. Nicole's on-line course, *Egyptian Folklore*, operated during summer and early fall 1999. In both cases all of their respective website pages were designed and created by themselves. I just offered constructive criticism and suggestions on issues such as file structure and image sizing and formats, and performed routine maintenance and file uploading procedures for both courses.

Laboratory Equipment / Institute Resources

As predicted in last year's *Annual Report* the Computer Laboratory's 35 mm slide scanner was smoking throughout most of this year as several student workers, including Tasha Vorderstrasse, Aaron Burke, and Joey Corbett worked to scan the entire Ashkelon slide collection into digital format for inclusion in the Ashkelon database being developed by Professor David Schloen.

In December 1998 the Computer Laboratory acquired its first true Geographic Information Systems (GIS) software, a suite of programs called ArcView (the basic program, as well as the Spatial Analyst, the 3D Analyst, and the Image Analyst extensions). The software operates on the Laboratory's Windows NT computer and will provide tremendous capabilities for archaeological survey and site analysis.

RESEARCH

In January 1999, the Computer Laboratory's CD-ROM "burner" was brought on-line, so Institute faculty and staff can write data in CD-ROM format for long-term storage and archival purposes.

I want to thank Mr. Edward Anders, a member of the Institute, for his donation of a Macintosh Classic II computer system and modem to the Computer Laboratory. The computer found a new home in the Institute on the Security desk in the lobby.

I extend the same thanks to Mr. Christopher Barnard and his wife, graduate student Shelley Luppert-Barnard, for their donation of a Macintosh IICI computer and monitor, which spent the past year serving as a terminal for accessing the Research Archives On-Line Catalog from the new Stacks Room.

Lastly, I am most appreciative of the contributions given by Mrs. S. Chandrasekhar and Maggie Brandt to the Computer Laboratory's operations.

World-Wide Website

For further information concerning several of the above mentioned research projects, the Institute's World-Wide Web database and other electronic resources in general, please refer to (case sensitive):

http://www-oi.uchicago.edu/OI/INFO/OI_WWW_New.html

The homepage for the Oriental Institute website is at:

<http://www-oi.uchicago.edu>

PUBLICATIONS**Thomas A. Holland**

The staff of the Publications Office remained unchanged: Thomas Holland and Thomas Urban in the Editorial Office and Christopher Kahrl in the Sales Office. Most of the year was spent preparing the two Persepolis volumes, text and plates (OIP 117) and the Wente festschrift (SAOC 58), both of which are quite large. Some time was found to help Professor Martha Roth and Manuscript Editor Linda McLarnan guide Chicago Assyrian Dictionary Volume R to the printer and Volumes T and P to the typesetter.

Volunteer Irv Diamond scanned Professor Janet Johnson's *Demotic Verbal System* (SAOC 38) with optical character recognition software and oversaw proofreaders Ruth Caraher, Irene Glasner, Denise Paul, Kathy Mineck, and Thomas Dousa who prepared it for reprinting. Irv had previously done the same type of work for William Murnane's *Ancient Egyptian Coregencies* (SAOC 40), which we hope to reprint in the future.

Three volumes went out of print this year — *Tomb of Kheruef* (OIP 102), *Thus Wrote 'Onchsheshonqy* (SAOC 45; second revised edition), and *Life in a Multi-*

Cultural Society (SAOC 51) — one of which, SAOC 45, we plan to reprint next year.

The Sales Office held its second book sale for members, its annual fall book sale for students, and sold books at the American Research Center in Egypt's Chicago conference, doing quite well at each.

Table of Sales

<i>Series</i>	<i>Number of Volumes Sold</i>
Assyriological Studies (AS)	121
Chicago Assyrian Dictionary (CAD)	440
Chicago Hittite Dictionary (CHD)	92
Materials and Studies for Kassite History (MSKH)	8
Oriental Institute Communications (OIC)	24
Oriental Institute Museum Publications (OIMP)	8
Oriental Institute Nubian Expedition (OINE)	30
Oriental Institute Publications (OIP)	471
Oriental Institute Special Publications (OISP)	17
Studies in Ancient Oriental Civilization (SAOC)	432
Miscellaneous*	96
TOTAL	1,739

*Volumes published jointly with other institutions:

Dating the Fall of Babylon: A Reappraisal of Second-Millennium Chronology. H. Gasche et al.

Uch Tepe 1: Tell Razuk, Tell Ahmed al-Mughir, Tell Ajamat. McG. Gibson, ed.

Uch Tepe 2: Technical Reports. McG. Gibson, ed.

Volumes Printed

1. *Reliefs and Inscriptions at Luxor Temple, Volume 2: The Facade, Portals, Upper Register Scenes, Columns, Marginalia, and Statuary of the Colonnade Hall.* The Epigraphic Survey. OIP 116
2. *Changing Watercourses in Babylonia: Towards a Reconstruction of the Ancient Environment in Lower Mesopotamia, Volume. 1.* H. Gasche and M. Tanret, eds. Joint Publication of the University of Ghent and the Oriental Institute of the University of Chicago. Mesopotamian History and Environment, Series 2, Memoirs 5

Volumes in Preparation

1. *The Assyrian Dictionary of the Oriental Institute of the University of Chicago, Volume 15, S. Reprint*
2. *Seal Impressions on the Persepolis Fortification Tablets, Part 1: Images of Heroic Encounter.* M. B. Garrison and M. C. Root. OIP 117
3. *Gold of Praise: Studies in Ancient Egypt in Honor of Edward F. Wente.* E. Teeter and J. Larson, eds. SAOC 58

RESEARCH

Manuscripts Accepted for Publication

1. *Bir Umm Fawakhir: A Byzantine Gold-Mining Town, Survey Project 1993*. C. Meyer, L. Heidorn, W. Kaegi, and T. Wilfong.
 2. *Theban Desert Road Survey, Volume 1: Rock Inscriptions of Gebel Tjauti, Part 1*. J. C. Darnell and D. Darnell.
 3. *Scarabs, Scaraboids, Seals, and Seal Impressions from Medinet Habu*. E. Teeter.
 4. *Demotic Egyptian Texts in the Brooklyn Museum of Art*. Joint Publication of the Oriental Institute of the University of Chicago and the Brooklyn Museum of Art. G. R. Hughes.
 5. *Studies in the Archaeology of Israel and Neighboring Lands in Memory of Douglas L. Esse*. Joint Publication of the Oriental Institute of the University of Chicago and Scholars Press. S. Wolff, ed.
 6. *Excavations at the Prehistoric Mound of Chogha Bonut, Khuzestan, Iran: Seasons of 1976–1978 and 1996*. A. Alizadeh.
 7. *Cuneiform Texts from the Ur III Period in the Oriental Institute, Volume 2: Drehem Administrative Documents from the Reign of Amar-Suena*. M. Hilgert.
 8. *The Neo-Babylonian Texts of the Oriental Institute Collection*. D. Weisberg.
-

RESEARCH ARCHIVES**Charles E. Jones**

Sitting in the cool silence of the Elizabeth Morse Genius Reading Room of the Research Archives during the July heat wave, I can see a crowd of faculty, staff, and students. Joining them this month are visiting scholars from Austria, Egypt, Israel, and Italy, as well as colleagues from California, Colorado, Maryland, and Tennessee. All of them are here to work with the resources of the Research Archives: many of them come each summer. This is the second year they can work here in comfort.

We have made great progress this year with two important and related projects. Firstly, the reconfiguration of the collections is essentially complete. The map room on the upper level is in place and functional (with great strides having also been made towards the cataloging of the map collection [see the statistics below]). The pamphlet collection has been moved to the upper level and the quickly growing bibliography section (at the base of the stairway) is now established, while the monographs (in the new wing) and series (in the reading room) are now thoroughly sorted. Secondly, the winter months saw the successful completion of the raising of the matching funds for the renovation of the Morse Genius Reading Room. As a

consequence of the diligent work of the Development Office staff and the generosity of donors we have exceeded the goal of \$84,800.00, successfully meeting the challenge presented to us by the Elizabeth Morse and Elizabeth Morse Genius Charitable Trusts. Those trusts have matched our funds with \$70,000 as promised. More than ninety donors contributed to the achievement of this goal, including many members of the scholarly community (many of whom are alumni). The response has been extraordinarily gratifying to me, and testifies to the esteem in which the Research Archives is held among those groups.

At the time of writing we are now nearly ready to begin work on the project, and fully expect to have the construction complete by the end of September in time for the beginning of the Autumn Quarter. The plans for the project include replacement of the original lighting in the reading room, establishment of power and internet connections at each of the tables in the reading room, and replacement of the cork flooring. Once these improvements are complete, the library will again be "the most beautiful room in the building."

On-line Catalog and Retrospective Cataloging Project

The on-line catalog of the holdings of the Research Archives now includes 84,640 records. It is up-to-date for all materials acquired through the end of May 1999. More than twenty-seven hundred records have been added to the database during the past year. With the help of our software supplier, we have now converted the database to the most recent version of the software and have the hardware and software poised to make the catalog fully accessible over the internet. As the summer progresses, we will, with the help of John Sanders and the Computer Laboratory, have this new version up and running on an independent Research Archives web server. With this development, the catalog will be accessible world-wide, and its role as a research tool will consequently change in interesting ways. It will be a stimulating challenge to observe and adapt to these changes, and I look forward to communicating with the larger academic community that will have access to the catalog for the first time.

Complete, and in the final stages of editing preparatory to loading into the on-line catalog, are analytical records for each essay, article, and review in the following periodicals:

<i>Item</i>	<i>Number of Records</i>
<i>Annales du Service des antiquités de l'Égypte</i>	1,830
<i>Oriens Antiquus</i>	1,083
<i>Semítica</i> (volumes)	409
<i>Tel Aviv</i>	247
<i>Zeitschrift der Deutschen morgenländischen Gesellschaft</i>	1,404
<i>Zeitschrift des Deutschen Palästina Vereins</i>	2,181
<i>Zeitschrift für die alttestamentliche Wissenschaft</i>	1,106
Map collection	3,455
Total of records in retrospective cataloging project	11,715

RESEARCH

In addition, we have processed 8,659 analytical records from material acquired during the past year, giving us a grand total of 20,374 analytical records prepared during 1998/99 for entry into the on-line catalog.

Publications

The Research Archives published or revised eight electronic items during the past year:

1. **Abzu: Guide to Resources for the Study of the Ancient Near East Available on the Internet**, by Charles E. Jones. Chicago: Oriental Institute Research Archives, 1994–1998. Oriental Institute Research Archives Bibliographical and Informational Documents: Supplements to Oriental Institute Research Archives Acquisitions List, volume 3. Available exclusively on-line.

<http://www-oi.uchicago.edu/OI/DEPT/RA/ABZU/ABZU.HTML>

With more than 750 new entries in the past year, Abzu remains the most complete index to on-line materials relating to the ancient Near East.

2. Search the Oriental Institute Web space.
3. **Persepolis and Ancient Iran: Thumbnail Images from Oriental Institute Web Pages.** (This page includes more than a thousand images and will take some time to load. Please be patient.)

<http://www-oi.uchicago.edu/OI/DEPT/RA/Iranthumbs.html>

4. **Ancient Egypt and Nubia: Thumbnail Images from Oriental Institute Web Pages.** (This page includes nearly two hundred images and will take some time to load. Please be patient.)

<http://www-oi.uchicago.edu/OI/DEPT/RA/Egyptthumbs.html>

5. **Dissertation Proposals in Ancient Near Eastern Studies Approved by the Department of Near Eastern Languages and Civilizations, the University of Chicago:**

Continuity and Change of Reproductive Beliefs and Practices in Egypt from Ancient to Modern Times. Nicole B. Hansen

http://www-oi.uchicago.edu/OI/DEPT/RA/DISPROP/hansen_diss.html

6. **International Association of Orientalist Librarians (IAOL): WWW Presence.**

<http://www-oi.uchicago.edu/OI/IAOL/iaol.html>

7. **Rencontre Assyriologique Internationale/International Congress of Assyriology and Near Eastern Archaeology: XLV^e Rencontre Assyriologique Internationale, 5–8 July 1998, Cambridge, Massachusetts, and 9–10 July 1998, New Haven, Connecticut**

http://www-oi.uchicago.edu/OI/DEPT/RA/rai/45_2ndCirc.html

8. In addition, nearly all of the other on-line publications of the Research Archives have been revised, updated, and expanded.

http://www-oi.uchicago.edu/OI/DEPT/RA/Research_Arch.html

All URLs are case-sensitive.

Other Activities

A number of continuing projects and initiatives have been based out of the Research Archives during the past year:

Oriental Institute Staff Newsletter. Intended to increase the level of communication among the units, projects, faculty, and staff of the Oriental Institute in Chicago and abroad, this e-mail based newsletter is issued monthly during the academic year.

“Techno-lunches.” Informal presentations and discussion of projects in ancient studies that have technological components in their production or presentation. Meeting monthly, interested faculty, staff, and students use this forum to develop a perspective on the wide variety of projects underway at the Oriental Institute.

Oriental Institute Arabic Manuscript Project. In collaboration with, and funded by, the Regional Information Technology and Software Engineering Center (RITSEC) in Cairo, and with the essential cooperation of the Oriental Institute Museum, this project is preparing detailed photographs of, and catalog records for, many of the Arabic Manuscripts — primarily papyri — in the collections of the Oriental Institute Museum. Most of them will become available for the first time as a consequence of this project.

Oriental Institute Website Development. In collaboration with the Computer Laboratory we continue to develop the website which is as wildly successful as ever — now having more than three quarters of a million hits each month.

Cooperative On-line Resource Catalog (CORC). The Research Archives is collaborating with the Technical Services department in Regenstein Library in a pilot project — the Cooperative On-line Resource Catalog (CORC) — to provide useful and properly formatted records for a corpus of on-line resources. CORC is working with Abzu and its links to materials published on-line at the Oriental Institute website as a launching pad and test case. You can already find Abzu itself, Richard Jasnow’s article “Graffiti of Luxor Temple” (from the *Chicago House Bulletin*), and many other such on-line resources culled from the links in Abzu in the University of Chicago’s on-line catalog Horizon. If you care to investigate, CORC is described at: <http://www.lib.uchicago.edu/Annex/TechSvcs/corc.html>.

Current Acquisitions

Following are the acquisitions statistics for the past year:

	<u>May 1998–April 1999</u>	<u>Total</u>
Monographs and Series	613	23,364
Journals	216	9,682
Total Books	829	33,046
Pamphlets	4	

The statistics are slightly down from last year due to a number of factors. Significant among these is the delay in shipping resulting from the requirement to prepay for many of our orders. This requirement is increasingly common among publishers and is particularly acute among the publishers with whom we had to cancel significant standing orders following the budget crisis of the mid-1990s.

RESEARCH

While we do not have a means to keep visitor statistics, it is clear that the Research Archives is more heavily used than ever before. Three factors are important in the increased use:

1. Climate control makes the room a much more comfortable place to work.
2. The increased number of tables and work spaces facilitates the use of the collection and reduces crowding.
3. The increasing participation of faculty in teaching survey classes and classes of wider interest to students outside the department has raised the profile of this resource among other units of the University.

The Research Archives remains one of the central North American research facilities in ancient Near Eastern studies. Many scholars from outside the University of Chicago make periodic trips to this facility to conduct research. For example, more than a dozen Egyptologists took the opportunity of the Chicago location for the ARCE meeting this Spring to spend additional days on research here in the Research Archives.

Staff

Two members of the staff, Hratch Papazian and Justine Way, left at the end of summer 1998, the former to work at Chicago House in Luxor, and the latter to concentrate on studies and to continue work at Giza. Later in autumn, Alexandra O'Brien also left to complete her dissertation on women in Hellenistic Egypt. I am grateful to all three of them for their careful and diligent work and their pleasant and agreeable presence on the staff for so long. For most of the year, the staff of the Research Archives was entirely new. Aaron Burke, third-year graduate student in Archaeology, shouldered the task of cataloging the map collection. Katherine Strange, first-year graduate student in Archaeology, and Tamara Siuda, first-year graduate student in Egyptology, shared the analytical cataloging tasks for both the current acquisitions and the retrospective cataloging project. All three shared office duties and covered weekend and evening hours. A qualified and interested staff is a key component of any organization, and I am pleased to have had this group working with me this year.

Thanks

In a year in which so many individuals and organizations contributed so much to the future of the Research Archives, it is difficult to single out specific contributions. As always, my colleagues at the Oriental Institute are essential to the smooth and successful operation of the Research Archives. The Director, Professor Gene Gragg, and his staff have constantly and consistently supported the Research Archives. Professor Robert Biggs and the *Journal of Near Eastern Studies*, and Denise Browning and her staff in the Suq are, as always, generous with books, information, and moral support. But it is John Sanders and the Computer Laboratory whose generosity with time, experience, effort, and advice to whom I am most indebted for the continuing development of the Research Archives. To each of them, and to all who offered help and support, my thanks.



MUSEUM

Overleaf. Head of Conservation Laura D'Alessandro carefully prepares legs of King Tutankhamun statue after his move to the Grimshaw Gallery. Photograph by Jean Grant

MUSEUM

Karen L. Wilson

This past year saw the completion of the final phase of the renovation, expansion, and climate control project in September and the reopening of the museum to the public at the end of May. It was a hectic, exhausting, and exhilarating twelve months! But it is so wonderful to once again have access to our collections and to be a functioning museum with a public face that it makes it all very much worthwhile in the end.

The new Joseph and Mary Grimshaw Egyptian Gallery has been a tremendous public success, with 11,065 visitors between the first opening event on 22 May and the end of the fiscal year! I wish to express my gratitude to each and every member of the museum staff who made it all possible. Emily Teeter worked indefatigably while I was immersed in the building project to give the exhibition thematic form and to try to choose objects for exhibition when they all were packed away in boxes. John Larson, Carole Krucoff, and Joe Scott worked with Emily and me to finalize selections and display arrangements and to massage into final form the hundreds of labels Emily was cranking out on her computer. The conservators — Laura D’Alessandro, Susan Holbrook, and Sara Caspi — moved hundreds of objects through the laboratory to get them ready for display and, along with many other people, pitched in at the last minute to perform such unglamorous tasks as polishing glass. Preparators Joe Scott, Steve Wessley, and Randolph Olive covered what seemed like miles of plywood with fabric for case buildups, built new walnut case-work, made hundreds of object mounts, produced labels and text panels, and provided valuable input on the design and arrangement of the “finished” gallery. Ray Tindel unpacked objects, kept track of them, and lent his considerable handyman skills to the installation — and was also the only one of us who was here at 7:30 in the morning to let workmen into the gallery. Jean Grant managed to get her photographic studio ready to shoot pictures of the objects of which we had no images, and Margaret Schröder proofread all the labels and text panels, tidied up the other galleries so we would be somewhat presentable to our public, and strung miles of caution tape to keep that public under control. Anne Yanaway made purchases, fielded telephone calls, and — along with John Larson — produced all the final labels and text panels in the course of one Saturday on which we all would have rather been doing other things. Carole Krucoff, Terry Friedman, Cathy Dueñas, and everyone else in Museum Education put in long hours to have docents and programming ready for our many opening events, and succeeded admirably.

In addition to the museum staff, Associate Professor Robert Ritner chose objects and wrote labels and didactic materials for the case on Egyptian Magic and Medicine, and he and the other Egyptologists will be working with us over the next several months to give the gallery its final form. We owe a special debt of gratitude to John Vinci and Tom Conroy of Vinci/Hamp Architects, Inc. for their elegant design and to the staff of Kiple Construction for making that design a reality. It will be exciting over the next year to watch how people use and react to the gallery and to begin work on the other installations.

MUSEUM

Of course, the reinstallation meant that Ray and his “staff” had to retrieve (and, in many cases, first unpack) and keep track of all the objects that Emily was considering for use, which proved ultimately to be nearly a thousand pieces. And it is ironic that never before this year had faculty, students, and visiting scholars made such heavy use of the collections. Apparently, four years of inaccessibility produced a pent-up demand that erupted as soon as we could provide them with materials. For example, records in Registration show that Assistant Professor David Schloen used nearly 300 sherds and whole vessels to teach his Syro-Palestinian pottery course and members of Professor McGuire Gibson’s Diyala Objects Project requested over 500 objects to study. In addition, graduate students Tasha Vorderstrasse and Colleen Coyle both made extensive use of the collections for their Masters theses. Tasha conducted a careful survey of the 600 coins from the Amuq excavations and Colleen is studying and analyzing some 340 Mesopotamian weights. Both students also worked with museum conservation staff on their projects. Conservator Laura D’Alessandro helped Tasha examine the surfaces of her coins to determine their composition and to attempt to read very worn surfaces under the microscope. Colleen made use of the laboratory’s microscope and the conservators’ expertise to examine hematite weights under low magnification to visually identify specific physical characteristics and burial contaminations that are not readily visible to the naked eye.

Registration also hosted visiting scholars Brian Muhs from Leiden University and Ursula Kaplony-Heckel of Marburg University, both of whom were here for three weeks in April to study some 600 Demotic ostraca, and Todd Hickey from Leuven and a colleague from Belgium, who examined nearly 1,900 Greek ostraca. These were only some of the major users of the collection in 1998/99. All told, those in Registration retrieved some 6,500 objects for research and academic purposes over the past year!

After due consideration, the Assyriologists in the building decided that the benefits of moving the tablet collection into a climate-controlled area outweighed the inconvenience of not having the material easily accessible on the third floor, and so, in the fall, the tablets were moved into new climate-controlled quarters in the basement. This entailed transporting 96 cabinets with nearly 500 drawers containing some 7,000 tablets, bullae, cones, and prisms, with as yet uncounted thousands of tablet casts. Ray and his volunteers are now in the process of inventorying the tablets and tablet casts and entering them in the registry database.

As the result of two IMLS Conservation Support Grants, the museum has been able to buy new state-of-the-art storage cabinets to house both the Mesopotamian and Megiddo collections. So, while the reinstallation of the Egyptian Gallery progressed and while scholars came and went, those in Registration also transferred the Mesopotamian collection from cardboard storage boxes to the new cabinets and are now working on unpacking Megiddo material, thus making these two important collections easily accessible for future study and exhibition.

During 1998/99, the museum received two generous gifts: jewelry from the estate of Mrs. John A. Wilson and a triptych in grisaille by Martyl from Dr. Wells and Alexandra Shoemaker.

And, despite everything else that was going on, those in Registration, Conservation, and Preparation enabled the museum to make two loans to important exhibitions. In January, the Kustul incense burner, our bronze statue of a Nubian king, and a ushebti belonging to Queen Amenirdis traveled to the Memphis Pink Palace Museum for an exhibition entitled *Africa's Egypt* that runs from February to September 1999. And four of our Old Kingdom servant statues and a stela fragment are traveling with the major Old Kingdom exhibition, *Egyptian Art at the Time of the Pyramids*, which just closed at the Grand Palais National in Paris, will open at the Metropolitan Museum of Art this fall, and will continue at the Royal Ontario Museum next spring. The Oriental Institute's servant statues seem to be great favorites among the many stunning objects in this exhibition and have been featured as postcards and in many articles.

All told, between unpacking and the requests of scholars, those in Registration moved over 20,000 objects last year, some of them many times. This would not have been possible without the help of many people. Ray extends his warmest thanks to the preparators and conservators; to registration intern Lauren Zych; to Anne Yanaway, who spent most of her afternoons acting as Ray's assistant; and, most particularly, to the very best corps of volunteers: Debbie Aliber, Leila Foster, Peggy Grant, Mary Grimshaw, Janet Helman, Georgie Maynard, Lillian Schwartz, Richard Watson, and Peggy Wick.

As a result of all this activity, over 500 objects passed through the Conservation Laboratory between July 1998 and the end of June 1999. Of these, approximately 338 were conserved in order to ready them for display in the new Egyptian Gallery. And one of the largest pieces, which didn't pass through the laboratory, but perhaps necessitated the most work, was the monumental statue of King Tut, which Conservation spent much of the late summer putting back together after its move into the new gallery (fig. 1).

In October, the first of our two Getty postgraduate conservation interns, Sara Caspi, joined Laura and Susan in the laboratory to begin her twelve-month internship. And it is a reminder of how time flies that the second internship has just been awarded. Laura sifted through twenty-one applications from a variety of countries (including Japan, Germany, Italy, Portugal, England, Canada, and the United States) before selecting Eric Nordgren, a recent graduate of the conservation program at the Institute of Archaeology, University College, London. Eric will be coming to the Oriental Institute after eighteen months postgraduate work experience at the National Museum of Beirut, Lebanon. Sara will be moving on this fall to the New York branch of the National Museum of the American Indian, where she has been awarded a Mellon Fellowship in Objects Conservation. We will miss her and wish her the best of success.

In May, the Women's Board of the University of Chicago awarded the museum a very generous grant to purchase equipment and analytical time for the new Conservation Laboratory. As a result, the Oriental Institute will soon have a Conservation Laboratory that measures up to the highest standards for such a facility, which is increasingly being used by faculty, staff, and students for teaching, research, and publication.

Publicity continued to be an important part of the museum's effort to remain in the public eye prior to reopening. Thanks to the continued support and indefatigable efforts of William Harms of the University News Office, working primarily with Emily, a well-timed, continuous stream of articles appeared in the *Chicago Tribune*, *Chicago Sun-Times*, and other major media, focusing on the relocation of the colossal statue of Tutankhamun and activities behind the scenes as we finalized the climate control systems and prepared the new gallery for the public. This sort of coverage is our primary means of keeping the Institute in the public eye, and the number of times that we appeared on the front page of the *Tribune* astounded, and delighted, us.

Far in advance of the opening of the new gallery, Emily and Bill Harms, assisted by Anne and Joe, prepared press packets that were sent to targeted media. A special press preview of the gallery was held on 27 May and was attended by approximately 50 representatives of local and national press. Each press representative had a name tag printed in hieroglyphs which, to our delight, proved to be of intense interest. At one point, the reporters were all comparing their badges to verify the phonetic values used in their names! Docent Mary Jo Khuri supplied beautifully decorated cookies in the form of mummies for the event, and docent guides were posted throughout the gallery to answer questions. The preparation paid off — in the course of the opening weekend more than fifteen features appeared on local and regional television and radio, including several live feeds from the gallery, a twenty minute segment on NPR, and an entire half-hour talk show devoted to the gallery. Important print stories appeared in *Minerva* and *KMT*, *Museum News*, *Home and Away* (the magazine of the American Automobile Association), and in places that we did not expect such as *Discover Magazine* and airline in-flight magazines. A major story in the *New York Times* brought another avalanche of national interest and wire service stories. The tremendous increase in visitations since the gallery reopening is certainly due in large part to this extensive press coverage.

Most of the time spent in the Oriental Institute Archives by John Larson and his volunteers during the year was devoted to unpacking and making selected parts of the collections more accessible for research. Priority is being given to material that will support the reinstallation of the museum galleries and serve the needs of both visiting scholars and researchers within the Oriental Institute's own community of scholars.

Although there are no new acquisitions in the Oriental Institute Archives to report for the current fiscal year, John and his volunteers have been making good use of material relating to the Medinet Habu ostraca studies of the late Professor Allen P. Wikgren, cited in last year's *Annual Report*. Returned to the Institute with the Wikgren Papers were 545 file photographs from the Oriental Institute Photographic Archives that had been on loan to Professor Wikgren since the 1940s. This set of photographs, which was believed to have been lost, is the principal documentary record of the Medinet Habu ostraca that was made at Chicago House prior to 1935, when the ostraca were packed up for shipment to Chicago for a long-term study loan. The original negatives, produced on large-format cellulose nitrate-based film stock that is considered to be an unstable material, were deliberately destroyed at Chicago House to eliminate their potential for spontaneous combustion during the

off-seasons when the staff is not in residence. The data associated with the Medinet Habu ostraca photographs has enabled John and his volunteers to develop a small but useful database that now has some 6,000 entries and is beginning to solve some of the vexing reference number problems that have affected work on the Medinet Habu ostraca for the past sixty-five years.

John is pleased to report that Peggy Grant and Mary Shea completed their long-term project to prepare word-processed text and digitally-scanned illustration figures from a draft manuscript of the late Professor Helene J. Kantor's unpublished dissertation on the development of plant ornament in ancient Near Eastern art. The manuscript, currently numbering 850 pages, has been posted on the Oriental Institute's website to serve as source material for interested scholars.

For 1998/99, the generous and enthusiastic volunteers working with John Larson in the Archives were Hazel Cramer, Lilian Cropsey, Patricia Hume, Sandra Jacobsohn, Janet Kessler, Lillian Schwartz, Helaine Staver, and Carole Yoshida. Since the beginning of the year, the Archives have been able to accommodate a small number of visiting scholars whose projects involve photographic research or a need for access to data from paper records in the Oriental Institute Archives. Without the dedication and good works of all of the Archives volunteers, John would never have been able to schedule such appointments so soon after the completion of our renovation project, and we all thank them warmly for their continuing efforts.

In addition to the regular Archives volunteers, Alison Carter, a student from Oberlin College in Ohio, volunteered in the Archives for two days a week during summer 1998 and one day a week during summer 1999. In May 1999, Margaret ("Meg") Dorman spent most of her "May Project" time near the end of her senior year in the Laboratory Schools high school assisting John in developing an image-based database for the Medinet Habu ostraca.

In the Museum Office, Anne prepared the necessary paperwork and handled other details involved in processing the requests received for photographic image

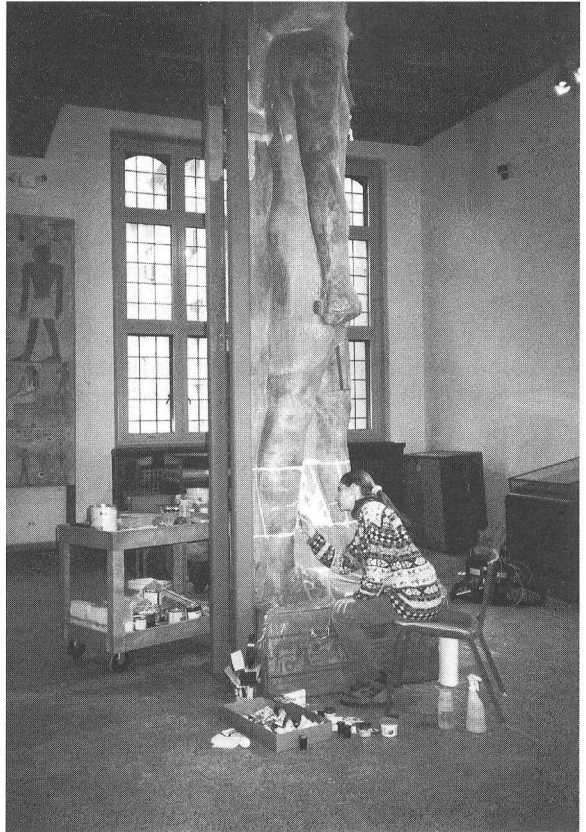

Figure 1. Getty Conservation Intern Sara Caspi works on the restoration of King Tut's legs

MUSEUM

materials and reproduction permissions — a total of 180 transactions during fiscal year 1998/99. She also answered a myriad of telephone calls about the reopening, kept track of all our orders, and looked over the University ledgers each month.

Head of Security, Margaret Schröder, and her guards spent yet another year keeping track of workmen and are busily trying to remember all the ins and outs of dealing with the public now that the museum is again open. Margaret also represented the Oriental Institute Museum at the Smithsonian/Getty Museum Conference on Cultural Property Protection in Los Angeles in late February.

Photographer extraordinaire Jean Grant spent most of 1998/99 getting her studio, office, and darkrooms back up and running. Jean would like to take this opportunity to thank high school freshman volunteer Mara Terras for being so willing to pitch in for scrubbing, repairing, hanging fixtures, and de-boxing, and to thank her stalwart “old-timers” Irene Glasner, Rea Ahlstrom, and Carole Yoshida for all their help.

Having completed the building project and finally reopened our doors to the public, we look forward to an exciting year of planning other new galleries and expect to have many new tales to tell in the next *Annual Report*.

MUSEUM EDUCATION

Carole Krucoff

Although the Oriental Institute galleries remained closed for most of this past year, each day brought us closer to the time when we could again share the treasures of our collection with visitors. The year was one filled with challenges and excitement as we simultaneously planned programming and events for the reopening of the Egyptian Gallery while continuing to offer a full schedule of educational services for adults, a wide variety of programs for children and their families, and a rich array of learning experiences for the Chicago Public Schools.

School and Teacher Services

For the last several years, the Polk Bros. Foundation has granted the Museum Education Department generous support to provide outreach and enrichment services for teachers and students in the Chicago Public Schools (CPS). Working in partnership with twenty-two schools located throughout the city, the Education Department has created a broad range of classroom curriculum resources and programs — including teacher and student materials and school outreach visits — that have enhanced the study of the ancient Near East for close to 10,000 CPS students.

With the museum scheduled to reopen during the 1998/99 school year, the Education Department and our partner schools sought and received Polk Bros. Foundation support for a new initiative — “Schools in the Museum: Integrating Classroom



Chicago Public School students meet Jesse Casana, graduate student in Near Eastern Archaeology, during a special "Schools in the Museum Program" field trip. This program is supported by the Polk Bros. Foundation. Photograph by Anna Rochester

and Museum Experiences." Anna Rochester, the Education Department's School and Teacher Services Coordinator, is supervising this new collaboration. The project is enabling her to experiment with ways the concepts and activities presented in the Oriental Institute's curriculum materials — which have replaced the traditional classroom textbook at many partner schools — can serve as a springboard for innovative and effective learning experiences in the newly reopened Egyptian Gallery. Such complete integration of classroom curricula with museum learning is unprecedented in the city of Chicago and may make a major impact on ways museums and schools work together to improve public education.

A talented artist and extraordinarily capable museum and classroom educator, Anna Rochester has been the driving force behind all of the Institute's museum-school partnership activities since 1997. For the "Schools in the Museum" project, a panel of CPS elementary-school teachers, curriculum coordinators, and administrators are working in collaboration with her. Panelists include: Lincoln Brown, Bret Harte School; Mary Cobb, Ray School; Richard Diaz, Field School; Mary McElroy, Donaghue School; Ingia Jackson, Sawyer School; Trish Ronan, Clissold School, Jeffrey Sadoff, Jackson School; Shirley Talley-Smith, Lafayette School, and Georgette White, Bass School. Two consultants are also helping to shape the program. Sara Spurlark, Associate Director of the University of Chicago's Center for School Improvement, has been guiding us with her wise council since 1993. Susan Stodolsky, Professor in the University's Departments of Education and Psychology, has joined us to serve as the "Schools in the Museum" program evaluator.

Anna was also involved in two additional grant-funded programs that have helped the Education Department expand its services to the Chicago Public Schools

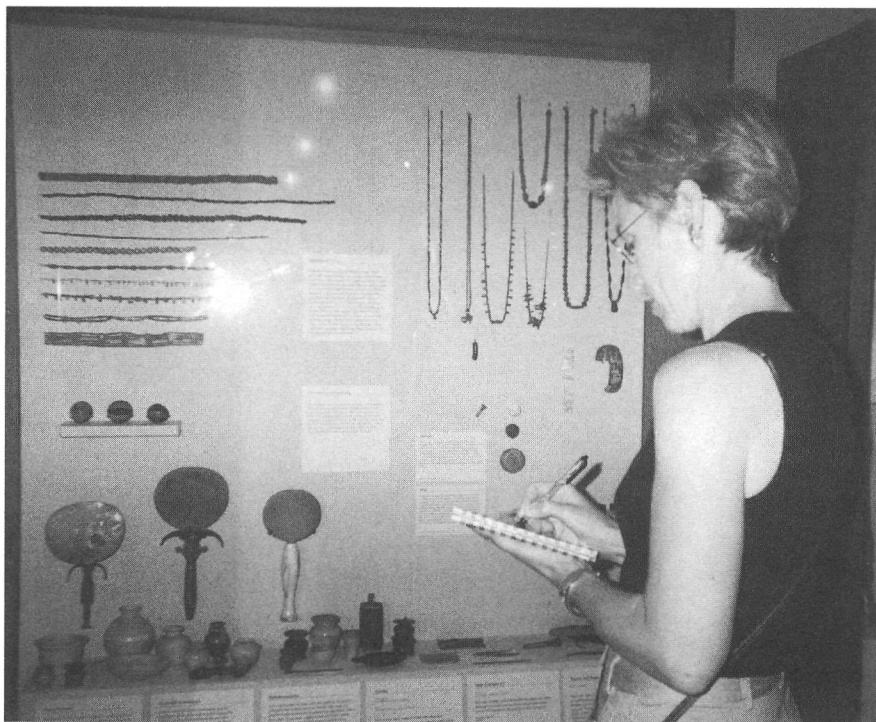

Mary Cobb, sixth-grade teacher at Ray School in Hyde Park, studies a display in the new Egyptian Gallery. Mary is a teacher-advisor for the "Schools in the Museum" partnership program supported by the Polk Bros. foundation. Photograph by Carole Krucoff

this year. Generous support from the Lloyd A. Fry Foundation allowed us to develop and pilot a teacher-training program on ancient Egypt and Nubia for CPS educators. Offered in partnership with the CPS Teachers' Academy for Professional Growth, the program rapidly filled to capacity as thirty-five teachers from twenty-nine different schools located throughout the city enrolled. Participants represented the gamut of CPS instruction, ranging from kindergarten teachers all the way to high school faculty, as well as literacy instructors, special education teachers, bilingual educators, curriculum coordinators, and even an elementary school librarian.

Designed to meet teachers' needs for both academic content and curriculum resources, the training program began with a series of lectures led by Oriental Institute faculty and staff, including: Peter Dorman, Associate Professor of Egyptology; John Larson, Oriental Institute Museum Archivist; Robert Ritner, Associate Professor of Egyptology; John Sanders, Head of the Computer Laboratory; Emily Teeter, Oriental Institute Associate Curator; Steve Vinson, Oriental Institute Research Associate; Karen L. Wilson, Oriental Institute Museum Director; and Frank Yurco. The lectures were followed by workshops that engaged the teachers in hands-on involvement with the Oriental Institute's array of curriculum materials on ancient Egypt and Nubia. These materials, originally developed over the past several years in collaboration with the museum's partner schools, include curriculum guides, full-color posters, maps, lesson plans, and replicas of museum artifacts. Used for the very first

time as teacher-training tools, these unique materials enabled seminar participants to relate the academic content of faculty lectures directly to specific teaching and learning strategies for the classroom. The success of this new program could be seen in the work produced by the teachers' students. Classroom projects ranged from travel brochures enticing tourists to journey back in time for a visit to the ancient Nubian city of Meroe — a fourth-grade class project — all the way to eleventh-grade honor students comparing and contrasting ancient Egyptian and medieval Anglo-Saxon literature. Examples from these and other student projects will be on view in a special Oriental Institute Museum display that opens this summer.

A grant from a generous local foundation is providing support to establish closer ties with sister institutions on campus and with our neighborhood public schools. Funding from the University of Chicago/Regents Park Fine Arts Partnership is enabling the Oriental Institute, Court Theater, University Theater, the University's Music Department, the Smart Museum of Art, and the Hyde Park Art Center to provide special educational enrichment programming for our community schools.

Working in collaboration with principals and teachers from Kenwood Academy and Ray and Bret Harte Schools, the Fine Arts Partnership Program has helped Museum Education offer experiences never before available for students. This past fall, 150 sixth-graders from Ray and Bret Harte sat spellbound during a lecture and video presentation by Mark Lehner, who was introduced to them as a leading authority on the pyramids and sphinx at Giza. Student letters to Lehner revealed the impact he had made. One boy thanked the archaeologist for "talking to us about what you do — it is probably something I will remember for the rest of my life." Other projects supported at Ray and Bret Harte included artist-in-residency programs where students learned how to create their own versions of ancient Nubian-style leatherwork and ancient Egyptian-style jewelry.

At Kenwood Academy, teacher Alice Mulberry's Latin



Docent Bernadette Strnad (center) introduces students from Crown Academy to King Tutankhamun. These Chicago Public School students toured the new Egyptian Gallery, thanks to a teacher-training project supported by the Lloyd A. Fry Foundation. Photograph by Jean Grant



A Kenwood Academy student rebuilds ancient-style pottery as part of an "Egypt in Roman Times" program presented for teacher Alice Mulberry's Latin classes. Photograph by Jean Grant

classes had special experiences based on their study of ancient Rome. Alexandra O'Brien, Near Eastern Languages and Civilizations Ph.D. candidate, presented a slide lecture on Egypt in Roman times. Then students tried their hand at rebuilding replicas of ancient-style pottery. The three-part program ended with a tour of the new Egyptian Gallery led by Associate Curator Emily Teeter, who focused on art and artifacts from Egypt's Roman period.

In the spring, the Oriental Institute joined with its University of Chicago/Regents Park Fine Arts Partnership colleagues to co-sponsor "Young at Art," a Sunday afternoon arts festival at Ida Noyes Hall showcasing partnership projects that had taken place during the school year. At the Oriental Institute's booth, school-residency artists Robert Gadowski and Anna Pertzoff fascinated children and their parents by inviting them to try ancient Nubian-style leatherwork or ancient Egyptian-style

metalworking. An evening Open House at Kenwood Academy showed families and friends the partnership's work with high school students.

The end of the school year brought the Museum Education Department closer to fulfilling a major goal. Last year, our partner school principals created the Oriental Institute Museum/CPS School Affiliates Program, a pilot project encouraging each school to contribute a modest fee so that partnership activities could continue throughout the school year. Principals were especially interested in retaining such services as school outreach visits by graduate students, who describe ways the Oriental Institute learns about the ancient past, and visits by Oriental Institute and community artists, who demonstrate and involve students in recreating ancient arts processes. Thanks to the Affiliates Program, our team of graduate students and artists could continue their outreach work. This year's team of graduate student visitors included Jesse Casana, Joseph Daniels, Nicole Hansen, Alexandra O'Brien, Jason Ur, and Justine Way. Artists included Elizabeth Cruger, Robert Gadowski, Randolph Olive, Anna Pertzoff, and Hardy Schlick. Their classroom visits were so well re-

ceived that principals voted to renew the Affiliates Program for the upcoming school year. Principals will also assist in expanding the program to additional schools. This means a structured system is now in place that can help school and teacher services endure and grow in the years to come.

Public Programs

Familiar favorites as well as new educational opportunities for the public filled the 1998/99 calendar. Adult education programs attracted 1,764 participants, an increase of 54% over last year. Programs for youth and families drew 1,650 children and their parents to museum events, both at the Institute and in partnership with sister institutions throughout the community. Year's end brought what we had all been waiting for — a grand celebration that attracted nearly 2,000 visitors to the museum for a three-day festival of programming to open the new Joseph and Mary Grimshaw Egyptian Gallery.

Adult Education Programs

Adult education took many formats this past year, serving participants who ranged from Hyde Park neighbors joining classes and programs offered at the Institute to correspondence and internet course registrants from across the nation and around the world.

Courses presented on campus included *Akhenhaten and the Amarna Age*, *Ancient Egyptian Society*, *Egypt at the Dawn of History*, and *Great Pyramids and Divine Kings*, all taught by Frank Yurco. *Islamic Art and Architecture*, which included a bus tour to see Islamic-style architecture in the Chicago area, was taught by Judith Pfeiffer. Michael Kozuh taught *From the Nile to the Indus: The Empire of the Ancient Persians*. Alexandra O'Brien was the instructor for *Women in Ancient Egypt*. Nicole Hansen taught *Ancient Lives: Tomb-Builders of the Pharaohs*. Steve Vinson was the instructor for *Ancient Mariners*.

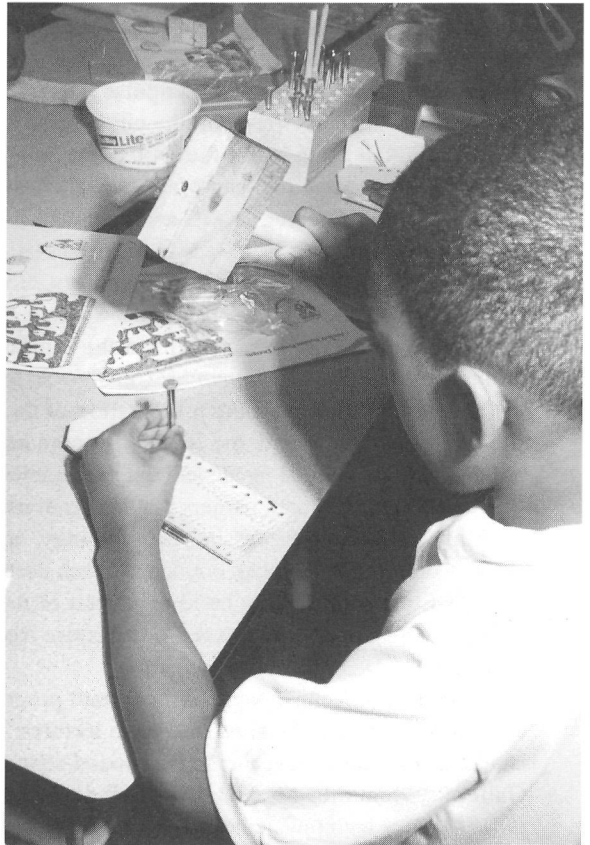

A sixth grade student from Bret Harte School decorates leather using ancient Nubian-style designs during an Oriental Institute arts-in-the-classroom program supported by the University of Chicago/Regents Park Arts Partnership. Photograph by Jean Grant

MUSEUM

Correspondence and audio-taped courses, as well as learning opportunities over the internet, all proved highly appealing this year. Nearly 100 participants, living in locations that ranged from Maine to California, enrolled in *Hieroglyphs by Mail*. Two sections of the course were offered, taught by Steve Vinson and Stephen Parker, with assistance from Thomas Dousa and Nicole Hansen. Frank Yurco continued his well-received series of audio-taped courses by presenting *Ancient Egyptian Law and Ethics, Part I*, followed by *Part II*. Student evaluations praised the format and content of the taped lectures, which are recordings of adult education class sessions held on campus. One student summarized the feelings of many when he wrote that “hearing the instructor and the class puts me right into the classroom ... it’s nice hearing the outside college bells, too.”

Internet instruction continued to reach a world-wide audience. Steve Vinson became an internet instructor this spring when he presented *Ancient Mariners On-Line*, an internet version of his on-campus class. John Sanders, Head of the Computer Laboratory, remains our mentor for all internet programs, which could not take place without his expertise, patience, and guidance.

Along with multi-session courses, adult education programs continued to be offered in a wide variety of formats. Field trips remained a favorite, with two highly regarded programs repeated by popular request. *Egypt in Chicago*, a one-day trip that presents insiders’ views on the city’s three major collections of ancient Egyptian art, sold out again — for the sixth time! Emily Teeter, Oriental Institute Associate Curator; Frank Yurco, and Mary Greuel, Research Associate in the Department of European and Decorative Arts and Sculpture and Classical Art at the Art Institute of Chicago, gave their usual masterful presentations. Egyptologist Michael Berger led his second presentation of *Egyptomania: Chicago-Style*, offered this time in collaboration with the Chicago Historical Society. A day-long bus tour that explores how Egyptian design has influenced the look of architectural and historic sites throughout the city, *Egyptomania: Chicago-Style* has come to have an unexpected but noteworthy impact on the preservation of the city’s architectural heritage. One site visited on the tour is the Reebie Storage and Moving Company, a northside building that is adorned inside and out with ancient Egyptian-style motifs. This past year, the Reebie building owners planned to drastically renovate the structure. Robert Ritner, Associate Professor of Egyptology, appeared before the Chicago Landmarks Commission to speak out against such destruction; his argument that the Oriental Institute had used the building as part of its educational programming helped influence the Commission to make the entire Reebie structure an official Chicago landmark.

Free public lectures were an important programming feature during the winter and spring. Emily Teeter presented two lectures: “Moving King Tut” described the challenge of transporting our 15,000 pound statue from the old to the new Egyptian Gallery; “Mummies Meet High Tech” described how today’s Egyptologists are joining forces with physicians to examine Egyptian mummies using the latest scientific techniques. Frank Yurco filled Breasted Hall with a lecture on “Fact and Fiction in the Biblical Book of Exodus,” which was co-sponsored by the Graham School of General Studies. Jill Carlotta Maher, Assistant to the Director of the Epigraphic Survey, presented “Rescuing Ancient Egypt,” a slide lecture on ways Chi-

ago House is struggling against time to record ancient inscriptions and carvings before environmental pressures destroy them forever.

Film programming presented a return engagement and some dramatic new options this year. Michael Berger brought back last season's *Ancient Egypt Goes Hollywood* for another look at ways the land of the pharaohs has been depicted in the movies. Several festivals of contemporary Middle Eastern films, which drew rave reviews from the metropolitan press, attracted an entirely new audience to Breasted Hall. Co-sponsored in a first-time collaboration with the University's Center for Middle Eastern Studies, the Language Laboratory and Archives, and the Newberger Hillel Center, the free festivals highlighted full-length feature films from Egypt, Lebanon, Israel, Turkey, and Iran. Film showings were followed by discussion sessions with cinema experts who volunteered their time to the program. Special thanks to Farouk Mustafa, Professional Lecturer in the Department of Near Eastern Languages and Civilizations, who served as discussion leader for the Arabic film festival, and to Louis Fishman, graduate student in the Department of Near Eastern Languages and Civilizations, who was the discussion leader for the Israeli Film Festival. Larry Wilson of Hillel helped organize the Israeli Festival. Mansooreh Saboori of the Center for Middle Eastern Studies worked on organizing the entire program. A documentary filmmaker from Iran, Mansooreh also served as the discussion leader for the Iranian Film Festival.



During our "Egyptomania: Chicago-Style" bus tour, participants saw these motifs adorning the Reebie Storage and Moving Company's building on the north side. The structure's use in Oriental Institute educational programming helped Associate Professor Robert Ritner convince the Chicago Landmarks Commission to give the Reebie building landmark status both inside and out. Photograph by Maybrit S. De Miranda

Youth and Family Programs

Designed to attract and serve a broad and diverse audience, programs for children and families benefit greatly from the Museum Education Department's collaborations with many partners, both on campus and throughout the community. This past year, we joined with Lill Street Studio on the north side for our third annual presentation of *Be an Ancient Egyptian Artist*, a week-long day camp for children ages 8–12. As before, this popular program sold out almost as soon as it was announced.

The fall season began with our annual return to the 57th Street Children's Book Fair, where Docent Kathy Mineck, her daughter Kristina, and her son Carl used



The Wild Swan Children's Theater Company of Ann Arbor, Michigan brought the myth of Isis and Osiris to life on the stage of Breasted Hall in May. Hundreds of children, parents, and teachers attended the theater company's three performances. Photograph by Jean Grant

hieroglyphs to highlight reading and writing ancient Egyptian-style. During the winter we joined forces with the Lincoln Park Zoo and the Field Museum to present *Ancient Animals*, a day-long program that introduced children and parents to actual species or close relatives of animals that were part of everyday life thousands of years ago. Also in winter we invited Professor Paul Sipiera of Harper College to present *Ancient Skywatchers*, a program that gave families a glimpse of the night sky as seen through the eyes of ancient astronomers.

In May, Museum Education presented its most ambitious family event to date — close to 600 children, parents, and teachers came to Breasted Hall to attend three performances of *Ancient Echoes: Tales From Egypt*, a dazzling children's theater production created by the Wild Swan Theater Company of Ann Arbor, Michigan. An original production, *Ancient Echoes* retold the ancient Egyptian myth of Isis and Osiris in a presentation that featured live music, dancers, puppetry, and extraordinary masks. The numbers of people attending the play would have overwhelmed us without the helping hands of fifteen volunteers who assisted with ticket sales, ushering, and crowd control. Our special thanks to Millicent Buchanan, Patty Dunkel, Bettie Dwinell, Gabrielle DaSilva, Debby Halpern, Mary Harter, Lee Herbst, Mary Irons, Janet Kessler, Elizabeth Lassers, Nina Longley, Adrienne Runge, Bernadette Strnad, Mike Toffel, and Jane Thain.

Hailed as professional children's theater at its very best, the Wild Swan Company is renowned for theater experiences that are accessible to all audiences. For its Oriental Institute presentations, the cast integrated sign-language interpretation into every scene, making the entire play accessible to the hearing impaired. Audio-interpretation was also available for children who were blind or visually impaired. These

special features encouraged funding organizations, as well as individual friends of the Oriental Institute, to offer their support for *Ancient Echoes*. Grants from the Midwest Arts Alliance's Heartland Arts Fund, supported in part by the National Endowment for the Arts; the Illinois Arts Council, a state agency; and the University of Chicago/Regents Park Fine Arts Partnership helped fund the presentation of the play. Generous donations from individuals also made *Ancient Echoes* possible. We gratefully thank Deborah Aliber, W. A. Boone, Nancy B. and Richard W. Baum, Muriel N. Brauer, Hazel Cramer, Bettie D. Dwinell, Barbara D. Frey, Anita Greenberg, Ernest A. Grunsfeld III, Cissy and Albert Haas, Mary Harter, Jane B. Hildebrand, Alice James, Samantha Johnson, George Junker, Mary Jo Khuri, Judy Licata, Masako Matsumoto, Georgianna Maynard, Denise G. Paul, JoAnn M. Putz, Lillian H. Schwartz, C. Lester Stermer, Marjorie G. Trosman, and Joyce Weil. All performances of *Ancient Echoes* honored the memory of Sally Grunsfeld, longtime Oriental Institute docent, friend, and supporter of Museum Education.

The Egyptian Gallery Reopens

While a full and varied schedule of educational activities has kept the museum in the public eye during closure, all of us in the Museum Education Office were counting the hours until we could share the Egyptian collection with visitors. For us, that opportunity came during two very special events — the preview opening for Orien-



Judy Barr Topinka, Illinois State Treasurer, offers words of welcome to the public attending the opening of the museum's Egyptian Gallery. A lifelong interest in ancient Egypt inspired her to attend the Egyptian Gallery opening. Photograph by Jean Grant

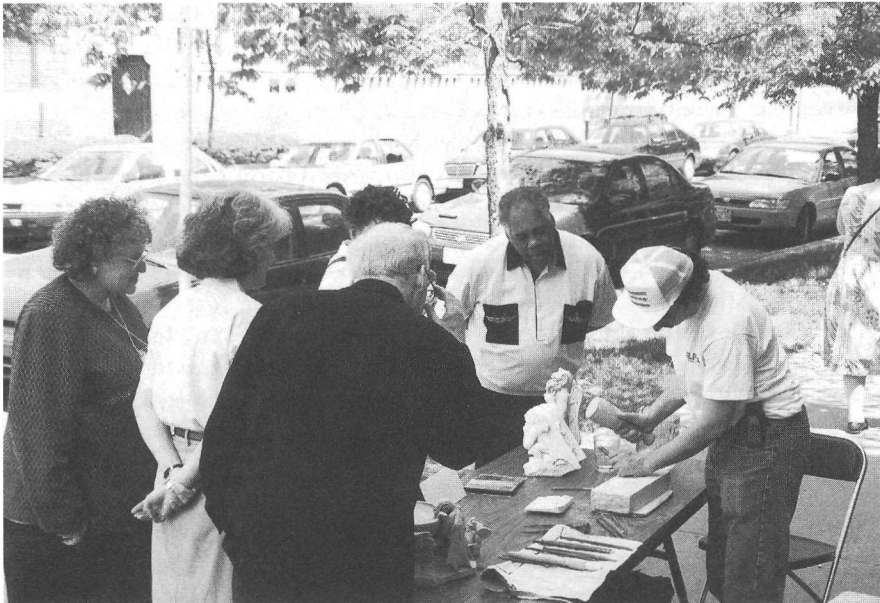

Left to right: Carole Krucoff, Head of Museum Education; Emily Teeter, Associate Curator, and Gene Gragg, Director, join fascinated visitors watching stoncarver Walter Arnold at work during "Celebrating Ancient Egypt," the weekend festival that opened the Egyptian Gallery to the public. Photograph by Jean Grant

tal Institute members on Sunday 23 May, and *Celebrating Ancient Egypt*, a three-day festival from 29 to 31 May that opened the Egyptian Gallery to the public. On both of these grand occasions, Education staff and volunteers, along with guest lecturers and presenters, were delighted hosts to crowds of enthusiastic visitors.

All who attended the openings were invited to take part in an exciting round of activities. Artist Walter Arnold demonstrated stoncarving using tools much like those on view in the Egyptian Gallery. Hardy Schlick showed how the ancient Egyptians made pottery and then invited everyone to create their own ancient-style wares. Egyptology students Carolyn Cracraft and Jennifer Westerfeld wrote names in hieroglyphs for what seemed like an unending stream of visitors. Dressed in Egyptian-style costumes, actresses Liz Cruger and Elena Dodge (who doubles as a graduate student in Islamic Archaeology) fascinated visitors with tales about mummies. Children — and their parents — could play ancient Egyptian board games, don Egyptian-style clothing from "King Tut's Closet," or bring themselves good luck by creating a reproduction amulet. The latest in documentary films on ancient Egypt played continuously in Breasted Hall; Emily Teeter lectured on the installation of the gallery; John Foster, Oriental Institute Research Associate, gave a reading of ancient Egyptian love poetry; and Illinois State Treasurer Judy Barr Topinka, who has had a lifelong interest in ancient Egypt, stopped by to congratulate the museum on its reopening.

An exhausted but happy Museum Education crew closed the doors on 31 May after serving as hosts to a three-day total of 1,924 visitors. Once again, such numbers would have been overwhelming without the support of twenty-two volunteers

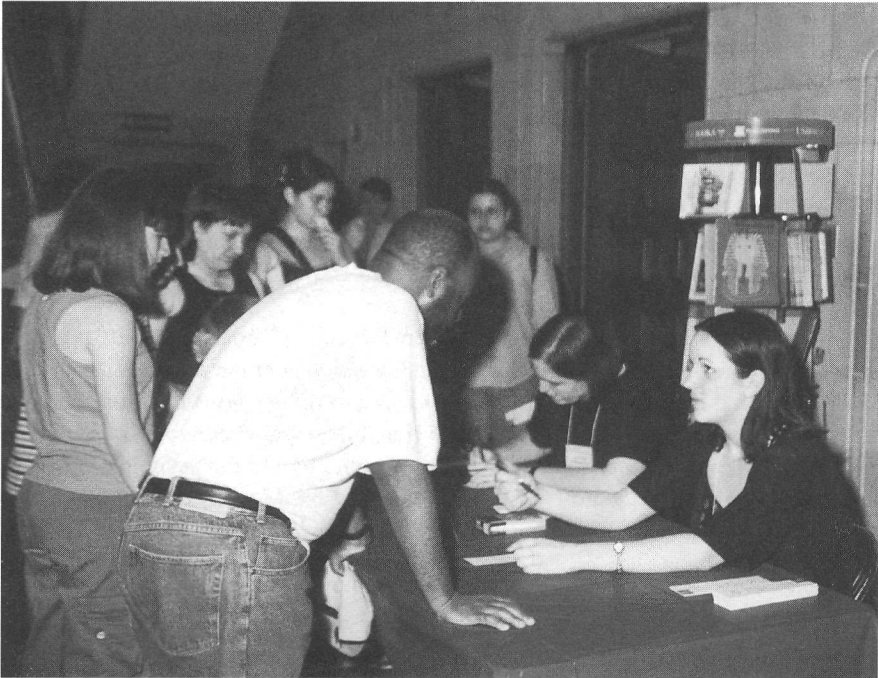

Egyptology students Jennifer Westerfeld (left) and Caroline Cracraft (right) wrote hundreds of names in ancient Egyptian hieroglyphs during the opening weekend for the new Egyptian Gallery. Photograph by Jean Grant

who spent long hours involving families in hands-on activities or answering the countless questions posed by Egyptian Gallery visitors. Our gratitude to Jane Belcher, Rebecca Binkley, Wanda Bolton, Millicent Buchanan, David Covill, Hazel Cramer, Nancy Gould, Teresa Hintzke, Pat Hume, Janet Kessler, Henriette Klawans, Ethan Longhenry, Georgie Maynard, George Morgan, Donald Payne, Stephen Ritzel, Adrienne Runge, Lucie Sandel, Lillian Schwartz, Bernadette Strnad, Karen Terras, Mike Toffel, and Maureen Toner.

Just a few weeks after our opening, the museum was filled to capacity once again when the Oriental Institute Museum joined with the Smart Museum of Art and the Hyde Park Art Center to present *Family Day*, an annual event that had a special flair this year since it took place on Father's Day. The Sunday afternoon program encouraged many Hyde Park neighbors to make their first visit to the reopened museum — close to 500 people came through the Egyptian Gallery during the three hours of the event. Along with visiting the gallery, children could make an Egyptian-style crown for their dads, have their faces painted with Egyptian designs, create a drawing on papyrus, or produce a family portrait. The Hyde Park Co-op donated refreshments as a Fathers' Day gift to the community.

Behind the Scenes

While what seemed like a whirlwind of activities defined Museum Education's public presence this past year, things were equally active "behind the scenes." Last

MUSEUM

summer we received word that a long-awaited move was about to take place — by September the Museum Education staff had settled into Room 221, the former locale of the Museum Archives, which now has its own climate-controlled space in the new wing. Room 221 is actually a “suite,” which means our space can be divided between the office and a new Conference Room and Docent Library. We’re delighted with our new facilities, but we couldn’t have moved without a lot of help. Special thanks to staff members Chuck Jones, John Larson, Randolph Olive, John Sanders, Joe Scott, Karen Wilson, and Anne Yanaway. Volunteers helped us, too. Many thanks to Todd Chavin, Mary and Richard Harter, Sandy Jacobsohn, Debbie Aliber, Daila Shefner, and Helaine Staver.

Even before moving into our new office, Education Department staff was hard at work meeting the demands of what would become one of our most exciting years. Two Education Programs Assistants were crucial to the implementation of all adult education programming in 1998/99. Emily Napolitano was Programs Assistant until December, when she received a well-deserved promotion to the position of Oriental Institute Membership Coordinator. While working for Museum Education, Emily supervised registration for all reserved programs, handled financial record keeping, assisted with graphic design, and provided general information services for the pub-



Emily Napolitano, Membership Coordinator, does ancient Egyptian-style face painting for a young visitor during “Family Day,” a special event co-sponsored by the Oriental Institute, the Smart Museum of Art, and the Hyde Park Art Center. Photograph by Jean Grant

lic, including the information that appears on the Museum Education page of the Oriental Institute's site on the World-Wide Web. Everyone in the Education Department appreciated Emily's efficiency and organizational skills, as well as her pleasant nature and genuine interest in educational services for the public. (Happily for us, Emily still occasionally assists with weekend programming, especially when the audience is young children — her favorite.)

Susy Giles became the Department's new Education Programs Assistant in February. A talented artist and arts educator, as well as an experienced office manager, Susy has become an invaluable member of the Education staff. All programming requiring registration would come to a grinding halt without her.

Much of the success of all our programs is due to the work of Judy Chavin, Education Programs Associate, who is our public relations officer, editor, and graphic design expert. Judy designs and supervises production of all our marketing and educational materials. This year, these included our quarterly calendars of events, adult education brochures, press packets for local newspapers, and the completely revised Docent Training Manual written by Emily Teeter. Judy's responsibilities also included developing a campaign of paid advertisements for a variety of community calendars and for selected local, regional, and national media. In addition, she kept careful watch for public events that would allow us to share information about our programs. This year, for the first time, we took part in Spotlight on Chicago, an annual event sponsored by the city of Chicago's Department of Cultural Affairs to showcase activities taking place at the city's cultural institutions. Judy is also serving as our liaison to Project Millennium, a year-long educational initiative, co-sponsored by 180 local and regional cultural institutions and museums. Designed to publicize the wide array of cultural opportunities available throughout the city and state, Project Millennium has introduced the museum's education programs to a broad range of new audiences.

Two interns generously donated their time to Museum Education during summer 1998, and each made lasting and important contributions. Danielle Sherrod interned with us for a second summer to complete a research project dear to her heart. An honors graduate student in anthropology from Harvard University, Danielle is also a talented dancer who came back to complete a research paper on ancient Egyptian dance. She hopes to present a dance program at the Oriental Institute based upon the outcomes of her research. Theresa Musacchio, an Egyptology student at Brown University, spent the summer working on a variety of projects. She provided invaluable assistance for the *Be an Ancient Egyptian Artist* day camp; she created a slide presentation that is a model for interactive learning with young children; and she developed an outline for a high school curriculum on ancient Egyptian literature.

Two extraordinarily talented, hardworking, and dedicated people deserve special mention here. Cathy Dueñas and Terry Friedman, the Oriental Institute's Volunteer Coordinators, along with their outstanding team of docents, were inspired by renovation to develop a hugely successful community outreach program that has the potential to enhance our educational services for years to come. As you will see in the next section, this past year Cathy and Terry continued to supervise and expand the outreach program while simultaneously recruiting and training our entire corps

MUSEUM

of volunteers to offer programs and services in our newly renovated museum. Congratulations to Cathy and Terry for all that they have accomplished.

Looking back on all that has taken place during the past year, I would like to express my appreciation for all the expertise, support, and encouragement that Museum Education has received from the Oriental Institute's faculty, staff, and students. Special thanks to the Docents for their willing assistance at every turn. To Bud Haas, our gratitude for your friendship, wise advice, and never-failing supply of innovative ideas. Finally, I offer my heartfelt thanks once again to the Education Office staff, who faced a demanding year filled with long hours and many unforeseen challenges. You overcame them all with great creativity, doing so with remarkable courtesy and consideration for each other and for the public that we serve. Your achievements are the best assurance of the Museum Education program's continued success.

VOLUNTEER PROGRAM

Catherine Dueñas and Terry Friedman

It has been a remarkable year for the Volunteer Program, one filled with significant growth and progress. With the announcement that the Joseph and Mary Grimshaw Egyptian Gallery would open in spring 1999, we carefully began to examine and evaluate the role of the Volunteer Program on the threshold of the twenty-first century. We saw our mission as twofold: encompassing past experience with future long-range strategies. Our first goal was to recruit, train, and introduce new members into the Volunteer Corps, while at the same time encouraging all current Volunteers, active and inactive, to renew their commitment to the Volunteer Program.

Our second goal was to keep the Outreach Program alive and vibrant, delivering substantive programming to an ever-expanding audience. With the Egyptian Gallery not scheduled to reopen until late spring 1999, Outreach continued to serve as a viable educational alternative, offering on-site as well as off-site field trip experiences. Outreach, with its versatile programs and diverse audience base, has become an integral part of the Volunteer Program over the past four years, helping to keep both the Volunteer Program and the museum alive and in the public eye throughout the period of gallery closure.

Volunteer Training

Fall was a very busy season for the Docents and Volunteers. Each Saturday from 10 October through 21 November, both returning and new Volunteers gathered in Breasted Hall to hear a series of lectures about ancient Egypt. The title of the training class was *Introducing Ancient Egypt* and it focused on the topics and themes that

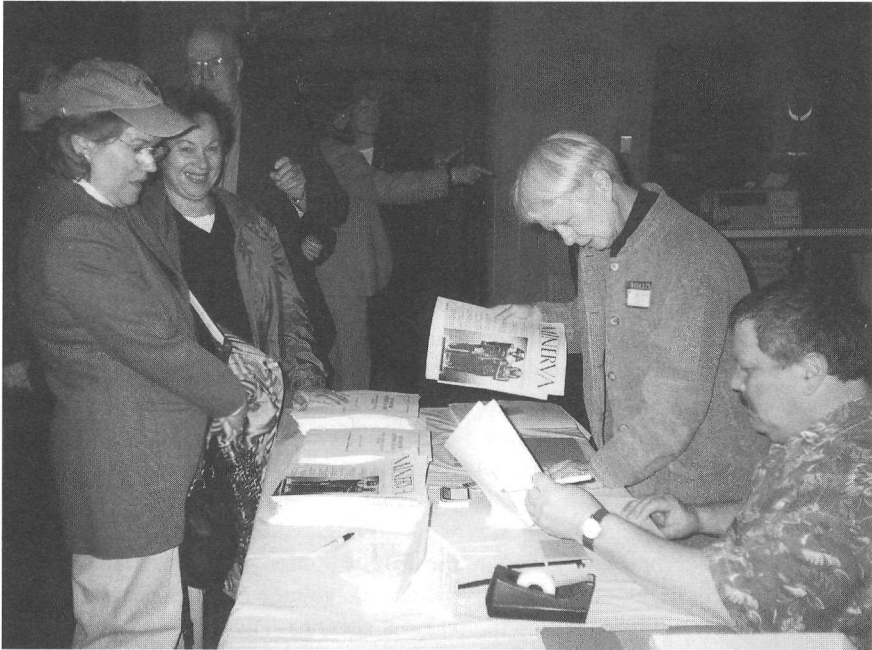

Debbie Aliber and Stephen Ritzel help Margaret Foorman and Deloris Sanders register during the May Volunteer Training Class Sessions. Photograph by Terry Friedman

would be presented in the new Egyptian Gallery. Afternoon break-out sessions focused attention on various volunteer options at the Oriental Institute.

The class was a successful collective effort that creatively combined new volunteers with experienced returning volunteers. We were also pleased to have the participation of many Chicago Public School teachers, who attended this class as part of an in-service training program funded by the Lloyd A. Fry Foundation. Their input provided a springboard for the discussion of important practical teaching techniques to enhance docent-led tours in the museum.

We would like to express our immense appreciation to everyone who worked on the Volunteer Training Class. Emily Teeter initiated and developed the themes and content of the Volunteer Class materials. Our thanks to the faculty and staff members, who gave nine dynamic lectures: Karen Wilson, Peter Dorman, Frank Yurco, Emily Teeter, John Larson, Robert Ritner, Steve Vinson, and John Sanders.

Special thanks to those who worked on the Volunteer Training Manual. Emily Teeter, curator of the Egyptian Gallery, wrote the Training Manual, and Judy Chavin, Carole Krucoff, John Larson, and Karen Wilson made helpful editing additions. The end result produced an excellent instructional tool for the new Egyptian Gallery.

We are grateful to the volunteers who enriched training by presenting very interesting break-out sessions to the class participants: For "What An Archaeologist Does," thanks to Bud Haas, Evelyn Ruskin, and Larry Scheff; for the "Mock Outreach Break-out Session," thanks to Janet Calkins, Hazel Cramer, Masako Matsumoto, Diane Posner, Stephen Ritzel, Deloris Sanders, and Carole Yoshida; for

MUSEUM

“Reading Egyptian Hieroglyphs,” thanks to George Junker; and for “Museum Education at the Oriental Institute,” thanks to Carole Krucoff.

Last, but certainly not least, our thanks to the many volunteers who shared their talents and organizational skills to help make the class sessions run smoothly. These were the volunteers who faithfully assisted with setup, registration, and cleanup throughout the entire series: Debbie Aliber, Hazel Cramer, Peggy Grant, Masako Matsumoto, Denise Paul, Diane Posner, Stephen Ritzel, Christina Ruhaak, and Carole Yoshida.

Follow-up Training Sessions

On 8 May and 15 May, two follow-up training sessions were offered to prepare the volunteers to give docent-led tours of the new Egyptian Gallery. Emily Teeter, curator of the Egyptian Gallery, led these two additional training sessions for the docents and volunteers. The themes and objects on view in the new Egyptian Gallery were beautifully presented to the volunteers using slides and a discussion format to help familiarize everyone with the gallery content.

The afternoon activities on 8 May were highlighted by the video “Docent on Tour,” which was produced by the Smithsonian Institution. After viewing this special video, which discusses touring techniques, the volunteers and several Chicago Public School teachers participated in break-out sessions. These sessions resulted in some excellent ideas for interactive touring techniques, which docents will be able to use with visiting school groups in the museum.

The 15 May afternoon session featured Sheldon Newman, a professional training consultant. Mr. Newman was introduced to the Oriental Institute through a recruitment advertisement for new volunteers posted on the website. Although he was unable to participate in the training class, he was pleased to offer his services as a training consultant. With the opening of the new Egyptian Gallery on the horizon, he wanted to develop a special program that would give the volunteers an opportunity to discuss their concerns as well as to create an open forum for dialogue about their role and responsibilities as tour guides in the new Egyptian Gallery. The second part of the afternoon program allowed everyone to join break-out session groups to brainstorm and work creatively on producing problem-solving techniques. The end result was a fascinating exchange of useful ideas.

Our New Office Space

Finally in September, after months of planning and preparation, we moved into our spacious new office in Room 221. Our thanks and appreciation to the many volunteers who helped facilitate the move and who participated in the organization throughout this important transition. Hats off to Debbie Aliber, Todd Chavin, Mary and Richard Harter, Sandy Jacobsohn, Daila Shefner, and Helaine Staver. Special thanks to Oriental Institute staff members Randolph Olive and Joe Scott, who helped us move and install the book shelves in the Docent Library; and to John Sanders who graciously moved and installed our computers, printer, and telephones. Thank you all. We could never have done it without your help.



Volunteers Mari Terman, George Morgan, and Carole Yoshida relax and enjoy coffee and conversation in the new Docent Library and Education Office conference room. Photograph by Terry Friedman

Library

This year the Docent Library has continued to expand and flourish under the supervision of the Docent Librarian, Debbie Aliber, and her library committee: Sandy Jacobsohn, Deloris Sanders, and Daila Shefner. Special thanks to all of them for continuing to maintain this wonderful educational resource for the docents and volunteers.

The Docent Library has also received many generous book donations and gifts from faculty, staff, and volunteers. We were very honored to receive a special contribution from the South Suburban Archaeological Society in memory of Barbara James.

As a result of our move into the Education Office Suite in Room 221, the library is now housed in a comfortable conference room, adjacent to the Museum Education Office. Docents and volunteers can come in to enjoy a cup of coffee, have lunch, or just read quietly in this new space.

Docent Days

Volunteers enthusiastically attended and participated in Docent Day programs and activities throughout this past year. With the construction phase of the renovation



Volunteers Helaine Staver, Rochelle Rossin, Mary Grimshaw, and Lillian Schwartz watch attentively as Virginia Heaven, Curator of the Haifa Faisal Collection, discusses some of the beautiful textiles from Saudia Arabia. Photograph by Terry Friedman

project completed, the volunteers were able to return to Breasted Hall to hear a variety of fascinating lectures. We would like to express our appreciation to the members of the faculty, staff, and to the volunteers who provided enriching learning experiences for us all: Abbas Alizadeh, John Brinkman, Norman Golb, Martha Roth, Matthew Stolper, Emily Teeter, Aslihan Yener, Tim Cashion, Larry Scheff, and Mary Shea. We would like to thank everyone for making our Docent Days very rewarding.

Field Trips

Volunteers enjoyed the opportunity to visit three culturally diverse and unique art collections on their field trips this year. These excursions served as thought-provoking and enlightening educational experiences. They highlighted intriguing collections and enhanced our appreciation of a wide variety of art forms. Our thanks to Virginia Heaven of the Haifa Faisal Collection; Ned Broderick, Joe Petrocelli, and Sondra Varco of the National Vietnam Veterans Art Museum; and to Bob Cantu, Frank Yurco, and Docent Larry Scheff of the Field Museum for inviting the volunteers to visit these wonderful educational resources in the City of Chicago.

Interns

We were delighted this year to have the opportunity to work with three energetic and motivated interns who assisted the Volunteer Program in many ways. Christina Ruhaak, who came to us from Skidmore College; Emily Schuttenberg from the University of Chicago Laboratory Schools; and Michael Tafel from the University of Il-

Illinois at Chicago. From administrative tasks to Outreach Programs, their youthful energy and creative spirit has added so much to the Volunteer Program. We thank them for their time and commitment to the Oriental Institute.

Graduation, Volunteer Recognition, and the Annual Holiday Luncheon

On 9 December, faculty, staff, and volunteers gathered to enjoy a festive celebration for December Docent Day, which featured Volunteer Training Graduation, Volunteer Recognition Ceremonies, and a lovely Holiday Luncheon.

Our guest speaker for the morning program was Professor Norman Golb, who discussed "What's New With the Dead Sea Scrolls." It was a fascinating update that highlighted some of the historical background, discovery, and controversial interpretation of the scrolls. The morning's activities culminated with the Volunteer Recognition Ceremony.

Welcome Aboard to the Class of 1998

Congratulations to our thirty-three new graduates. This was the largest graduating class in the thirty-two year history of the Volunteer Program.

Following the lecture, the program continued with the introduction of the 1998 graduating class of new volunteers and the recognition of the multi-year honorees:

Class of 1998

Wanda Bolton	Pat Hume	George Morgan
Lyla Bradley	Mary Irons	Alyda Nicholson
Myllicent Buchanan	Maryam Keshavarz	Donald Payne
Alexandra Cordts	Janet Kessler	Christina Ruhaak
Dave Covill	Henriette Klawans	Kate San Fratello
Genevieve Daniels	Patrick Klimczyk	Lucie Sandel
James Davis	Charles Lang	Caroline Taylor
Patty Dunkel	Elizabeth Lassers	Mari Terman
Nancy Gould	Judy Licata	Karen Terras
Deborah Halpern	Robert McGinness	Maureen Toner
Lee Herbst	Pat McLaughlin	Joyce Weil

5 Year Honorees

Bernadine Basile	Evelyn Ruskin	Denise Paul
Jane Belcher	Ira Hardman	Diane Posner
Erl Dordal	Carole Krucoff	Deloris Sanders
Bettie Dwinell	Johanna Lucas	Bernadette Strnad
Irene Glasner	Roy Miller	Annette Teaney
Kaylin Goldstein	Kathy Mineck	Jane Thain

10 Year Honorees

William Boone	John Gay	Mary Grimshaw	Daila Shefner
---------------	----------	---------------	---------------

15 Year Honorees

Melanie Petrosky

Carole Yoshida

20 Year Honorees

Muriel Brauer

Janet Helman

Peggy Kovacs

Anita Greenberg

Marsha Holden

Norma van der Meulen

25 Year Honoree

Sally Grunsfeld

Bravo and congratulations to the class of 1998 and all honorees.

With the conclusion of the morning program, the docents and volunteers were invited to join the faculty and staff of the Oriental Institute for a delicious catered luncheon at the Quadrangle Club. Our thanks and appreciation to Director Gene Gragg for graciously underwriting this festive occasion and to Tim Cashion and the Development Office for providing complimentary memberships to all the Recognition Award recipients. We would also like to give a special note of thanks to Jean Grant for taking memorable photographs of the day's events.

January Tea at the President's Home

In January, the faculty, staff, and volunteers were graciously welcomed at the home of President and Mrs. Sonnenschein for a "fireside chat" and a lovely tea reception. Despite the inclement weather, a dedicated group of faculty, staff, and volunteers



Volunteers gather at the home of President and Mrs. Sonnenschein for a lovely tea reception and fireside chat. Mary Harter serves tea to Oriental Institute Director Professor Gene Gragg, our guest speaker for the occasion. Photograph by Jean Grant

gathered to hear Professor Gene Gragg speak about "The Oriental Institute and Its Museum." Professor Gragg gave an interesting historical retrospective concerning the background of the Oriental Institute and its founder, James Henry Breasted. His talk focused on Breasted's definition of purpose and projected future goals for the Oriental Institute and its museum. Professor Gragg's presentation also discussed some of the intricate architectural details of the building, highlighting such items as the tympanum over the entrance to the Institute.

Outreach

Volunteers have enthusiastically continued to embrace the Outreach Program, devoting their time and energies to producing and presenting unique interactive learning experiences for a variety of audiences throughout metropolitan Chicago, Indiana,

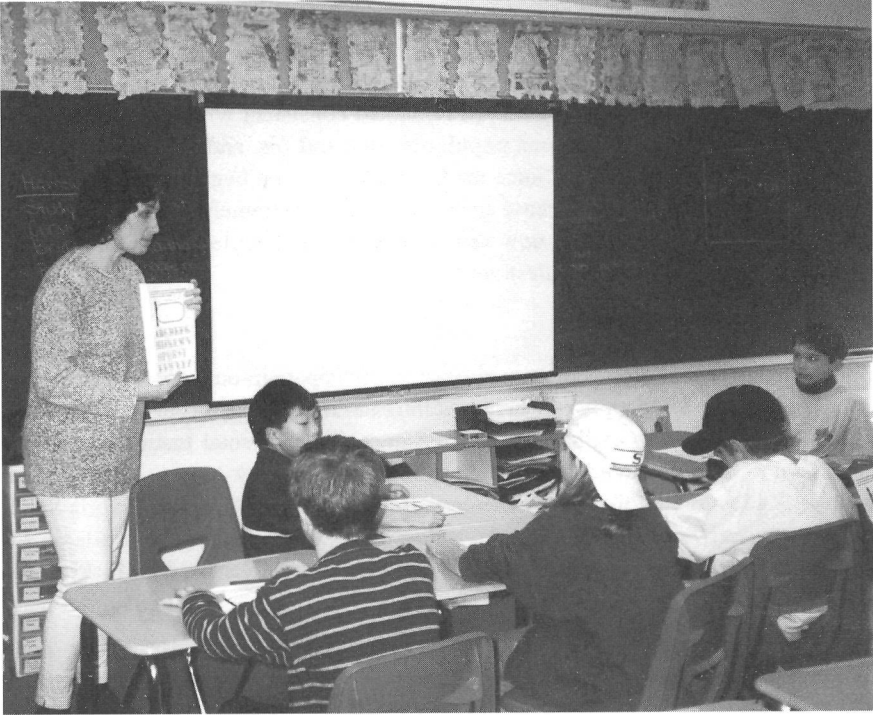

Debby Halpern helps fourth graders learn more about Egyptian hieroglyphs during a visit to Francis Parker School. Photograph by Terry Friedman



At an outreach visit to Francis Parker School, fourth graders pretend to be ancient pharaohs and princesses. Photograph by Terry Friedman

MUSEUM

Michigan, and Wisconsin. Outreach has continued to be the vital link in helping the Institute stay “in the public eye” during the period of renovation. The program’s content and execution brought history and archaeology alive to participants young and old. The numbers of people served remained consistent with last year’s statistics, demonstrating the continued popularity, demand for, and importance of this valuable educational resource. Since the Outreach Program began in 1995, requests for visits have continued to increase each year. We are extremely proud to announce that the Outreach Program has now served over 10,000 people. Bravo to everyone who has helped us reach this milestone.

Elderhostel

During this past year, we were very pleased to participate in our second Elderhostel Program with the University of Chicago’s International House. From 10 to 14 May, Elderhostel participants explored “The Treasures of the Oriental Institute.” Our appreciation to all the volunteers who helped to make the week-long program a great success. Kudos to the following presenters: Bud Haas, Janet Helman, Deloris Sanders, Larry Scheff, and Carole Yoshida, and to those who assisted with hands-on activities: Debbie Aliber, Debby Halpern, Mary Harter, Lee Herbst, Rita Picken, and Rochelle Rossin.



Lee Herbst, Rita Picken, and Cathy Dueñas greet Elderhostel participants during a week-long program that highlighted the “Treasures of the Oriental Institute.” Photograph by Terry Friedman

Donations

We have been very fortunate to receive many generous financial and in-kind contributions from volunteers and supporters this past year.

Contributors to the Docent Program have included William Boone, Mary D'Ouille, Bettie Dwinell, Margaret Foorman (in memory of Sally Grunsfeld), Peggy Kovacs, Rochelle Rossin, and Eleanor Swift (in memory of Ida DePencier)

A special note of appreciation to Volunteer Emeritus Betty Baum for her generosity. Her gift provided the funds to purchase a state-of-the-art laser printer for the Volunteer and Education Office.

In Memoriam

This year the Volunteer Program lost three loyal friends and supporters: Ida DePencier, Sally Grunsfeld, and Sally Zimmerman. Collectively, these extraordinary women devoted over 75 years of service to the Oriental Institute and to its Volunteer Program. All of these women were wonderful role models who exemplified a spirit of intellectual curiosity, learning, and generosity. We will miss all of them greatly.

Opening of the Egyptian Gallery

May was certainly an historic month for the Oriental Institute Museum. For over three years, visitors had waited patiently for the new Grimshaw Egyptian Gallery to reopen. The official public opening took place over Memorial Day weekend, 29–31 May. Nearly 2,000 visitors came through the doors to see “Egypt Unveiled” and to view the artifacts in the beautiful new gallery space. Volunteers were stationed in the Egyptian Gallery to serve as “Ask Me Docents,” helping greet museum visitors, answering questions, and assisting with planned activities in other areas of the building. A steady flow of enthusiastic visitors, from senior citizens to children in strollers, were impressed with the majestic beauty of this world-renowned collection and were thrilled to participate in the activities involving this momentous opening.

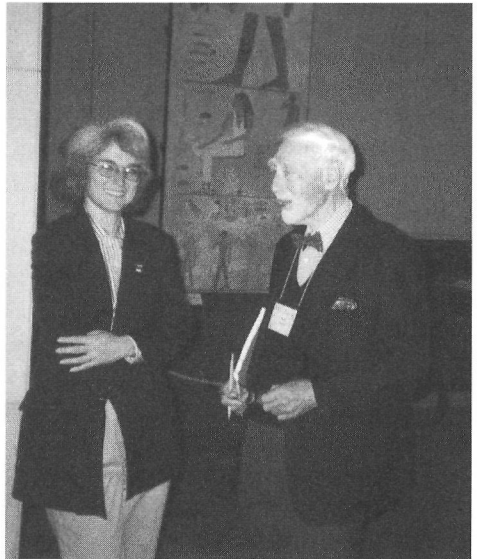

Volunteer Bud Haas stops to congratulate Emily Teeter, curator of the Egyptian Gallery, during the members' preview weekend. Photograph by Catherine Dueñas

In Retrospect

The Docent and Volunteer Program is poised and ready to accept the challenges that it faces in the 21st century. Throughout its thirty-three year history, the program has been able to adapt and change with the times. The closing of the museum and the development of a successful Outreach Program has taught us how resilient and resourceful the Volunteer Program can be.

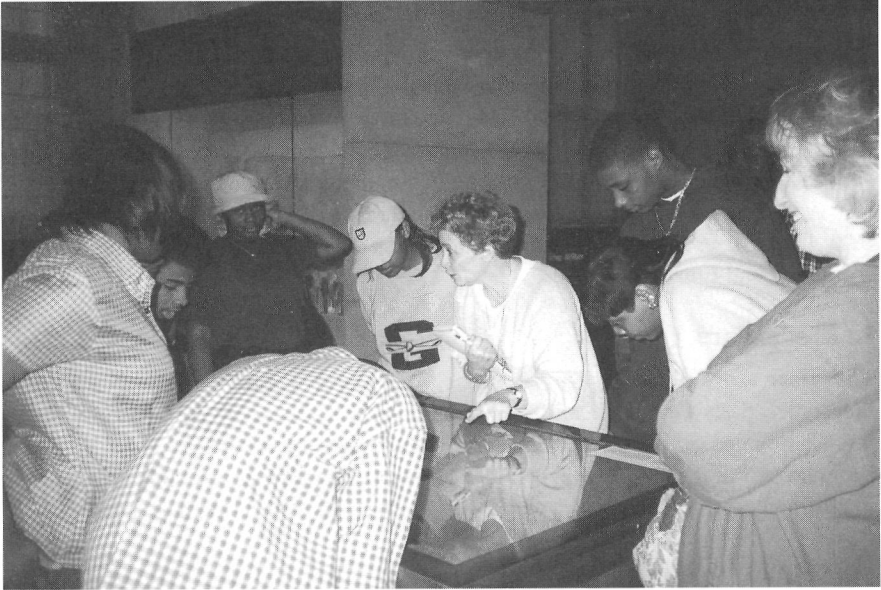

Evelyn Ruskin gives one of the first docent-led tours of the Egyptian Gallery to students from Carver Academy. Carver students visited the museum through a program funded by the Lloyd A. Fry Foundation. Photograph by Terry Friedman

We are grateful to the faculty and staff of the Oriental Institute for their support and friendship throughout the years. As our teachers and mentors, they continue to share their wealth of knowledge, sparking our curiosity and supplying countless resources for our ongoing continuing education. The accessibility and involvement of both faculty and staff in the Volunteer Program help to motivate and inspire the high level of docent and volunteer commitment throughout many vital areas of the Oriental Institute and the museum.

We would like to thank our colleagues in Museum Education, Judy Chavin, Susy Giles, Carole Krucoff, Emily Napolitano, and Anna Rochester, for their guidance and faithful support throughout this past year.

In conclusion, the Docent and Volunteer Program is well prepared to meet the challenges of the twenty-first century. The Volunteers are the Institute's most valuable asset. Whether working behind the scenes, assisting with research, doing outreach, or guiding in the museum, their creativity, tenacity, and unwavering support are an inspiration to all. We thank them for their many contributions, we admire their numerous talents, and we take pride in all they have accomplished.

Advisors to Volunteer Program

Carlotta Maher Peggy Grant Janet Helman

Honorary Volunteer-At-Large

Elizabeth Sonnenschein

Museum Docents and Outreach Volunteers

Debbie Aliber	Richard Harter	Pat McLaughlin
Bernadine Basile	Janet Helman	Denise Paul
Jane Belcher	Lee Herbst	Kitty Picken
Rebecca Binkley	Teresa Hintzke	Rita Picken
Dorothy Blindt	Patricia Hume	Diane Posner
Richard Blindt	Alice James	Dawn Prena
Wanda Bolton	George Junker	Stephen Ritzel
Myllicent Buchanan	Jeanne Junker	Adrienne Runge
Janet Calkins	Maryam Keshavarz	Laura Sanchez
Hazel Cramer	Mary Jo Khuri	Deloris Sanders
Lilian Cropsey	Henriette Klawans	Larry Scheff
Erl Dordal	Betsy Kremers	Anne Schumacher
Bettie Dwinell	Nina Longley	Daila Shefner
Margaret Foorman	Jo Lucas	Bernie Shelly
Evelyn Fuskin	Kay Matsumoto	Helaine Staver
Bud Haas	Georgie Maynard	Bernadette Strnad
Cissy Haas	Roy Miller	Mari Terman
Debby Halpern	Kathy Mineck	Karen Terras
Ira Hardman	George Morgan	Mauren Toner
Mary Harter	Caryl Mikrut	Carole Yoshida

Museum Education and Family Programs Volunteers

Ethan Longhenry	Danielle Sherrod
Kathy, Kristen, and Carl Mineck	Jane Thain
Theresa Musacchio	Mara Terras

Suq Docents

Barbara Storms Baird	Ruth Hyman	Rochelle Rossin
Muriel Brauer	Peggy Kovacs	Mary Schulman
Meg Dorman	Elizabeth Lassers	Jane Thain
Patty Dunkel	Georgie Maynard	Norma van der Meulen
Barbara Frey	Agnethe Rattenborg	Felicia Whitcomb
Peggy Grant		

Substitute Suq Docents

Janet Helman Jo Jackson

Suq Behind-the-Scenes Docent

Georgie Maynard

Suq Jewelry Designer

Norma van der Meulen

Suq Office and Stock Room Volunteers

Georgie Maynard Eleanor Swift

MUSEUM**Membership and Development Volunteers**

Debbie Aliber	Mary Grimshaw	Carlotta Maher
Peggy Grant	Bud Haas	

Volunteers Assisting with American Research Center in Egypt Conference

Rebecca Binkley	Lee Herbst	Felicia and John Whitcomb
Meg Dorman	Kay Matsumoto	Carole Yoshida
Bettie Dwinell	Georgie Maynard	
Debby Halpern	Rita and Kitty Picken	

Volunteers Assisting with the Theban Workshop

Pat Hume Bernadette Strnad

Museum Archives Volunteers

Hazel Cramer	Sandra Jacobsohn	Mary Shea
Peggy Grant	Janet Zell Kessler	Helaine Staver
Patricia Hume	Lillian Schwartz	Carole Yoshida

Registrar's Office Volunteers

Debbie Aliber	Mary Grimshaw	Lillian Schwartz
Leila Foster	Janet Helman	Dick Watson
Peggy Grant	Georgie Maynard	Peggy Wick

Diyala Project Volunteers

Richard Harter	Helaine Staver	Carole Yoshida
Betsy Kremers	Joyce Weil	

Medinet Habu Project

Hazel Cramer Peggy Grant Mary Harter

Göltepe/Kestel Project and Amuq Valley Regional Project

Joan Friedmann Bud Haas Betsy Kremers Daila Shefner

Photography Laboratory Volunteers

Maria Ahlstrom	Hugh Christ	Dawn Prena	Carole Yoshida
Debbie Aliber	Irene Glasner	Mara Terras	

Computer Laboratory Volunteers

Lyla Bradley	Nancy Gould	Karen Terras
Irv Diamond	Peggy Grant	Robert Randolph
Irene Glasner	Richard Harter	Les Stermer

Conservation Laboratory Volunteer

Vilma Basilissi

Docent Library

Head Librarian - Debbie Aliber

Assistant Librarians

Lillian Cropsey	Jo Jackson	Kathy Mineck
Peggy Grant	Sandra Jacobsohn	Deloris Sanders
Patricia Hume	Georgie Maynard	Daila Shefner

Ceramic Restoration

Elizabeth Tieken

Assistants to Epigraphic Survey and Chicago House

Carlotta Maher Crennan Ray Elinor Smith

Assistants to the Prehistoric Project

Diana Grodzins Andree Wood

Hittite Dictionary Project Volunteers

Irv Diamond	Kathy Mineck	Anne Schumacher
Irene Glasner	Denise Paul	

Readers for Professor Emeritus Hans Güterbock

George Junker Anne Schumacher

Publications

Irv Diamond Roy Miller

Publications - *The Demotic Verbal System*

Ruth Caraher	Denise Paul	Tom Dousa
Irene Glasner	Kathy Mineck	Irv Diamond

Iranian Prehistoric Project Volunteer

Janet Helman

Volunteers Emeritus

Elizabeth Baum	Laurie Fish	Eleanor Swift
William Boone	Charlotte Collier	Carol Green
Vida Wentz	Mary D'Ouille	Sally Grunsfeld†
Sally Zimmerman†	Ida DePencier†	Dorothy Mozinski

†Deceased 1998 and 1999

SUQ

Denise Browning

Thanks to a very generous donation, this year has been an exciting one for the Suq with the start of our own renovation! The entire store was gutted, the walls lined with fabric covered homosote and hidden stantions for shelving, and the ceiling raised to the same height as the lobby giving us a much more open feeling to our tiny space, and eventually a place to hang some of our rugs. The homosote has some of the properties of cork board, allowing us to easily hang merchandise all over the store like a real Near Eastern suq. Still to be installed are the track lighting, a new jewelry case, and a new cash register station. Most of the work thankfully was completed in time for the opening of our new Egyptian Gallery.

This year we once again were involved in the Newberry Library's Very Merry Bazaar. Thanks to all of those that helped: Barbara Baird, Natalia Uribe, Amy Hoffsheir, and Margaret Schröder.

Unfortunately this year is the last for Barbara Frey since she will be moving to Florida full-time. She has given many years of service to the Suq and we will miss her.

Our Holiday sale and our year end inventory sale were very successful this year. We sold over seventy rugs during the inventory sale!

Many thanks to all of our loyal docents who have helped make our success possible and who have so cheerfully greeted all of our new customers with the opening of the Egyptian Gallery. Thanks to Florence Ovidia for making our Suq beautiful, to Georgie Maynard for keeping our books stocked, and to our student office staff: Amy Hoffsheir, Holly Warren, Jo Anna Lee, and Susan Atkin. A special thanks to Norma van der Meulen who has designed many beautiful pieces of jewelry for our store. Also, thanks to Muriel and Jerry Brauer who opened their home to me in San Francisco, so that I was able to attend the San Francisco gift show to bring some wonderful merchandise back to the Suq. I even found some modern hand cut cylinder seals!

Docents - Loyal Regulars

Muriel Brauer	Georgie Maynard
Patty Dunkel	Norma van der Meulen
Barbara Frey	Agnethe Rattenborg
Peggy Grant	Rochelle Rossin
Ruth Hyman	Mary Schulman
Peggy Kovacs	Jane Thain
Elizabeth Lassers	

Docents - Loyal Extras

Barbara Storms Baird	Eleanor Swift
Meg Dorman	Felicia Whitcomb
Janet Helman	John Whitcomb
Jo Jackson	

THE ORIENTAL INSTITUTE CAMPAIGN

On July 17, 1966, the City of Chicago, through the Oriental Institute, unveiled this plaque to commemorate the completion of the Oriental Institute's Legacy Campaign for expansion and renovation. The Oriental Institute is grateful to the donors for the gift of several anonymous gifts and the following named gifts, foundations and corporations:

\$100,000 and Above

- Elizabeth Baum
- Ebbers M. Becker
- Robert and Sally Brooker
- The Chicago Community Trust
- Anthony and Lawrie Dean
- Ernst & Young LLP
- Margaret Flender Ewing
- Elizabeth Morse Charitable Trust
- Elizabeth Morse Genius Charitable Trust
- Dr. Marjorie M. Fisher
- Mr. and Mrs. Joseph N. Gilmahaw
- Dr. Henrietta M. Herbolzheimer
- Marshall and Doris Holleb
- Alice Irwin
- The LaSalle Banks
- David and Carlotta Maher
- Morgan Stanley & Co. Incorporated
- National Endowment for the Humanities
- John D. and Lee Ong
- Homer and Joan Rosenberg
- Maurice and Lois Schwartz
- Angeline and Orpheus J. Soprano

\$50,000-\$99,999

- AMSTED Industries Foundation
- Sidney Bates
- Edith Edward
- Bank One
- Tom and Linda Heagy
- Robert and Janet Helman
- Annette Klein
- Ira and Janina Marks
- Luther I. Replogle Foundation
- St. Lucas Charitable Foundation
- John M. Sevick

\$25,000-\$49,999

- Mrs. Marilyn B. Alsdorf
- The Coleman Foundation, Inc.
- Ernest L. Folk
- Isak and Nancy Gerson
- Richard and Mary L. Gray
- Kelly and Diana Grodzins
- Albert and Cissy Haas
- The John Nueven Company
- Wylie and May Louise Jones
- KPMG LLP
- MidCon Management Corporation
- The Northern Trust Company
- The William J. O. Roberts Family
- Norman and Alice Rubash
- Karen S. Rubinson

\$10,000-\$24,999

- Robert Z. and Deborah Aliber
- Edward and Joan Anders
- Alan R. Brodie
- Robert and Peggy Grant
- Carol Green
- Ragnhild Hickey
- A. T. Kearney, Inc.
- Barbara Morris
- Muriel Kallis Newman
- Philip Morris Companies Inc.
- Crennan and David Ray
- Philip and Barbara Reilhaus
- Greta Broadwood and Raymond D. Trodel
- Gerald L. Vincent

\$5,000-\$9,999

- Geraldine Adams
- Amoco Foundation
- Ronald B. and Marjorie
- Barbara L. De
- James and Louise S.
- Caroline and Tom T.
- IBM
- William J. O. Roberts
- ...

DEVELOPMENT

***Overleaf. Plaque commemorating successful completion of the Legacy Campaign.
Photograph by Bruce Powell***

DEVELOPMENT

Tim Cashion

Overview

Fiscal 1999 saw the Oriental Institute reach new highs in funds raised for both projects and membership revenues. Private non-federal gifts and grants totaled \$3,742,118, a 29% increase over the previous year. Membership revenues of \$147,767 represented a 15% gain over fiscal 1998. On behalf of the faculty and staff, I would like to thank our generous members and donors for their continued support of the Institute. A complete honor roll of members and donors follows this report.

Legacy Campaign

The completion of the campaign for facilities improvements — the most ambitious fund-raising effort in the Institute's history — was celebrated on 22 May 1999 at *Egypt Unveiled*, a black-tie affair held in the Joseph and Mary Grimshaw Egyptian Gallery and the Elizabeth Morse Genius Reading Room. Former Director William M. Sumner and Deputy Director of the National Endowment for the Humanities Juan E. Mestas came to Chicago for the evening, as did Barbara Breasted Whitesides, the granddaughter of Institute founder James Henry Breasted.

The Legacy Campaign, in its last year, benefited from significant gifts from Mrs. Elizabeth Baum, Robert and Linda Braidwood, Mrs. Joseph N. Grimshaw, and Crennan and David Ray among our individual supporters, and new gifts from A. T. Kearney, Ernst & Young LLP, The John Nuveen Company, and KPMG LLP from the corporate community.

The campaign booked over \$10.4 million for facilities improvements. The Institute thanks the many donors who supported the campaign and is especially grateful for the efforts of the Legacy Campaign Executive Committee, chaired by Jill Carlotta Maher, O. J. Sopranos, and Raymond D. Tindel.

Year-End Appeal

The highlight of the annual appeal, which raised over \$162,299.09 for Institute projects other than the building campaign, was the Morse Genius Challenge Grant. The challenge, set by the Elizabeth Morse and Elizabeth Morse Genius Charitable Trusts, presented the Institute with an opportunity to both modernize and restore the Reading Room. As a result of support from our members, as well as a significant effort from alumni of the Department of Near Eastern Languages and Civilizations, the Institute successfully reached the challenge goal. In late 1999, new task wiring and internet connections will be installed at each study table. In spring 2000, light fixtures replicating those originally installed will be mounted, recapturing the beauty of the 1930s-vintage room.

DEVELOPMENT

Visiting Committee

In 1998/99, the Visiting Committee to the Oriental Institute welcomed a new chair, B. F. Goodrich Chairman Emeritus John D. Ong, and new members Mrs. Deborah Aliber, Howard Haas, and Roger Nelson. Debbie is a resident of Hyde Park and a long-serving docent at the Institute. Mr. Haas, after a successful career in business, now teaches at the University of Chicago's Graduate School of Business. Mr. Nelson is the Deputy Chairman of Ernst & Young LLP. We thank all of them for joining the Committee, as well as our returning members for their loyal advocacy on behalf of the Institute.

The Visiting Committee met twice this past year, on 17 September 1998 at the Institute and on 11 March 1999 at the University Club. In September, Museum Director Karen L. Wilson briefed the Committee on the design of the Egyptian Gallery, while in March Professor McGuire Gibson updated members on archaeology in Yemen, particularly recent Institute work in the area.

In a small private ceremony on 6 January 1999, Hugo F. Sonnenschein, President of the University of Chicago, presented the James Henry Breasted Medallion to Elizabeth B. (Mrs. Theodore D.) Ticken. The Breasted Medallion is the highest honor bestowed by the Oriental Institute. Mrs. Ticken is a charter member of the Visiting Committee and has been the Institute's loyal friend and volunteer for more than four decades.

Breasted Society

The James Henry Breasted Society, our highest level of membership and a vital source of unrestricted support for the Institute's most pressing needs, enjoyed the finest year in its short history. Fiscal year 1999 Breasted Society revenues totaled \$59,309, a 19% increase over the previous year. Breasted Society funds supported, among other projects, the Research Archives, the Conservation Laboratory, faculty travel, and computer upgrades. The Breasted Society met on 17 September 1998 to dine with Barbara Mertz, a University of Chicago alumna and author, as Elizabeth Peters, of the Amelia Peabody mystery series. Many members also attended Egypt Unveiled on 22 May 1999.

Membership

There were 1,422 Basic and Associate Membership gifts in fiscal 1999, totaling \$88,548.12. Compared to the previous year, these figures represent a 14% increase in numbers of members and a 16% increase in revenues. This represents the third consecutive year that the Institute's membership has grown, despite the renovation to our galleries. Membership programming in 1998/99 included:

12 August 1998: "The City of the Hawk: Recent Excavations at Hierakonpolis," a summer Members Lecture by Renee Friedman, Director, Hierakonpolis Expedition.

16 September 1998: "Jewels of the Nile and Beyond," an Associates Luncheon (held at the Fortnightly of Chicago) featuring Barbara Natoli Witt, a renowned maker of custom jewelry.

17 September 1998: "The Ape in the Balance," a book signing and lecture by University of Chicago alumna Barbara Mertz, author, as Elizabeth Peters, of the Amelia Peabody mystery series.

21 October 1998: "A Celebration of Professor Emeritus Hans Gustav Güterbock," a Members Lecture in honor of Professor Güterbock's 90th birthday, featuring remarks by Professor Harry A. Hoffner, Professor Piotr Michalowski of the University of Michigan, Professor Hans Nissen of the Free University of Berlin, and Professor Emeritus Erica Reiner. Professor Güterbock was presented with the title page of a volume of conference papers to be published in his honor, an issue of the *Journal of Cuneiform Studies* dedicated to him, and an honorary doctorate, awarded earlier in the year by the Free University of Berlin. Professor Reiner, a friend and colleague for over forty years, spoke of Professor Güterbock's mammoth contribution to ancient Near Eastern scholarship.

6 January 1999: "Vani, a Religious Center of the First Millennium B.C. in Colchis, the Land of the Golden Fleece," a Members Lecture by Professor Otar Lordkipanidze, Director of the Institute of Archaeology, Georgian Academy of Science. Co-sponsored by the Archaeological Institute of America.

24 February 1999: "Archaeology and History in the Ancient Territory of Nikopolis," a Members Lecture and the Inaugural Oscar Broneer Lecture by James M. Wiseman of Boston University and President of the Archaeological Institute of America. Co-sponsored by the Archaeological Institute of America.

17 March 1999: "Between the Tigris-Euphrates Basin and the Mediterranean Sea," a Members Lecture by Professor K. Aslihan Yener.

7 April 1999: "From the Land of Sheba: Twenty Years of Research in Yemen," a Members Lecture by Professor McGuire Gibson. Co-sponsored by the Archaeological Institute of America.

21 April 1999: "Rolling Stones: Economy, Society, and Culture in the Sixth Century Carbonized Petra Papyri," a Members Lecture by Assistant Professor Traianos Gagos of the University of Michigan.

23 May 1999 and 26 May 1999: Free previews for members only of the new Joseph and Mary Grimshaw Egyptian Gallery.

27 May 1999: "Institute Unveiled," a behind-the-scenes tour of new object and archival storage areas.

Travel Program

The Oriental Institute Travel Program offered two overseas departures in 1998/99. *Gods, Saints, and Kings: Discovering Central Anatolian Turkey* was led by Professor Emeritus Richard L. Chambers in September 1998. Thirty-two members and friends joined Dick for touring that ranged from cosmopolitan Istanbul to Associate Professor K. Aslihan Yener's dig at Tell Kurdu in the southern province of Hatay. In January and February, Museum Archivist John A. Larson and Director of Development Tim Cashion led a private tour of Egypt for the Women's Board of the University of Chicago. The twenty-five travelers on the tour ventured from Alexandria to Abu Simbel, including an elegant dinner at Chicago House.

DEVELOPMENT**Organization**

The Office of Membership and Development passed through a period of transition in 1998/99. Cynthia Echols, Assistant Director of the Oriental Institute for Membership and Development since spring 1993, moved to a new post as Associate Director of Foundation Relations for the University of Chicago in September. Cynthia's steady hand guided the Institute through the daunting challenge of raising funds for the now-completed building, and she leaves with our best wishes.

Tim Cashion, who had been Membership Coordinator since fall 1995, was named Director of Development in November. Emily Napolitano, who had worked in the Museum Education Office since spring 1997, joined the Development Office as a part-time Development Assistant in August, and was promoted to Membership Coordinator, a full-time position, in December.

VISITING COMMITTEE TO THE ORIENTAL INSTITUTE

John D. Ong, Chair

Deborah Aliber	Ira G. Marks
Mrs. James W. Alsdorf	Janina Marks
Alan R. Brodie	Phillip L. Miller
Jean McGrew Brown	Roger R. Nelson
Anthony T. Dean	Muriel Kallis Newman
Lawrie C. Dean	Rita T. Picken
Emily Huggins Fine	Crennan M. Ray
Dr. Marjorie M. Fisher	Patrick Regnery
Mrs. James Foorman	William J. O. Roberts
Elizabeth R. Gebhard	Barbara W. Rollhaus
Paul E. Goldstein	Alice E. Rubash
Margaret H. Grant	Norman J. Rubash
Mrs. Richard Gray	Robert G. Schloerb
Mrs. Joseph N. Grimshaw	Lois M. Schwartz
Diana L. Grodzins	Maurice D. Schwartz†
Albert F. Haas*	Rev. John M. Sevick
Howard G. Haas	Mary G. Shea
Thomas C. Heagy	Jeffrey R. Short, Jr.
Janet W. Helman	O. J. Sopranos
Henrietta M. Herbolsheimer, M.D.†	Mrs. Gustavus F. Swift*
Donald H. J. Hermann	Arnold L. Tanis, M.D.
Doris B. Holleb	Mrs. Theodore D. Ticken
Marshall M. Holleb	Gerald L. Vincent
Daniel A. Lindley, Jr.	Marjorie K. Webster
Jill Carlotta Maher	Sharukin Yelda, M.D.

* Denotes life member

LEGACY CAMPAIGN EXECUTIVE COMMITTEE

Co-Chairs

Jill Carlotta Maher O. J. Sopranos Raymond D. Tindel

Jean McGrew Brown	Marshall M. Holleb
James Foorman	George M. Joseph
Paul E. Goldstein	Crennan M. Ray
Thomas C. Heagy	Robert G. Schloerb
Janet W. Helman	

HONOR ROLL OF MEMBERS AND DONORS

1998/99

We are pleased to recognize the friends of the Oriental Institute who have given so generously during the period from 1 July 1998 through 30 June 1999. We are most grateful for your support.

The Membership Honor Roll is arranged in alphabetical order within each membership level and reflects active memberships as of 30 June 1999. The Donor Honor Roll, also alphabetical, is divided into total gift levels for fiscal year 1998/99; it includes non-membership gifts only. Gifts received after 30 June 1999 will appear in next year's *Annual Report*. We have made every effort to verify gift levels and donor names. Please contact the Membership and Development Office if you wish to make changes in your honor roll listing.

MEMBERSHIP HONOR ROLL

James Henry Breasted Society

The James Henry Breasted Society includes Oriental Institute members who annually contribute \$1,000 or more (Patron) and \$2,500 or more (Director's Circle) to provide a direct, renewable source of unrestricted funds for Oriental Institute projects and for matching money to private and federal grants. We thank each of our Breasted Society members for their ongoing generosity.

Director's Circle

Mr. and Mrs. Jeffrey Anderson, Cincinnati, Ohio
 Anthony T. and Lawrie C. Dean, Long Grove, Illinois
 Mr. and Mrs. Richard Gray, Chicago, Illinois
 Mr. and Mrs. Howard Haas, Glencoe, Illinois
 Thomas and Linda Heagy, Chicago, Illinois
 Mr. and Mrs. Robert A. Helman, Chicago, Illinois
 Mr. and Mrs. Edward Hirsch Levi, Chicago, Illinois
 Ira and Janina Marks, Chicago, Illinois
 Mrs. Barbara Mertz, Frederick, Maryland
 Mr. and Mrs. Patrick Regnery, Burr Ridge, Illinois
 Mr. and Mrs. Robert G. Schloerb, Chicago, Illinois
 Mr. and Mrs. O. J. Sopranos, Winnetka, Illinois
 Mrs. Theodore D. Tieken, Chicago, Illinois
 Mrs. Roderick Webster, Winnetka, Illinois
 Ms. Flora Yelda, Chicago, Illinois
 Mrs. Jeanette Yelda, Chicago, Illinois
 Dr. and Mrs. Sharukin Yelda, Chicago, Illinois

HONOR ROLL OF MEMBERS AND DONORS**Patron**

Professor and Mrs. Robert Z. Aliber, Chicago, Illinois
 Mr. and Mrs. Howard Arvey, Santa Barbara, California
 Mr. and Mrs. Ronald R. Baade, Winnetka, Illinois
 William and Janet Backs, Evanston, Illinois
 Mr. and Mrs. Cameron Brown, Lake Forest, Illinois
 Mr. Bruce E. Clinton, Regents Park of Hyde Park, Chicago, Illinois
 Mr. and Mrs. Walter Clissold, Chapel Hill, North Carolina
 Ms. Marion Cowan, Evanston, Illinois
 Dr. Sarmed G. Elias, Chicago, Illinois
 Mrs. Emily Huggins Fine, San Francisco, California
 Dr. Marjorie M. Fisher, Bloomfield Hills, Michigan
 Leila M. Foster, J.D., Ph.D., Evanston, Illinois
 Mr. and Mrs. John W. Fritz II, Kenilworth, Illinois
 Mr. Matthew W. Dickie and Ms. Elizabeth R. Gebhard, Perthshire, United Kingdom
 Paul and Iris Goldstein, Chicago, Illinois
 Mr. and Mrs. Robert M. Grant, Chicago, Illinois
 Mrs. Joseph N. Grimshaw, Wilmette, Illinois
 Mr. and Mrs. I. A. Grodzins, Chicago, Illinois
 Mr. and Mrs. Dietrich M. Gross, Wilmette, Illinois
 Dr. Benjamin Gruber and Dr. Petra Maria Blix, Chicago, Illinois
 Mr. Ernest A. Grunsfeld III, Highland Park, Illinois
 Mr. and Mrs. Albert F. Haas, Chicago, Illinois
 Mr. and Mrs. Albert M. Hayes, Lake Forest, Illinois
 Dr. and Mrs. Arthur L. Herbst, Chicago, Illinois
 Dr. and Mrs. David C. Hess, Downers Grove, Illinois
 Mr. and Mrs. Marshall M. Holleb, Chicago, Illinois
 Wayne J. Holman III, Glen Ellyn, Illinois
 Mr. and Mrs. Roger David Isaacs, Glencoe, Illinois
 Dr. and Mrs. Raja Khuri, Evanston, Illinois
 Mr. Richard Kron, Williams Bay, Wisconsin
 Mr. and Mrs. David W. Maher, Chicago, Illinois
 Dr. William Brice McDonald, Chicago, Illinois
 Ms. Muriel Kallis Newman, Chicago, Illinois
 Mr. and Mrs. Robert F. Picken, Chicago, Illinois
 Mr. and Mrs. David K. Ray, Kansas City, Missouri
 Dr. Miriam Reitz Baer, Chicago, Illinois
 Mr. and Mrs. John F. Richards, Wilmette, Illinois
 Mr. and Mrs. Philip E. Rollhaus, Jr., Chicago, Illinois
 Mr. and Mrs. John W. Rowe, Chicago, Illinois
 Mrs. Helen J. Schwarten, Evanston, Illinois
 Mrs. Maurice Schwartz, Los Angeles, California
 Rev. John M. Sevick, Chicago, Illinois
 Mr. and Mrs. Charles M. Shea, Wilmette, Illinois
 Mr. and Mrs. Jeffrey R. Short, Jr., Winnetka, Illinois
 The Honorable George P. Shultz, Stanford, California
 Mr. John Howell Smith, New York, New York
 Mrs. Patricia Study, Chicago, Illinois
 Ms. Roxie Walker, Lignieres, Switzerland
 Brigitte Warning Watkins, Ph.D., Chicago, Illinois

Sponsoring Members (\$500–\$999)

Miss Janice V. Bacchi, Encinitas, California
 Mr. William and Mrs. Florence Boone, Glencoe, Illinois
 Ms. Margaret C. Brandt, Eminence, Kentucky
 Ms. Elizabeth L. Cheney, Washington, District of Columbia
 Richard and Sally Cook, Richmond, Virginia
 Ms. Karen Dean, Princeton, New Jersey
 Mrs. Bettie Dwinell, Chicago, Illinois
 Mr. C. K. Dykema, Chicago, Illinois
 Mrs. Ann B. Fallon, Tucson, Arizona
 Donald H. J. Hermann, Chicago, Illinois
 Mr. Raad Hermes, Chicago, Illinois
 Mr. Jim Hill, Chicago, Illinois
 Mr. and Mrs. George Joseph, Portland, Oregon
 Mr. Martin Koslin, Houston, Texas
 Mr. and Mrs. Barry L. MacLean, Mettawa, Illinois
 Mr. and Mrs. Bernard Meltzer, Chicago, Illinois
 Mr. and Mrs. Richard M. Morrow, Glenview, Illinois
 Dr. Satoshi Nagasawa, Mie Prefecture, Japan
 David and Karen Paldan, Scottsdale, Arizona
 Gerhard and N. Linn Reusswig, Dallas, Texas
 Mr. Timothy Thorne, Mount Prospect, Illinois
 Ms. Jane Wagner, East Lansing, Michigan
 Rose and Robert Wagner, Chicago, Illinois
 Ms. Margaret Wrigley, Oakland, California

Contributing Members (\$250–\$499)

Thomas G. Akers, Ph.D. and Dr. Ann B. Akers, New Orleans, Louisiana
 Mrs. Mary and Mr. Stanley Allan, Chicago, Illinois
 Mr. E. M. Bakwin, Chicago, Illinois
 Mr. Sidney J. Blair and Ms. Lamoyne C. Blair, Oak Park, Illinois
 Robert and Sharon Bright, Fayetteville, Arkansas
 Mr. Charles N. Callahan and Ms. Naila Britain, Chicago, Illinois
 Mr. Bruce P. Burbage, Springfield, Virginia
 Ms. Elizabeth F. Carter, Los Angeles, California
 Mr. Courtney B. Conte, Santa Monica, California
 Mr. and Mrs. Jeff David, New York, New York
 Mr. Paul Ehrenfest, Gulfport, Mississippi
 Mr. and Mrs. Marion Gajek, Chicago, Illinois
 Dr. Gary S. Garofalo, Palos Hills, Illinois
 Mrs. Willard Gidwitz, Highland Park, Illinois
 Ms. Louise Grunwald, New York, New York
 Mr. and Mrs. Norman Hessler, Mount Prospect, Illinois
 Mr. and Mrs. Reinhardt H. Jahn, Riverside, Illinois
 Mrs. Marjorie H. Buchanan Kiewit, Chestnut Hill, Massachusetts
 Mr. Jack A. Koefoot, Evanston, Illinois
 Dr. Elisabeth Lassers, Chicago, Illinois
 Dr. Mark Lehner, Milton, Massachusetts
 Mr. Marvin Leibowitz and Ms. Isabel Garcia, North Miami, Florida
 Mr. Paul S. Linsay and Ms. Roni A. Lipton, Newton, Massachusetts

HONOR ROLL OF MEMBERS AND DONORS**Contributing Members (\$250 – \$499) (cont.)**

Mrs. Glen A. Lloyd, Libertyville, Illinois
 Mr. and Mrs. P. E. MacAllister, Indianapolis, Indiana
 Paul and Anna Marks, Chicago, Illinois
 Mr. Dave Miner, San Francisco, California
 Mr. Grant Minervini, Welland SA, Australia
 Mr. and Mrs. Jeffrey E. Miripol, Hockessin, Delaware
 Anthony and Karole Mourek, Riverside, Illinois
 Mr. Charles Nelson, Seattle, Washington
 The Honorable and Mrs. Richard Posner, Chicago, Illinois
 Mr. George H. Railsback, Bagni Di Lucca, Italy
 Mr. and Mrs. Thad D. Rasche, Oak Park, Illinois
 Francesca Rochberg, Morena Valley, California
 Mrs. Ludwig Rosenberger, Chicago, Illinois
 Dr. Henry D. Slosser, Altadena, California
 Mr. Allen R. Smart, Chicago, Illinois
 Dr. and Mrs. Clyde Curry Smith, River Falls, Wisconsin
 Toni S. Smith, Chicago, Illinois
 Dr. Arnold and Mrs. Maxine Tanis, Fernandina Beach, Florida
 Ms. Susanne Weakley, Houston, Texas
 Evelyn and Karl Zerfoss, Elmhurst, Illinois

Supporting Members (\$100–\$249)

Ms. Judith Ackerman, Chicago, Illinois
 Dr. Donald H. Amidei, Park Ridge, Illinois
 Mrs. Joan and Mr. Edward Anders, Chicago, Illinois
 Ms. Corene Anderson, Evanston, Illinois
 Dr. Thomas Andrews, Hinsdale, Illinois
 Mr. Steven Apple, Lancaster, New York
 Dr. and Mrs. Robert Arensman, Chicago, Illinois
 Dr. Claresa Armstrong, Chicago, Illinois
 James and Beverly Armstrong, Watertown, Massachusetts
 Dr. and Mrs. Barry Arnason, Chicago, Illinois
 Mr. Willis Ashley, Scottsdale, Arizona
 Mr. Anthony J. Barrett and Ms. Marguerite Kelly, Hingham, Massachusetts
 Mrs. Bernadine Basile, Chicago Heights, Illinois
 Mr. and Mrs. Roger S. Baskes, Chicago, Illinois
 Mr. Frederick Bates and Dr. Ellen Benjamin, Chicago, Illinois
 Mrs. Elizabeth Baum, Chicago, Illinois
 Mr. and Mrs. John H. and Gail Bauman, Crete, Illinois
 Mrs. Guity Nashat Becker, Chicago, Illinois
 Ms. Jane E. Belcher, Chicago, Illinois
 Dr. Barbara Bell, Cambridge, Massachusetts
 Richard and Sally Benjamin, North Augusta, South Carolina
 Dr. Vallo Benjamin, New York, New York
 Mr. Ethan E. Bensinger, Deerfield, Illinois
 Mrs. Edwin A. Bergman, Chicago, Illinois
 Carla and Steve Berry, Chicago, Illinois
 Mr. and Mrs. Edward McCormick Blair, Lake Bluff, Illinois
 Mr. Edward C. Blau, Alexandria, Virginia

Supporting Members (\$100 – \$249) (cont.)

Glenn F. Boas, D.D.S, Chicago, Illinois
 Mr. Garry Bohm, Columbus, Indiana
 Mr. Malcolm K. Brachman, Dallas, Texas
 Mr. O. John Brahos, Wilmette, Illinois
 Raymond D. Tindel and Gretel Braidwood, Chicago, Illinois
 Nancy H. and James A. Brandt, Chicago, Illinois
 Ms. Catherine Novotny Brehm, Chicago, Illinois
 Mr. Alan R. Brodie, Chicago, Illinois
 Mr. Jonathan Brookner, Fairfield, Connecticut
 Mr. John Bross, Jr., Chicago, Illinois
 Mr. John Daniel Burton, Evanston, Illinois
 Ms. Ellen B. Cain, Dallas, Texas
 Mr. Joseph Daniel Cain, Chicago, Illinois
 Allan C. Campbell, M.D., Peoria, Illinois
 Dr. Hubert Catchpole, Chicago, Illinois
 Dr. Allan G. Charles, Chicago, Illinois
 Dr. Mary Chuman and Dr. Charles Chuman, Chesterton, Indiana
 Mr. and Mrs. E. Eric Clark, Sierra Madre, California
 Mr. Robert J. Clinkert, Aurora, Illinois
 Lydia G. Cochrane, Chicago, Illinois
 Mrs. Zdzislawa Coleman, Chicago, Illinois
 Mr. George Comminos and Ms. Linda Comminos, Chicago, Illinois
 Dorothy and David Crabb, Chicago, Illinois
 Mr. and Mrs. Albert V. Crewe, Dune Acres, Indiana
 Mr. and Mrs. Joseph Cropsey, Chicago, Illinois
 Dr. Eugene D. Cruz-Uribe and Dr. Kathryn Cruz-Uribe, Flagstaff, Arizona
 The Honorable Barbara Currie and Mr. David Currie, Chicago, Illinois
 Charles and Irene Custer, Chicago, Illinois
 Mr. Leo Darwit and Mr. Reid Selseth, Chicago, Illinois
 Ms. Alyce De Costa, Chicago, Illinois
 Mr. Walter E. De Lise, Indian Head Park, Illinois
 Mr. David Delakas, Chicago, Illinois
 Ms. Mary Dimperio, Washington, District of Columbia
 J. McGregor Dodds and Christine Dodds, Grosse Pointe Farms, Michigan
 Dr. and Mrs. Erl Dordal, Chicago, Illinois
 Mr. Justin E. Doyle and Ms. Deborah S. Doyle, Washington, District of Columbia
 Ms. Andrea M. Dudek, Orland Park, Illinois
 Pedro and Catherine Dueñas, Chicago, Illinois
 Dr. Patty L. Dunkel, Chicago, Illinois
 Mr. Robert Dyson, Gladwyne, Pennsylvania
 Mr. C. David Eeles, Columbus, Ohio
 Mr. Lawrence R. Eicher, Falls Church, Virginia
 Dr. and Mrs. Richard H. Evans, Chicago, Illinois
 Mrs. Walter D. Fackler, Chicago, Illinois
 Eugene and Sallyann Fama, Chicago, Illinois
 Ms. Linda Gail Feinstone, New York, New York
 Mr. Charles J. Fisher, Sioux City, Iowa
 Mrs. Margaret and Mr. James Foorman, Chicago, Illinois
 Mr. Richard R. Ford, Wabash, Indiana

HONOR ROLL OF MEMBERS AND DONORS**Supporting Members (\$100 – \$249) (cont.)**

Mrs. Eleanor B. Frew, Flossmoor, Illinois
 Mr. and Mrs. Thomas F. Frey, Chicago, Illinois
 Mr. and Mrs. Charles Barry Friedman, Chicago, Illinois
 Dr. and Mrs. Salman Gailani, Dyer, Indiana
 Mr. Gregory Gajda, Mt. Prospect, Illinois
 Mr. and Mrs. Michael T. Gallagher, Highland Park, Illinois
 Ms. Hildegard H. Geiger, Lake Villa, Illinois
 Mr. and Mrs. Isak V. Gerson, Chicago, Illinois
 Mr. Thomas Gillespie, Chicago, Illinois
 Mr. Lyle Gillman, Bloomingdale, Illinois
 Mr. and Mrs. Robert Dunn Glick, Chicago, Illinois
 Mr. Thomas Glonek, Chicago, Illinois
 Mr. Raymond Goehring, Lansing, Michigan
 Mr. and Mrs. William H. Gofen, Chicago, Illinois
 Mr. and Mrs. R. James Gormley, Evanston, Illinois
 Mr. and Mrs. Frederick J. Graboske, Rockville, Maryland
 Mr. and Mrs. Kenneth Granath, Lynwood, Illinois
 Mr. and Mrs. David Gratner, Sulpher Springs, Indiana
 Ms. Carol Green, Truro, Massachusetts
 Mr. Donald M. Green and Dr. Joni Grant Green, Coral Gables, Florida
 Dr. and Mrs. Nathaniel D. Greenberg, Highland Park, Illinois
 Lewis and Misty Gruber, Chicago, Illinois
 Miss Helen Ann Hagedorn, Downers Grove, Illinois
 Mr. and Mrs. Richard C. Haines, Dunwoody, Georgia
 Ellen R. Hall, Delta, Colorado
 Mr. Howard E. Hallengren, New York, New York
 Mr. Charles Scott Hamel, Chapin, South Carolina
 Mr. M. Hill and Mrs. Cheryl Hammock, Chicago, Illinois
 Dr. Lowell Kent Handy, Evanston, Illinois
 Ms. Rachel R. Hanna, Chicago, Illinois
 Commissioner and Mrs. Carl R. Hansen, Mount Prospect, Illinois
 Mr. and Mrs. William Harms, Alsip, Illinois
 Mr. Thomas Harper, Sherman Oaks, California
 Mr. and Mrs. Chauncy D. Harris, Chicago, Illinois
 Dr. Cynthia O. Harris and Mr. Leo O. Harris, Albuquerque, New Mexico
 Ms. Susan R. Harris, Ann Arbor, Michigan
 Thomas E. Hemminger, New Lenox, Illinois
 Mr. and Mrs. John A. Herschkorn, Jr., San Jose, California
 Mr. and Mrs. Roger H. Hildebrand, Chicago, Illinois
 Mr. and Mrs. David C. Hilliard, Chicago, Illinois
 Mrs. Harold H. Hines, Jr., Winnetka, Illinois
 Mr. and Mrs. George D. Hirsh, Chicago, Illinois
 Mr. William A. Hoffman, Chicago, Illinois
 Ms. Debbie Holm, Chicago, Illinois
 Mr. Rodney J. Holzkamp, Chicago, Illinois
 Mr. and Mrs. Lawrence Howe, Winnetka, Illinois
 Mr. Joe Hubbard and Ms. Linda Hubbard, Schaumburg, Illinois
 Ms. Linda Huddleston, Carrollston, Missouri
 Bill Hudson and Wade Adkisson, New York, New York

Supporting Members (\$100 – \$249) (cont.)

The Doctors Kamal and Lucy Ibrahim, Oak Brook, Illinois
 Mrs. Edwin N. Irons, Erskine, Minnesota
 Mr. and Mrs. George T. Jacobi, Milwaukee, Wisconsin
 Mrs. J. A. Jacobs, St. Louis, Missouri
 Ms. Lise Jacobson, Evanston, Illinois
 Mr. Thomas Jedele and Dr. Nancy J. Skon Jedele, Laurel, Maryland
 Mr. Charles E. Jones, Chicago, Illinois
 Ms. Cleo Kiergaard, McFarland, Wisconsin
 Professor Anne Draffkorn Kilmer, Walnut Creek, California
 Mr. and Mrs. Hong Jik Kim, Northbrook, Illinois
 Mr. John and Mrs. Laura Kingsbury, Manitowish Waters, Wisconsin
 Mr. and Mrs. H. David Kirby, Owings Mills, Maryland
 Charles and Rose Tracy Kirschner, Belvidere, Illinois
 Ms. Evelyn Kitagawa, Chicago, Illinois
 Joseph S. Klemek, M.D., Orange, California
 Mr. and Mrs. William J. Knight, South Bend, Indiana
 Mr. Michael E. Koen, Chicago, Illinois
 Roger and Karen Konwal, Elmhurst, Illinois
 Ms. Hana Kotek, Furqay Varina, North Carolina
 Mr. and Mrs. Louis E. Kovacs, Chicago, Illinois
 Mr. Bernard L. Krawczyk, Chicago, Illinois
 Ms. Erika S. Kuiper, Ottawa, Illinois
 Mr. and Mrs. Alvin W. Ladd, Rancho Palos Verdes, California
 Dr. Susanne E. Larsh, Chicago, Illinois
 Mr. and Mrs. William J. Lawlor III, Kenilworth, Illinois
 Dr. and Mrs. Leonard Henry Lesko, Barrington, Rhode Island
 Mr. and Mrs. Theodore W. Liese, Prescott, Arizona
 Mr. Robert A. Lindquist, Jr., Des Plaines, Illinois
 Kathleen and Michael Lisle, Chicgao, Illinois
 Mr. and Mrs. Richard Loewenthal, Winnetka, Illinois
 Mr. Lou L. Long, Bellevue, Washington
 Mrs. Nina A. Longley, Park Forest, Illinois
 Professor and Mrs. James Lorie, Chicago, Illinois
 Mr. Philip R. Luhmann and Mrs. Dianne C. Luhmann, Chicago, Illinois
 Ms. Leslie W. MacDonald, Chicago, Illinois
 Mr. and Mrs. Laurance L. MacKallor, San Carlos, California
 Mr. Daniel R. Malecki, Kensington, California
 Ms. Maria Danae Mandis, Chicago, Illinois
 Mr. and Mrs. Robert J. Marshall, Chicago, Illinois
 Mr. Robert Martin, Glenview, Illinois
 Ms. Masako I. Matsumoto, Chicago, Illinois
 Dr. Beatrice McCown Mattison, Washington, District of Columbia
 Ms. Marilyn McCaman, La Verne, California
 Mr. W. Sloan McCrea, Miami, Florida
 Ms. Patricia McLaughlin, Hinsdale, Illinois
 Mr. Stephen Mican, Chicago, Illinois
 Ronald Michael, M.D., Bourbonnais, Illinois
 Ms. Melissa Brisley Mickey, Chicago, Illinois
 Mr. Richard A. Miller, Oak Lawn, Illinois

HONOR ROLL OF MEMBERS AND DONORS**Supporting Members (\$100 - \$249) (cont.)**

Dr. William K. Miller, Duluth, Minnesota
 The Honorable Martha Mills, Chicago, Illinois
 Mr. Robert Ralph Moeller and Ms. Lois Patricia Moeller, Evanston, Illinois
 Mr. Er-Rafia Mohammed and Ms. Yamashita Suzuko, Kanagawa, Japan
 Ms. Maria A. Morelli, Sugar Grove, Illinois
 Mr. and Mrs. William L. Morrison, Chicago, Illinois
 Dr. Andrew Meulenberg and Mrs. Paulette A. Muelenberg, Dorwood, Maryland
 Mr. Robert Mueller, Chicago, Illinois
 Ms. Holly J. Mulvey, Evanston, Illinois
 George E. Murphy, M.D., St. Louis, Missouri
 Dr. Rosanne S. Naunheim and Dr. Keith Shelby Naunheim, St. Louis, Missouri
 Ms. Mary B. Naunton, Chicago, Illinois
 Mr. Walter A. Netsch, Jr. and Dawn Clark Netsch, Chicago, Illinois
 Mr. Robert W. Newman, Chicago, Illinois
 Mr. John P. Nielsen, Lombard, Illinois
 Mr. Dale George Niewoehner, Rugby, North Dakota
 Mr. and Mrs. Charles D. O'Connell, Chicago, Illinois
 Ms. Virginia O'Neill, Chicago, Illinois
 Mr. and Mrs. William R. Oostenbrug, Lakeside, Michigan
 Mrs. Franklin B. Orwin, Chicago, Illinois
 Mr. Mark M. Osgood, Burr Ridge, Illinois
 Mrs. Dean B. Phemister, Wilmette, Illinois
 Miss Kathleen Picken, Chicago, Illinois
 Ms. Genevieve Plamondon, Chicago, Illinois
 Mrs. George A. Poole, Lake Forest, Illinois
 Mr. and Mrs. Newell Pottorf, Tulsa, Oklahoma
 Ms. Judy Prince, Chicago, Illinois
 Mr. and Mrs. Gordon Prussian, Chicago, Illinois
 Mr. and Mrs. Joseph Radov, Northfield, Illinois
 Dr. David Reese and Catherine Sease, Chicago, Illinois
 Mr. Clemens Reichel, Chicago, Illinois
 Alan and Laurie Reinstein, Highland Park, Illinois
 Dr. Dominick S. Renga, Highland Park, Illinois
 Mr. and Mrs. James T. Rhind, Glenview, Illinois
 Mr. and Mrs. George G. Rinder, Burr Ridge, Illinois
 Dr. Robert H. Beebe and Dr. Ruth Robbins, Chicago, Illinois
 Mr. William Hughes Roberts, Las Vegas, Nevada
 Mr. and Mrs. H. P. Rockwell, Olympia Fields, Illinois
 Mr. David J. Rogal, Hoffman Estates, Illinois
 Mr. Howard J. Romanek, Skokie, Illinois
 Mr. and Mrs. Philip Rootberg, Chicago, Illinois
 Mrs. Samuel R. Rosenthal, Chicago, Illinois
 Mrs. John G. Roth, Hillsboro, Oregon
 Mr. George Rumney, Bowie, Maryland
 Mr. and Mrs. F. Garland Russell, Jr., Columbia, Missouri
 Mrs. Robert G. Sachs, Chicago, Illinois
 Dr. and Mrs. Leo Sadow, Chicago, Illinois
 Mr. Bruce Sagan and Ms. Bette Cerf Hill, Chicago, Illinois
 Paul Saltzman, M.D. and Ms. Bettylu K. Saltzman, Chicago, Illinois

Supporting Members (\$100 – \$249) (cont.)

Harold and Deloris Sanders, Chicago, Illinois
 John and Peggy Sanders, Chicago, Illinois
 Mr. and Mrs. Calvin P. Sawyer, Chicago, Illinois
 Rolf and Charlotte Scherman, Greenbrae, California
 Floyd and Ina Schlossberg, Morton Grove, Illinois
 Mr. and Mrs. Frank L. Schneider, Chicago, Illinois
 Mr. Richard M. Schoen and Mr. Charles P. Gard, Schererville, Indiana
 Mr. Michael Schreiber, New York, New York
 Ms. Lillian H. Schwartz, Chicago, Illinois
 Professor Giovanni Semerano, Florence, Italy
 R. Chesla Sharp and Ruth M. Sharp, Limestone, Tennessee
 Ms. Emma Shelton, Bethesda, Maryland
 Mr. Henry Showers, Calumet City, Illinois
 Mr. Michael A. Sisinger and Ms. Judith E. Waggoner, Columbus, Ohio
 Mr. Jackson W. Smart, Jr., Winnetka, Illinois
 Ms. Patricia A. Soltys, Chicago, Illinois
 Mr. D. Paul Spencer, Metairie, Louisiana
 Mr. Stephen C. Sperry, Litchfield, Minnesota
 Dr. Jean-Paul Spire, Chicago, Illinois
 Ms. Carla Stedwell, San Francisco, California
 Mr. Maurice C. Stefani, Sacramento, California
 Mrs. Robert Steinbach, Kansas City, Missouri
 Mayer and Gloria Stern, Chicago, Illinois
 The Honorable and Mrs. Adlai E. Stevenson, III, Chicago, Illinois
 Mr. and Mrs. Stephen M. Stigler, Chicago, Illinois
 Dr. and Mrs. Francis H. Straus II, Chicago, Illinois
 Linda Stringer, Garland, Texas
 Mrs. Alec Sutherland, Chicago, Illinois
 Mr. John E. Swearingen, Chicago, Illinois
 Dr. and Mrs. C. Conover Talbot, Chicago, Illinois
 Miss Maryann M. Taranowski, Woodstock, Illinois
 Mr. Justin Tedrowe, Downers Grove, Illinois
 Ms. Emily Teeter, Chicago, Illinois
 Mr. and Mrs. Thomas E. Thomason, Cairo, Egypt
 Mr. and Mrs. Robert L. Toth, Medina, Ohio
 Mr. Gilbert D. Totten, Chicago, Illinois
 Mrs. Nancy E. Turchi, Lake Zurich, Illinois
 Mrs. Harriet N. Turk, Joliet, Illinois
 Dr. Robert Y. Turner, Philadelphia, Pennsylvania
 Mr. and Mrs. Edgar J. Uihlein, Jr., Lake Bluff, Illinois
 Dr. and Mrs. John E. Ullmann, Chicago, Illinois
 Mr. Lorenzo M. Vigano, Chicago, Illinois
 Frank and Eleanor Voysey, Wilmette, Illinois
 Mr. and Mrs. Maurice Walk, Highland Park, Illinois
 Mr. Charles S. Walker, Tempe, Arizona
 Mr. and Mrs. Christopher Warren, Detroit, Michigan
 Ms. Chilton Watrous and Mr. A. V. Pogaryan, Istanbul, Turkey
 Mr. Richard F. Watt and Ms. Sherry B. Watt, Chicago, Illinois
 Mr. and Mrs. Charles W. Wegener, Chicago, Illinois

HONOR ROLL OF MEMBERS AND DONORS**Supporting Members (\$100 - \$249) (cont.)**

Mr. John R. Weiss, Wilmette, Illinois
 Mr. Douglas J. Wells, Valparaiso, Indiana
 Mr. and Mrs. Edward F. Wentz, Chicago, Illinois
 Mr. and Mrs. John J. White III, Columbus, Ohio
 Mr. Leon Levy and Ms. Shelby White, New York, New York
 Mr. and Mrs. Thomas J. White, Oakland, California
 Dr. Willard E. White, Riverside, Illinois
 Mrs. Warner A. Wick, Chicago, Illinois
 Mr. John L. Wier and Ms. Elizabeth B. Wier, Naperville, Illinois
 Wayne and Lois Wille, Radford, Virginia
 Mr. Charles Mack Wills, Jr., Simpsonville, South Carolina
 Mrs. William A. Wilson, Burr Ridge, Illinois
 Mr. and Mrs. Robert I. Wilson, Peoria, Illinois
 Dr. Wendall W. Wilson, Chicago, Illinois
 Mrs. Jack Witkowsky, Chicago, Illinois
 Mr. and Mrs. Richard L. Wood, Barrington Hills, Illinois
 Ms. Ruth Hunt Wood, Lexington, Kentucky
 Mr. Thomas Wukitsch
 Quentin and Ruth Young, Chicago, Illinois
 Mr. and Mrs. Arnold and Agnes Zellner, Chicago, Illinois

Sustaining Members (\$50-\$99)

D. M. Abadi and Mary C. Abadi, Iowa City, Iowa
 Mr. Beau Abdenour, Shaker Heights, Ohio
 Mrs. Lester S. Abelson, Chicago, Illinois
 Ms. Stephanie Agresta, Huntington, Connecticut
 Ms. Judith Akers, Winnetka, Illinois
 Mr. and Mrs. Walter Alexander, Geneva, Illinois
 Mr. and Mrs. Joseph Alvarado, Munster, Indiana
 Mrs. Geraldine Alvarez, Clarendon Hills, Illinois
 Mrs. Jean B. Anderson, Los Alamos, New Mexico
 Mr. and Mrs. Roger W. Anderson, Naperville, Illinois
 Mrs. Julie Antelman, Chicago, Illinois
 Ms. Sharon Avery and Mr. Philip Rychel, Tulsa, Oklahoma
 Mr. Ruben J. Baer and Dr. Leah R. Baer, Skokie, Illinois
 Mr. Tommy L. Baker, Tulsa, Oklahoma
 Ms. Lynn A. Baril, Culver City, California
 Mr. Paul Barron and Ms. Mary Anton, Chicago, Illinois
 Barry Baumgardner, Dunnellon, Florida
 Ms. Carolyn Beeman, Ferndale, Michigan
 Mr. John Benson, Glenview, Illinois
 A. W. Berens, Redwood City, California
 Mr. and Mrs. Jon Peter Berge, Batavia, Illinois
 Mr. and Mrs. Keki R. Bhote, Glencoe, Illinois
 Mr. Roger J. Bialcik, Downers Grove, Illinois
 Mr. and Mrs. David L. Blumberg, Highland Park, Illinois
 Mrs. George V. Bobrinskoy, Jr., Chicago, Illinois
 Ms. Wanda Bolton, Chicago, Illinois
 Mrs. Winthrop Palmer Boswell, Hillsborough, California

Sustaining Members (\$50 – \$99) (cont.)

James T. and Louise Bradbury, Knoxville, Tennessee
 Professor and Mrs. Jerald C. Brauer, Chicago, Illinois
 Ms. Olive N. Brewster, San Antonio, Texas
 Robert and Jane Calvin, Chicago, Illinois
 Mr. Robert Cantu, Romeoville, Illinois
 Mr. and Mrs. Arthur Caraher, Chicago, Illinois
 Mr. Thomas Cassidy, Littleton, Colorado
 Mrs. Lalitha Chandrasekhar, Chicago, Illinois
 Miss Mary E. Chase, Flossmoor, Illinois
 Rory and Michele Childers, Chicago, Illinois
 Mr. and Mrs. James Chrobak, Chicago, Illinois
 Mr. Timothy P. Clougherty and Ms. Linda M. Clougherty, Rolling Hills Estate, California
 Ms. Charlotte C. Collier, Springfield, Missouri
 Mr. Omar Coloru, Lucca, Italy
 Mr. Thomas F. Cope, Denver, Colorado
 Judith and William Cottle, Winnetka, Illinois
 Mr. and Mrs. Mark Crane, Winnetka, Illinois
 Mr. Merritt J. Davoust and Lynne Rauscher-Davoust, Elmhurst, Illinois
 Dr. Luis Malpica de Lamadrid and Mrs. Maria de la Paz de Malpica, Mexico DF Mexico
 Dr. Carl E. De Vries and Carol L. De Vries, Chicago, Illinois
 Mr. and Mrs. Nirmal S. Dhesi, Santa Rosa, California
 Mr. Henry S. Dixon and Ms. Linda Giesen, Dixon, Illinois
 Dr. Eric Doret, Geneva, Switzerland
 Mr. and Mrs. Marvin W. Ehlers, Deerfield, Illinois
 Mr. Frederick Elghanayan, New York, New York
 Miriam and Alex Elson, Chicago, Illinois
 Gerald and Margaret Entman, Chicago, Illinois
 Mr. L. A. Everitt, Kent, United Kingdom
 Mr. and Mrs. W. H. Fifield, Crown Point, Indiana
 Mrs. Laura Kramer Fisher, Highland Park, Illinois
 Dr. Michael Flom, St. Louis, Missouri
 Mr. Anthony Florek, Austin, Texas
 Mr. Robert L. Friedlander, Chicago, Illinois
 Mr. Phillip K. George, Ravenna, Ohio
 Ms. Mary R. Gilkey, Evanston, Illinois
 Ms. Ann Goddard, St. Louis, Missouri
 Mr. Ogden Goelet, Jr., New York, New York
 Mr. and Mrs. Howard Goldberg, Chicago, Illinois
 Mr. Marvin J. Goldblatt and Dr. Phyllis K. Goldblatt, Evanston, Illinois
 Mrs. Arthur Gordon, Chicago, Illinois
 Dr. and Mrs. John J. Grabowski, Newbury, Ohio
 Dr. Joseph Greene and Mrs. Eileen Caves, Belmont, Massachusetts
 Ms. Katherine Griffis-Greenberg, Birmingham, Alabama
 Robert and Arnetta Hanawalt, Aurora, Colorado
 Mr. Joel L. Handelman and Sarah R. Wolff, Chicago, Illinois
 Mr. and Mrs. C. Rollins Hanlon, Kenilworth, Illinois
 Ms. Prudence O. Harper, New York, New York
 Richard and Mary Harter, Chicago, Illinois
 Mr. and Mrs. Robert Haselkorn, Chicago, Illinois

HONOR ROLL OF MEMBERS AND DONORS**Sustaining Members (\$50 – \$99) (cont.)**

Mrs. John G. Hawthorne, Chicago, Illinois
 Mr. John C. Hayman, Mokena, Illinois
 Mrs. Idrienne L. Heymann, Highland Park, Illinois
 Mr. and Mrs. Edward S. Hintzke, Winnetka, Illinois
 Mrs. David Hoffman, Evanston, Illinois
 Mr. Charles A. Holman, Sarasota, Florida
 Ms. Ruth Holmes, Bloomfield Hills, Michigan
 Mr. and Mrs. Myron Horvitz, Glencoe, Illinois
 Miss Susan D. Hoyne, Elgin, Illinois
 Mr. A. A. Imberman, Evanston, Illinois
 Mr. D. Gale Johnson, Chicago, Illinois
 Mrs. Samantha Johnson, Chicago, Illinois
 Dr. and Mrs. Richard Jones, Chicago, Illinois
 Drs. Michael and Maureen Kaplan, Lexington, Massachusetts
 Ms. Toyoko Kawase, Japan
 Walter J. and Eva S. Kelly, Chicago, Illinois
 Mr. and Mrs. Winston E. Kennedy, Chicago, Illinois
 Mr. and Mrs. John C. Kern, Chicago, Illinois
 Dr. and Mrs. D. G. Kilgore, Jr., Greenville, South Carolina
 Miss Henriette L. Klawans, Chicago, Illinois
 Mr. and Mrs. Henry H. Kohl, Media, Pennsylvania
 Neil J. Krakauer, M.D., Chicago, Illinois
 Mr. James Kulikauskas, Arlington Heights, Illinois
 Mr. John Lawrence, Ann Arbor, Michigan
 Mr. Michael J. Lutz, Chicago, Illinois
 Mr. and Mrs. James and Roberta Maish, Barrington, Illinois
 Dr. John F. Makowski, Chicago, Illinois
 Mrs. Barbara J. Malone, Summerfield, Florida
 Ms. Donna Masaveg, Garfield Heights, Ohio
 Mr. and Mrs. Tony Mathys, St. Paul, Minnesota
 Mr. Donald Matthews and Ms. Joanna Farmer, St. Louis, Missouri
 Mrs. R. E. Maynard, Chicago, Illinois
 Mr. Kevin McDonald and Ms. Judy Chan, Chicago, Illinois
 Mr. Kevin McDonald, Los Angeles, California
 Mr. Richard H. Meadow, Canton, Massachusetts
 Henry Meisels and Sarah Meisels, Wheaton, Illinois
 Mrs. Margaret S. Meyer, Chicago, Illinois
 Janet and David Midgley, Chicago, Illinois
 Michael and Ruth Millar, Cedar Falls, Iowa
 William E. and Fern A. Miller, St. Paul, Minnesota
 Professor and Mrs. Heshmat Moayyad, Chicago, Illinois
 Dr. and Mrs. D. Read Moffett, Hinsdale, Illinois
 Mr. Charles Mottier, Chicago, Illinois
 Mrs. Margaret Wilson Myers, Blue Hill, Maine
 Mrs. F. Esther Naser, Chicago, Illinois
 Dr. William F. Nelson, Martin, Tennessee
 Mrs. Marian Glennon Newell, Chicago, Illinois
 Mr. and Mrs. James Nicholson, Pickerington, Ohio
 Mr. Elias Nouh, Verdun, Quebec, Canada

Sustaining Members (\$50 – \$99) (cont.)

Ms. Marilyn Oleck, Chicago, Illinois
 Ms. Caryl Osborn, Las Vegas, Nevada
 Arthur Eric Ostergard, M.D., Lake Oswego, Oregon
 Nr. Kevin Owens, Carpentersville, Illinois
 Mr. Kenneth Petchenik, Chicago, Illinois
 Mr. John L. Peterson, Altamonte Springs, Florida
 Dr. Eugene L. Balter and Mrs. Judith R. Phillips, Chicago, Illinois
 Dr. Janet Piedilato, Staten Island, New York
 Mr. and Mrs. Don Pitzen, Chicago, Illinois
 Mr. Paul Plechavicius III, Chicago, Illinois
 Dr. and Mrs. James C. Pritchard, Geneva, Illinois
 Ms. Jane Pugh, Chicago, Illinois
 Joseph and Jo Ann Putz, Palos Heights, Illinois
 Mr. Guy Rachet, Paris, France
 Christen and Agnethe Rattenborg, Chicago, Illinois
 Mr. David E. Reese, Chicago, Illinois
 Mr. Robert L. Reich, Chicago, Illinois
 Louise Lee Reid, Clarendon Hills, Illinois
 Mr. and Mrs. Gary W. Rexford, Topeka, Kansas
 Mr. Stephen K. Ritzel, Chicago, Illinois
 Ms. Agnes Ann Roach, Gurnee, Illinois
 Dottore Romano Romoli, Florence, Italy
 Mrs. Morris M. Rossin, Chicago, Illinois
 Mr. Richard F. Roszko, Arlington Heights, Illinois
 Mrs. A. Loring Rowe, Edgartown, Massachusetts
 Mr. Dennis Rupert and Ms. Karen Johnson, Chicago, Illinois
 Ms. Janet Russell, Concord, California
 Dr. John H. Rust, Chicago, Illinois
 Mr. and Mrs. Patrick G. Ryan, Winnetka, Illinois
 Mr. and Mrs. John Sarr, Portland, Oregon
 Mr. and Mrs. David P. Schippers, Chicago, Illinois
 Dr. and Mrs. Sidney Schulman, Chicago, Illinois
 Mr. and Mrs. Robert E. Shapiro, Chicago, Illinois
 D. F. and Agnes Shortino, Chicago, Illinois
 Mr. and Mrs. Roland H. Siebens, Glen Ellyn, Illinois
 Mr. and Mrs. Annemie and George Sinka, Lombard, Illinois
 Mr. Robert K. Smither, Hinsdale, Illinois
 Mr. Michael J. Sobczyk, Addison, Illinois
 Mr. Nariman Solhkhah, Chicago, Illinois
 Dr. and Mrs. William Sosnowsky, Grosse Pointe, Michigan
 Mr. Avraham Spinka, Chicago, Illinois
 Mr. Paul Stanwick, New York, New York
 William M. Sumner and Kathleen J. Sumner, Columbus, Ohio
 Mr. and Mrs. Douglas B. Teaney, Evanston, Illinois
 Dr. and Mrs. David Terman, Wilmette, Illinois
 Ms. Denise Thomas, Pontiac, Michigan
 Mr. Barry E. Thompson and Ms. Judithe A. Thompson, Gallipolis, Ohio
 Miss Kristin Thompson, Madison, Wisconsin
 Mrs. Manley Thompson, Chicago, Illinois

HONOR ROLL OF MEMBERS AND DONORS**Sustaining Members (\$50 – \$99) (cont.)**

Mr. and Mrs. John E. Townsend, Winnetka, Illinois
 Russ and Marlene Tuttle, Chicago, Illinois
 Ms. Jeannette K. Van Dorn, Wauwatosa, Wisconsin
 Ms. Della Vanhuss, Central, South Carolina
 Torger Vedeler, St. Paul, Minnesota
 Mr. Don Wacker and Mary C. Wacker, Issaquah, Washington
 Mr. and Mrs. Charles Ward, Streamwood, Illinois
 Mr. John P. Ward, New Britain, Connecticut
 Mr. John F. Warnock, Mason City, Illinois
 Professors Richard and Patty Jo Watson, University City, Missouri
 Mr. and Mrs. Steven B. Weingartner, Brookfield, Illinois
 Mr. and Mrs. J. Marshall Wellborn, New York, New York
 Mrs. Barbara Breasted Whitesides, Newton, Massachusetts
 Mr. Frank A. Wilczek, Princeton, New Jersey
 Ms. Alexandra Helen Wilkinson, London, United Kingdom
 Ms. Jacqueline B. Winter, Evanston, Illinois
 Rabbi and Mrs. Arnold Jacob Wolf, Chicago, Illinois
 Mr. Mark R. Yim, Tokyo, Japan
 Mr. Robert R. Yohanan and Ms. Joan E. Yohanan, Kenilworth, Illinois
 Ms. Carole Y. Yoshida, Crestwood, Illinois

Annual Members (\$35–\$49)

Annabel Abraham, Oak Park, Illinois
 Mr. Daniel Accetturo, Chicago, Illinois
 Mr. Jerry J. Adamek, Chesaning, Michigan
 Mrs. Judith H. Adams, Covington, Kentucky
 Allen Adcock, Chicago, Illinois
 Ms. Yvette Adeosun, Chicago, Illinois
 Ms. Virginia Lee Adi, Portola Valley, California
 Mr. and Mrs. Paul Adlaf, Park Ridge, Illinois
 Jay and Sharon Adler, Cary, Illinois
 Mr. William Adler, Van Nuys, California
 Egidio Affuso, Fabriano, Italy
 Ms. Annika Agemans, Gent, Belgium
 Dr. Maria Ahlstrom, Chicago, Illinois
 The Honorable James and Marjorie Akins, Washington, District of Columbia
 Ms. Sonia Aladjem, Chicago, Illinois
 Ms. Ellen Alberding, Chicago, Illinois
 Mr. and Mrs. Russell Alberding, Lake Bluff, Illinois
 Mr. John R. Alden, Ann Arbor, Michigan
 Ms. Yokhana Alkass, Niles, Illinois
 Joyce Allen, Chicago, Illinois
 Dr. Michael Amaral, Bloomington, Illinois
 Mrs. Sara Anastaplo, Chicago, Illinois
 Dr. Burton Andersen, Chicago, Illinois
 Ms. Barbara N. Anderson, Riverdale, Illinois
 Mr. Thomas Andersson, Skovde, Sweden
 Mr. and Mrs. Evan and Mary Appelman, Kensington, California
 Mr. Andrew Apter and Ms. Lauren Hutchinson Derby, Chicago, Illinois

Annual Members (\$35 – \$49) (cont.)

Ms. Harriet Arbetman, Green Valley, Arizona
 Ms. Ann Arbour, Attleboro, Massachusetts
 Mr. Odun Arechaga, Chicago, Illinois
 Mr. Ernest Armstrong, Chicago, Illinois
 Ms. Ardell Arthur, Chicago, Illinois
 Mr. and Mrs. Edward H. Ashment, Manteca, California
 Mr. Michael C. Astour, Collinsville, Illinois
 Mr. and Mrs. John Asumendi, Amboy, Illinois
 Ms. Clare E. Atkinson, Tonawanda, New York
 Ms. Bettina Ault, Memphis, Tennessee
 Donna M. Avery, Ed.D., Chicago, Illinois
 Ms. Mary Bachvarova, Chicago, Illinois
 Dr. Gabor Badics, Vienna, Austria
 Mrs. Barbara Baechler, El Cajon, California
 Mr. John Bagnole, Athens, Ohio
 Mr. and Mrs. Robert A. Bailey, Paterson, New Jersey
 David and Barbara Baird, Plainfield, Illinois
 Dr. Barry Bandstra, Holland, Michigan
 Ms. Arlene R. H. Bansal, Phoenix, Arizona
 Mr. Joseph Barabe, Oak Park, Illinois
 Dr. and Mrs. Herbert R. Barghusen, Chicago, Illinois
 Mr. John P. Baril, Lincoln Park, Michigan
 Miss M. Elizabeth Barker
 Professor M. A. R. Barker, Minneapolis, Minnesota
 Ms. Kate Barnash, Chicago, Illinois
 Mr. Manuel F. Barroso and Mrs. Laia Marti, Barcelona, Spain
 Mr. and Mrs. Charles H. Barrow, Evanston, Illinois
 Ms. Judith Barrowman, Kalamazoo, Michigan
 Professor Amin Bassrei, Salvador BA, Brazil
 Ms. Cynthia Bates, Chicago, Illinois
 Ms. Margaret Bates, Sarasota, Florida
 Mr. Douglas Baum and Mrs. Lynne Wait, Homewood, Illinois
 Mr. and Mrs. Richard W. Baum, Chicago, Illinois
 Mrs. Robert Baumgarten, Palm Desert, California
 Dr. Ishoona I. Beblis, Aventura, Florida
 Ms. Carol Beckendorf, Barrington, Illinois
 Mr. William Becker, East Troy, Wisconsin
 Mr. and Mrs. Ben C. Bedford, Jr., Chattanooga, Tennessee
 Dr. Helen R. Beiser, Chicago, Illinois
 Mr. William L. Belew, Fair Oaks, California
 Ms. Jennifer Benedict, Addison, Illinois
 Ms. Dorothy Bennetch
 Ms. Catherine Bennett, Des Moines, Iowa
 Ms. Deanna Bennett, Chicago, Illinois
 Mr. William T. Bennett, Washington, District of Columbia
 Ms. Janet A. Berardo, Chicago, Illinois
 Mr. and Mrs. Hans D. Betz, Chicago, Illinois
 Mr. David and Mrs. Margaret Bevington, Jefferson, Ohio
 Mr. and Mrs. Charles E. Bidwell, Chicago, Illinois

HONOR ROLL OF MEMBERS AND DONORS**Annual Members (\$35 – \$49) (cont.)**

Mr. Zayn Bilkadi, Mahtomedi, Minnesota
 Jim and Camille Blachowicz, Evanston, Illinois
 Ms. Diane R. Blaine, Downers Grove, Illinois
 Ms. Rebecca Blair, La Mesa, California
 Mr. Jim Blake and Ms. Kelly Morgan, Evanston, Illinois
 Ms. Ann Blasingham, Athens Greece
 Mr. and Mrs. Richard Blindt, Naperville, Illinois
 Mr. Richard Ray Blocker and Mrs. Caroline Clinton-Blocker, Chicago, Illinois
 Mr. and Mrs. Bruce A. Blomstrom, San Marino, California
 Ms. Betty Blum, Chicago, Illinois
 Rev. Alison Boden, Chicago, Illinois
 Mrs. Sara J. Denning Bolle, Portland, Oregon
 Massimo Bombana, Milano, Italy
 Dr. Constance Bonbrest, Chicago, Illinois
 Mr. Steven Bono and Ms. Rosemary S. Bono, Kenilworth, Illinois
 Mrs. Abraham Bookstein, Chicago, Illinois
 Ms. Kathleen A. Boone, Fox Worth, Texas
 Ms. Suzanne Booth, Mesz, Arizona
 Mrs. Charles D. Borst, Chicago, Illinois
 Ms. Judith Bost, Dardanelle, Arkansas
 Ms. Deborah Bovee, Lehigh Acres, Florida
 Ms. Tricia Bowling, Mobile, Alabama
 Mr. Michael Bozeman, Indianapolis, Indiana
 Mr. and Mrs. Norman M. Bradburn, Chicago, Illinois
 Mr. and Mrs. John Brady, Chicago, Illinois
 Mr. and Mrs. Douglas Braidwood, Virginia Beach, Virginia
 Mr. John Bramwell Ms. Dolores Janicki, Mesa, Arizona
 Dr. and Mrs. Ethan M. Braunstein, Indianapolis, Indiana
 Mr. Paul M. Breit, Tinley Park, Illinois
 Mr. Bob Brier, Greenvale, New York
 Dawn Bronson, Palos Heights, Illinois
 Mr. and Mrs. James T. Brophy, Oak Brook, Illinois
 James F. and Susan J. Brownfield, Uniontown, Pennsylvania
 Ms. Mildred D. Broxon, Seattle, Washington
 Mr. and Mrs. William E. Brubeck, Mount Carmel, Illinois
 Jan Brud, Chicago, Illinois
 Mr. and Mrs. Lee Brunka, Barrington, Illinois
 Mr. Earl S. Bryant, Chicago, Illinois
 Mr. James B. Buchanan, Vancouver, British Columbia, Canada
 Ms. Myllicent Buchanan, Chicago, Illinois
 Mr. Glenn Bucher, Evanston, Illinois
 Mr. and Mrs. Andrew Buncis, Chicago Heights, Illinois
 Ms. Ronnie Burbank, Toronto, Ontario, Canada
 Mr. M. J. Peterson Burfield, Toronto, Ontario, Canada
 Mr. and Mrs. Edward T. Burke, United Kingdom
 Mr. Robert A. Burke, Lutherville, Maryland
 Ms. Judith Busch, Chicago, Illinois
 Ms. Jan Bush, Alexandria, Virginia
 Ms. Marie Buttery, El Cerrito, California

Annual Members (\$35 - \$49) (cont.)

Miss Janet E. M. Calkins, Chicago, Illinois
 Ms. Mary C. Calteaux, Hinsdale, Illinois
 Andrew Campbell, Chicago, Illinois
 Dr. and Mrs. Edward F. Campbell, Jr., Evanston, Illinois
 Mr. and Mrs. Stephen C. Carlson, Chicago, Illinois
 Shirley R. and William L. Carlberg, Evergreen Park, Illinois
 Ms. Toni Castel
 Mr. Robert A. Cating, Marengo, Indiana
 Ms. Elizabeth Cawelti, Chicago, Illinois
 Professor Henri Cazelles, Paris VI, France
 Mr. and Mrs. Paul R. Cekan, M.D., Chicago, Illinois
 Mr. Ronald Chalmers
 Claire Chamberlain, Houston, Texas
 Dr. J. Harley Chapman, Jr., Palatine, Illinois
 Ms. Elsa Charlston, Chicago, Illinois
 Ms. Brianne Chase, Shelburne, Vermont
 Ms. Amanda Cheau, Staten Island, New York
 Mr. Edward H. Chippus, North Olmsted, Ohio
 Ms. Catherine Chou, Hong Kong, Peoples Republic of China
 Ms. Nancy J. Christiansen, Rockford, Illinois
 Ms. Lucille Christopher, Greenville, Pennsylvania
 Mr. and Mrs. Robert Chwedyk, Algonquin, Illinois
 Professor Claudio Cioffi-Revilla, Boulder, Colorado
 Mr. Steven Cirillo, Madison, Wisconsin
 Mr. David Foster Clapp, Hixson, Tennessee
 Mr. Harris H. Clark, Tempe, Arizona
 Ms. Rosemary Clark, Elmhurst, Illinois
 Ms. Lea Cloninger, Chicago, Illinois
 Mr. Richard Coffman, Charlotte, North Carolina
 Mr. W. W. Cofield, Georgetown, Texas
 Ms. Muriel A. Cohen, Lincolnwood, Illinois
 Mr. Lawrence M. Coleman, Chicago, Illinois
 Miss Patricia J. Collette, Chicago, Illinois
 Mr. John J. Collins and Ms. Adela Yarbrow Collins, Flossmoor, Illinois
 Mr. and Mrs. Dennis Collins, Downers Grove, Illinois
 Mr. Joseph M. Conte, Chicago, Illinois
 Mr. Edward Cook, Chicago, Illinois
 Mr. and Mrs. David W. Cooper, Riverside, Illinois
 Dr. Jerrold Stephen Cooper, Baltimore, Maryland
 Dr. Lewis W. Coppel, Chillicothe, Ohio
 Professor Lorelei H. Corcoran, Memphis, Tennessee
 Ms. Jeanie Costanzo, Oak Forest, Illinois
 Mr. and Mrs. George Costas, Chicago, Illinois
 Mr. and Mrs. Edward T. Cotham, Jr., Houston, Texas
 Mrs. John S. Coulson, Evanston, Illinois
 Ms. Pamela Courtial, Newport Beach, California
 Mr. and Mrs. Philip Couture, Lakeside, California
 M. Gregoire Couturier, Fontainebleau, France
 Mr. David Mark Covill, Rosemont, Illinois

HONOR ROLL OF MEMBERS AND DONORS**Annual Members (\$35 – \$49) (cont.)**

Mr. Thomas William Coyle and Ms. Sally S. Coyle, Lake Bluff, Illinois
 Mr. Ralph P. Craig, Amherst, Massachusetts
 Ms. Hazel M. Cramer, Darien, Illinois
 Ms. Sicily Crawley, Berkley, Michigan
 Mr. and Mrs. Edward Cucci, Lincolnshire, Illinois
 Mr. William Currie, Salisbury, Vermont
 Ms. Jasmin W. Cyril, Morris, Minnesota
 A. Dahlquist, Gothenburg, Sweden
 Ms. Genevieve Daniels, Chicago, Illinois
 Mr. Bill J. Darden, Chicago, Illinois
 Mr. Robert Koos and Ms. Diane Dau-Koos, Kenosha, Wisconsin
 Sidney and Freda Davidson, Chicago, Illinois
 Professor Anna Morpurgo Davies, Oxford, United Kingdom
 Ms. Carol Davis, Cudahy, Wisconsin
 Ms. Deborah Davis, Chicago, Illinois
 Mr. and Mrs. George W. Davis, Chicago, Illinois
 Mr. Robert E. Davis, Waco, Texas
 Ms. Julia M. Dawson, Farmers Branch, Texas
 Leslie and Helen De Groot, Chicago, Illinois
 Ms. Maybrit S. De Miranda, Chicago, Illinois
 Ms. Catherine Deans-Barrett, Northbrook, Illinois
 Dr. R. H. Deibel, Nokomin, Florida
 Ms. Sara Hilary Dell, Chicago, Illinois
 Mr. and Mrs. Paul A. Demkovich, Schererville, Indiana
 Mr. Robert Demos, Chicago, Illinois
 Mr. Raymond L. Den Adel, Rockford, Illinois
 Mrs. Doris Devine, Chicago, Illinois
 Mrs. Peggy Dewey, Kent, United Kingdom
 Ms. Darlene L. Dielle, Cicero, Illinois
 Ms. Caitlin Dillon, East Lansing, Michigan
 Dr. Frank W. Dobbs, Evanston, Illinois
 Ms. Shirlee Doft, Hollywood, Florida
 Mr. Thomas E. Dolezal, Goldsmith, Indiana
 Mr. and Mrs. John Donovan, Wilmette, Illinois
 Ms. Karol Dougherty, Kansas City, Missouri
 Mr. Jim Douglas III, Chicago, Illinois
 Mr. and Mrs. Jim Douglas, Jr., Chicago, Illinois
 Mrs. Edmond L. d'Ouille, Evergreen Park, Illinois
 Dr. and Mrs. Robert M. Dowben, Providence, Rhode Island
 Mr. David Kyrle Down, Mount Colah, Australia
 Dr. and Mrs. Louis F. Draganich, Chicago, Illinois
 Ms. Ellen M. Dran, DeKalb, Illinois
 Mr. and Mrs. John Dreibelbis, Evanston, Illinois
 Mrs. Ernst H. Dreyfuss, Chicago, Illinois
 Mr. Stewart Driller, New York, New York
 Mr. Kenneth Drobeno, Chicago, Illinois
 Mrs. Anne Dunham, Pomona, California
 Ms. Sally S. Dunham, Westport, Connecticut
 Mr. Michael Dunkin, Chicago, Illinois

Annual Members (\$35 - \$49) (cont.)

Dr. John E. Duro, Fort Dodge, Iowa
 Ms. Penelope Dussias, Arlington Heights, Illinois
 Dr. and Mrs. Jarl E. Dyrud, Chicago, Illinois
 Ms. Jane Earle, Denver, Colorado
 Mr. David Eckert, Chicago, Illinois
 Ms. Delores J. Eckrich, Denver, Colorado
 Mrs. Kay Egger, Springfield, Ohio
 Mrs. Nancy A. Elliott, Otter Tail, Minnesota
 Mr. Chris Ellis, Kirkland, Washington
 Mr. Stephen A. Ellis, Rockford, Illinois
 Ms. Kathleen D. Ellison, Jasper, Indiana
 Ms. Cajsa J. Elo, Chicago, Illinois
 Ms. Christine End, Hempstead, New York
 Ms. Margarette L. Erdman, Madison, Wisconsin
 Ms. Ann Esse, Sioux Falls, South Dakota
 Mrs. Doris E. Evans, Des Plaines, Illinois
 Mr. and Mrs. Gordon Q. Evison, Chicago, Illinois
 Ms. Janet K. Fagan, Deerfield, Illinois
 Mr. John Cochrane and Ms. Beth Fama, Chicago, Illinois
 Mr. and Mrs. Ugo Fano, Chicago, Illinois
 Mr. Paul Fatula, Chicago, Illinois
 Mr. Michael Fellers, Burr Ridge, Illinois
 Mrs. Phyllis Therrio Fenton, Jacksonville, Illinois
 Mr. Luis Fierro, Chicago, Illinois
 Mrs. John T. Fillicaro, Des Plaines, Illinois
 Mrs. Annie Laurie Fish, Chicago, Illinois
 Mr. and Mrs. Gerald F. Fitzgerald, Jr., Inverness, Illinois
 Mrs. Harold M. Florsheim, Northbrook, Illinois
 Richard and Elizabeth Flury, Naperville, Illinois
 Ms. Laura Forgey, Tracy, California
 Dr. Lucy Fortson, Chicago, Illinois
 Mr. and Mrs. John L. Foster, Evanston, Illinois
 Ms. Tara Fowler, Chicago, Illinois
 Mr. and Mrs. Jacob L. Fox, Chicago, Illinois
 Mrs. Anne R. Frank, Bellaire, Texas
 Mr. Lawrence P. Frank, Chicago, Illinois
 Judith A. Franke, Lewistown, Illinois
 Mr. and Mrs. Richard J. Franke, Chicago, Illinois
 Mr. and Mrs. Jay Frankel, Chicago, Illinois
 Mr. and Mrs. Raymond Fredrick, Stuart, Florida
 Mr. and Mrs. Paul E. Freehling, Chicago, Illinois
 Mr. Jon Davies Freiler, Bethany, Connecticut
 Mr. and Mrs. Stephen Fried, Kingston, Massachusetts
 Mrs. Joan Friedman, Chicago, Illinois
 Mr. Wolfgang Frye, Belgium
 Mr. and Mrs. Perry L. Fuller, Winnetka, Illinois
 Ms. Mariana Furieux, Buenos Aires, Argentina
 Mr. Robert C. Gaffaney, Algonquin, Illinois
 Mr. James B. Galen, Homewood, Illinois

HONOR ROLL OF MEMBERS AND DONORS**Annual Members (\$35 – \$49) (cont.)**

Mr. and Mrs. Richard E. Galen, Homewood, Illinois
 Adam and Marla Gamoran, Madison, Wisconsin
 Mr. Rick Gann and Ms. Virginia Dickerson, Indianapolis, Indiana
 Mr. W. Randall Garr, Santa Barbara, California
 Mr. Robert V. Garvey and Ms. Dana M. Hokin, Chicago, Illinois
 Mr. Hermann Gasche, Paris, France
 Ms. Leanna Gaskins, San Francisco, California
 Mr. Daniel L. Gastaldi, Bloomfield, New Jersey
 Professor John T. Gaubatz and Mrs. Kathryn Ball Gaubatz, Coral Gables, Florida
 Ms. Lenora Gauldin, Tulsa, Oklahoma
 Mr. John G. Gay, Hinsdale, Illinois
 Ms. Rosalee Gentile, Oak Park, Illinois
 Professor Gilbert Ghez, Chicago, Illinois
 Ms. Alice Gibson, Chicago, Illinois
 Ms. Deborah Lynn Gillaspie, Chicago, Illinois
 Ms. Terry Gillespie, Flossmoor, Illinois
 Ms. Brenda Gilmer, Helena, Montana
 Ms. Irene Dorotea Glasner, Chicago, Illinois
 Mr. Alfred Glasser, Chicago, Illinois
 Mr. Ronald Glaze, Los Altos, California
 Ms. Doris Glicklich, New York, New York
 Mr. and Mrs. Norman Gold, Chicago, Illinois
 Ethel Frank Goldsmith, Chicago, Illinois
 Ms. Louise Ahrndt Golland, Chicago, Illinois
 Ms. Angela M. Gonzales, West Chicago, Illinois
 Dr. Andrew H. Gordon, Oakland, California
 Mrs. Evelyn Ruskin Gordon, Chicago, Illinois
 Ms. Nancy Gould, Hammond, Indiana
 Mr. James M. Govoni, Malden, Massachusetts
 Mr. Robert Gowland, Chicago, Illinois
 Mr. and Mrs. Darby Gragg, Chicago, Illinois
 Ms. Erynn Gray, Cedar Rapids, Iowa
 Mr. Matt Greby, Chicago, Illinois
 Beatrice C. Green and Elizabeth Hitz, Nashotah, Wisconsin
 Mr. Jonathan Green and Ms. Joy Schochet, Chicago, Illinois
 Mrs. Miriam Greenblatt, Highland Park, Illinois
 B. Herold Griffith, M.D., Evanston, Illinois
 Mr. Edmund P. Grondine, Jr., Burr Hill, Virginia
 Mr. David Grosz, Los Angeles, California
 Robert and Jane Grutz, Houston, Texas
 Mr. David Guillory, Lake Charles, Louisiana
 Ms. Margaret S. Gulley, Bay Village, Ohio
 Mr. Charles Gunn, Chicago, Illinois
 Mrs. Eleanor A. Guralnick, Chicago, Illinois
 Mr. Leo S. Guthman, Chicago, Illinois
 Ms. Joanna H. Gwinn, Evanston, Illinois
 Dr. Bernard Haberstroh, Kitchener, Ontario, Canada
 Jacqueline R. Haffenberg, Chicago, Illinois
 Mrs. Howard G. Haffenberg, Winnetka, Illinois

Annual Members (\$35 – \$49) (cont.)

Ms. Jane Davis Haight, Napa, California
 Mr. John A. Halbeck, Lyons, Illinois
 Ms. Barbara Hale, Park Ridge, Illinois
 Dr. Karen Hale, Newbury, Ohio
 Mrs. Robert A. Hall, Chicago, Illinois
 Mr. and Mrs. Philip Halpern, Chicago, Illinois
 Ms. Barbara Harcourt, Milroy, Indiana
 Mr. Ira Hardman
 Ms. Patty A. Hardy, Woodside, California
 Dr. W. Benson Harer, San Bernardino, California
 Professor Timothy P. Harrison, Toronto, Ontario, Canada
 Mr. and Mrs. E. Houston Harsha, Winnetka, Illinois
 Mr. Earl Hart, Milwaukee, Wisconsin
 Mr. John Hart and Ms. Kimerly Rorschach, Chicago, Illinois
 Mr. and Mrs. Robert B. Hartfield, Chicago, Illinois
 Robert and Ronne Hartfield, Chicago, Illinois
 Ms. Joan Hartman, Chicago, Illinois
 Mrs. J. A. Havel, Park Ridge, Illinois
 Mr. and Mrs. David C. Hawley, Winnetka, Illinois
 Mr. Nissim Hay, Chicago, Illinois
 Mr. John Haynik, Napanee, Ontario, Canada
 Mr. Arthur Heberer, SCU, Ferdinand, Indiana
 Mr. and Mrs. James J. Heckman, Chicago, Illinois
 Mr. Jerry Heckman, Morton Grove, Illinois
 Mr. and Mrs. William D. Heer, Glenview, Illinois
 Ms. Jennifer L. Hegedus, Chicago, Illinois
 Ms. Lenore Heiman, Streamwood, Illinois
 Mrs. Arles Hendershott-Love, Rockford, Illinois
 Mr. Robert F. Hendrickson, Princeton, New Jersey
 Mr. Tom Henneberry, Montgomery, Illinois
 The Reverend Richard Henshaw, Rochester, New York
 Mr. and Mrs. T. Donald Henson, Jr., Chicago, Illinois
 Mr. F. Robert Herbst, Chicago, Illinois
 Mr. Joel Hernandez
 Mr. and Mrs. William Herron, Chicago, Illinois
 C. A. Hertenstein, Cary, North Carolina
 Mr. Charles Herzer, New York, New York
 Dr. Charlotte C. Herzog, Evanston, Illinois
 Mr. Karl B. Hill, Forsyth, Georgia
 Mr. and Mrs. Fred M. Hillbruner, Chicago, Illinois
 Mr. and Mrs. Roger Hilpp, La Grange, Illinois
 Ms. Judith K. Hines, Vienna, Virginia
 Mr. John Hobgood, Chicago, Illinois
 Mrs. Carleton T. Hodge, Bloomington, Indiana
 Ms. Joanmarie Hofmann, Wesley Chapel, Florida
 Mr. and Mrs. John A. Holabird, Jr., Chicago, Illinois
 Mr. and Mrs. John G. Holden, Evanston, Illinois
 Ms. Susan T. Hollis, Syracuse, New York
 Mr. Thomas K. Holmquest, Oak Park, Illinois

HONOR ROLL OF MEMBERS AND DONORS**Annual Members (\$35 – \$49) (cont.)**

Dr. William Walter Holt and Dr. Heidi M. Koenig, Chicago, Illinois
 Mr. George Holub, Riverside, Illinois
 Ms. Jean Hontz, Niceville, Florida
 Dr. J. H. Hoogeweg, Markham, Illinois
 Rev. Elizabeth Hopp-Peters and Mr. Kurt Peters, Evanston, Illinois
 Mr. John Horn and Ms. Elizabeth Kelley, Oak Forest, Illinois
 Mrs. Leonard J. Horwich, Chicago, Illinois
 Jane Hough and Norma Hough, Sandwich, Illinois
 Mrs. Cynthia B. House, Arlington Heights, Illinois
 Mr. and Mrs. Joseph Howicz, Park Ridge, Illinois
 Mr. and Mrs. Paul Huckelberry, Chicago, Illinois
 Mr. Richard Smith Hughes, Ridgecrest, California
 Ms. Patricia Hume, Chicago, Illinois
 Ms. Jane C. Hunt, Chicago, Illinois
 Mr. and Mrs. Marion P. Hunt, Park Ridge, Illinois
 Professor Irene Winter, Cambridge, Massachusetts
 Ms. Cheri K. Hutchins, Anchorage, Alaska
 Mr. and Mrs. Alan Hutchinson, Chicago, Illinois
 Ms. Lois Hutchinson, Chicago, Illinois
 Mr. and Mrs. Thomas Illing, Hoboken, New Jersey
 Dr. and Mrs. Henry S. Inouye, Chicago, Illinois
 Mr. and Mrs. Marvin Isenstein, Highland Park, Illinois
 Mr. Anthony Ivcevic, Jr., San Diego, California
 Mr. and Mrs. Michael Y. Iwanaga, Chicago, Illinois
 Mr. and Mrs. Philip W. Jackson, Chicago, Illinois
 Mrs. Sandra Jacobsohn, Chicago, Illinois
 Mrs. Elise Jacobson, Chicago, Illinois
 Mr. Jeffrey A. Jaeger, Bayside, Wisconsin
 Mr. and Mrs. Richard D. Jaffe, Chicago, Illinois
 Mrs. Phyllis Jagiello, Des Moines, Iowa
 Ms. Judith E. Jahant, Evanston, Illinois
 Jeff and Jill Jahns, Chicago, Illinois
 Miss Alice James, Chicago, Illinois
 Mr. T. G. Harry James, London, United Kingdom
 Mrs. Gayle S. Janowitz, Chicago, Illinois
 Mr. Lawrence E. Jarchow, Chicago, Illinois
 Mr. Richard Lewis Jasnow, Baltimore, Maryland
 Dr. William R. Jeffery, Silver Spring, Maryland
 Ms. Fran Jennaro, Milwaukee, Wisconsin
 Mrs. William R. Jentes, Chicago, Illinois
 Mr. and Mrs. William Jepsen, McHenry, Illinois
 Mrs. Jane Johnson, Denver, Colorado
 Dr. Donald Whitcomb and Dr. Janet H. Johnson, Chicago, Illinois
 Dr. Maurice Johnson, Chicago, Illinois
 Hayward and Felicia Jones, Rolling Meadows, Illinois
 Pamela Jordan, Chicago, Illinois
 Ms. Georgette Joseph, Chicago, Illinois
 Mr. and Mrs. Christopher P. Joyce, Wheaton, Illinois
 Rev. Professor Douglas Judisch, Fort Wayne, Indiana

Annual Members (\$35 – \$49) (cont.)

Mr. George Junker, Chicago, Illinois
 Mrs. E. C. Junkunc, Chicago, Illinois
 Mr. Richard W. Kaczor, Tukwila, Washington
 Jack and Shirley Kamen, Indianapolis, Indiana
 Mr. John W. Kannenberg, Milwaukee, Wisconsin
 Mr. Robert Kao, West Linn, Oregon
 Dr. and Mrs. Maulana Karenga, Los Angeles, California
 Dr. Norbert Karg, Bilkent-Ankara, Turkey
 Mr. Fred Kass, Brooklyn, New York
 Mr. and Mrs. Preston B. Kavanagh, Gaithersburg, Maryland
 Ms. Susanne Kawatsu, Plymouth, Wisconsin
 Mr. Scott Keith, Hammond, Indiana
 Mr. Kip Kelley, Glenview, Illinois
 Mr. Jim Kershner, Chicago, Illinois
 Ms. Janet Zell Kessler, Chicago, Illinois
 Ms. Laila S. Khalil, Syosset, New York
 Mr. Glen A. Khant, Chicago, Illinois
 Mr. James A. Kilgore, Sun Lakes, Arizona
 Mr. Jerome C. Kindred, Arlington, Virginia
 Mr. Sidney W. Kitchel, Lake Oswego, Oregon
 Mr. Kenneth A. Kitchen, Liverpool, United Kingdom
 Mr. Richard Klapper, Alvin, Texas
 Mrs. Barbara Klawans, Munster, Indiana
 Mr. and Mrs. Kenneth W. Klein, River Forest, Illinois
 Ms. Sara C. Klein, Chicago, Illinois
 Mr. Patrick Klimczyk, Chicago, Illinois
 Mr. Frank Kohout, Iowa City, Iowa
 Mr. Gwin Kolb, Chicago, Illinois
 Ms. Kathy Kopczynski, Corvallis, Oregon
 Ms. Evelyn Kopp, Clinton, North Carolina
 Ms. Nagwa Korashy, Chicago, Illinois
 Ms. Maurine E. Kornfeld, Los Angeles, California
 Shelley Korshak, M.D., Chicago, Illinois
 Mr. Peter J. Kosiba, Chicago, Illinois
 Mr. and Mrs. Nicholas M. Kotcherha, Buffalo Grove, Illinois
 Dr. John Joseph Kottra, Anchorage, Alaska
 Miss Aletha A. Kowitz, Arlington Heights, Illinois
 Waud H. Cracke and Lucia Villela Cracke, Chicago, Illinois
 Bryan and Marie Krakauer, Chicago, Illinois
 Dr. Arthur A. Krawetz, Evanston, Illinois
 Ms. Helen Snyder Kremers, Chicago, Illinois
 Ms. Carol Krenger, Chicago, Illinois
 Anne K. G. Kristensen, Lyngby, Denmark
 Mr. and Mrs. Peter Krivkovich, Chicago, Illinois
 Carole and Larry Krucoff, Chicago, Illinois
 John and Elizabeth Kubek, Lisle, Illinois
 Mr. John F. Kurey, Chicago, Illinois
 Ms. Joan Kuric, Chicago, Illinois
 Ms. Rita Kusevskis-Hayes, Cooks Hill, Australia

HONOR ROLL OF MEMBERS AND DONORS**Annual Members (\$35 – \$49) (cont.)**

Ms. Inliss W. Kyte, Los Angeles, California
 Victoria La Sala, Englewood, New Jersey
 Ms. Anne Marie Labelle, Laval, Quebec, Canada
 Mr. Edward Lace, Wilmette, Illinois
 Andre and Claire Lacoque, Chicago, Illinois
 Miss Henrietta C. Lake, Chicago Ridge, Illinois
 Mr. and Mrs. Owen Lamont, Chicago, Illinois
 Mr. Sam Lan, Larchmont, New York
 Ms. Melissa Landis-McFeeley, Kankakee, Illinois
 Mr. Charles Lang, Chicago, Illinois
 Ms. Harriet E. Lang, San Francisco, California
 Dr. Charles F. Lange, Evanston, Illinois
 Mr. Gary T. Lark and Mrs. Lilianna Sekilla-Lark, Chicago, Illinois
 Ms. Laura L. Larner-Farnum, Yorba Linda, California
 Mr. David L. Laske, Niles, Illinois
 Mr. Harold Lassers and Ms. Pamela Lassers, Elmhurst, Illinois
 The Rev. Nathaniel Lauriat, Sedona, Arizona
 Mrs. Charles Lawrence, Chicago, Illinois
 Ms. Donny Leamy and Ms. Cheryl Walker, Westmont, Illinois
 Mr. Morton L. Leavy, Roslyn Heights, New York
 Mr. and Mrs. Richard Lee, Holland, Pennsylvania
 Mr. and Mrs. Trusten P. Lee, Clarendon Hills, Illinois
 Dr. and Mrs. Erle V. Leichty, Media, Pennsylvania
 Ms. Cher S. Lemel, Chicago, Illinois
 Dr. Richard W. Lenk, Jr., Paramus, New Jersey
 Ms. Sara Leonard, Chicago, Illinois
 Dr. and Mrs. Leonard H. Lerner, West Bloomfield, Michigan
 Mr. Morris Levine, St. Petersburg, Florida
 Mr. Steve Levitan, Brooklyn, New York
 Mr. Daniel E. Lewis, Jr., La Porte, Indiana
 Ms. Consuelo LeZama, Lombard, Illinois
 Mr. James Yuanxin Li, San Francisco, California
 Professor Avra Liakos, De Kalb, Illinois
 Mr. James Lichtenstein, Chicago, Illinois
 Mr. and Mrs. William Liebrock, Algonquin, Illinois
 Mr. Robert B. Lifton and Ms. Carol Rosofsky, Chicago, Illinois
 Dr. and Mrs. David E. Lindsey, Lafayette, California
 Mr. B. Orchard Lisle, Fort Worth, Texas
 Mr. and Mrs. Edward L. Lloyd, Libertyville, Illinois
 Ms. Elizabeth Lockwood, Chicago, Illinois
 Mr. J. P. Lockwood, Freeport, Illinois
 Ms. Beth Ann Lodal, Oak Park, Illinois
 Ms. Brienne Loftis, Dallas, Texas
 Mr. and Mrs. Thomas J. Logan, Carmel, California
 Mr. Gregory Longhini, Chicago, Illinois
 Ms. Marilyn Jean Lovik, Rochester, Minnesota
 Mr. Jo Desha Lucas and Ms. Johanna W. Lucas, Chicago, Illinois
 Mrs. Beatrice Lumpkin, Chicago, Illinois
 Mr. William B. Lundstrom, Glenview, Illinois

Annual Members (\$35 – \$49) (cont.)

Benoit Lurson, Loos, France
 Ms. Melea Lusk, Chicago, Illinois
 Mr. Gary Lyall, Willowbrook, Illinois
 Ms. Corinne Lyon, Chicago, Illinois
 Ms. Mary Lyons, Chicago, Illinois
 Mr. Andrew M. MacDonald, Santurce, Puerto Rico
 Ms. Abigail MacKenzie, Chicago, Illinois
 Mr. John Mahtesian, Chicago, Illinois
 Dr. Eugene I. Majerowicz, Los Angeles, California
 Mr. and Mrs. Moses M. Malkin, Sarasota, Florida
 Mrs. Adeline Malnekoff, Chicago, Illinois
 Ms. Marie T. Maltese, Baltimore, Maryland
 Dr. Sara Mandell, Tampa, Florida
 Ms. Leah Maneaty, Chicago, Illinois
 Mr. Naguib MANKarious, Chicago, Illinois
 Dr. Michelle I. Marcus, New York, New York
 Ms. Roberta G. Marks, New York, New York
 Michele and James Marquardt, Kalamazoo, Michigan
 Mr. Charles W. Martin, Sylvania, Georgia
 Ms. Victoria Martin, Chicago, Illinois
 Mr. Robert Masters, Santa Ana Heights, California
 Ms. Margaret S. Matchett, Chicago, Illinois
 Dr. and Mrs. Henry B. Matthews, Chicago, Illinois
 Mr. Dave Mausner, Oak Park, Illinois
 Mrs. Robert B. Mayer, Chicago, Illinois
 Mr. Charles E. Maynard, Chicago, Illinois
 Mr. William McAndrews, Tinley Park, Illinois
 Ms. Judy McClain, Duncan, Oklahoma
 Gary and Haven McClung, Arlington Heights, Illinois
 Dr. and Mrs. James B. McCormick, Lincolnwood, Illinois
 John and Ann McDermott, Winnetka, Illinois
 Mrs. Marie Theresa McDermott, Chicago, Illinois
 Mr. Dennis Hoby McDonald, Parker, Colorado
 Mr. Matthew McDonald, River Forest, Illinois
 Barbara and Douglas McDonough, Homewood, Illinois
 Ms. Eileen T. McGeehan, Evanston, Illinois
 Bernard and Patricia McGinn, Chicago, Illinois
 Mr. and Mrs. Robert McGinness, Homewood, Illinois
 Mr. and Mrs. Richard McGinnis, Chicago, Illinois
 Eunice H. McGuire, Chicago, Illinois
 Mr. Peter McHugh, Elizabeth, New Jersey
 Ms. Sandra McIntosh, Chicago, Illinois
 Mr. Glen V. McIntyre, Kingfisher, Oklahoma
 Ms. Edith G. McLaren, Winnetka, Illinois
 Mr. Hugh McLean, Berkeley, California
 Ms. Carolyn McMurray, Chicago, Illinois
 Mr. and Mrs. Ben Meeker, Chicago, Illinois
 Ms. Sharon Megson, Banbury, United Kingdom
 James Engelthaler and Miss Rebecca F. Mellinger, Chicago, Illinois

HONOR ROLL OF MEMBERS AND DONORS**Annual Members (\$35 – \$49) (cont.)**

Ms. Machteld J. Mellink, Haverford, Pennsylvania
 Dr. Grier H. Merwin, Brookline, Massachusetts
 Mr. and Mrs. John Merza, Chicago, Illinois
 Dr. Carol Meyer, Chicago, Illinois
 Mr. Glenn R. Meyer, San Jose, California
 Mr. and Mrs. Henry Meyer, Shreveport, Louisiana
 Mr. G. Scott Mikalauski, Chicago, Illinois
 Mrs. Caryl J. Mikrut, Orland Park, Illinois
 Mr. Dean Miller, Chicago, Illinois
 Mr. Gene Miller, Madison, Wisconsin
 Greg and Carol Miller, Chicago, Illinois
 Mr. Walter R. Miller, Homewood, Illinois
 Kathleen and Steven Mineck, Elmhurst, Illinois
 Ms. Kari Mitchell, Chicago, Illinois
 Mr. J. Y. Miyamoto, Los Angeles, California
 Mr. Wayne N. Moles, Santa Clara, California
 Mr. Robert Monastero, San Diego, California
 Mr. and Mrs. John Monson, Wheaton, Illinois
 Ms. Vivian B. Morales, Miami, Florida
 Dr. and Mrs. George Morgan, Joliet, Illinois
 Joseph A. and June J. Moriarty, Kingsport, Tennessee
 Mr. and Mrs. John H. Morris, Canada
 Mr. Stefan Muenger, Bern, Switzerland
 Mr. Arthur H. Muir, Jr., Westlake Village, California
 Mr. and Mrs. Jay F. Mulberry, Chicago, Illinois
 Ms. Kathryn T. Muller, Brooklyn, New York
 Mr. Richard F. Murphy and Ms. Maribeth Murphy, Wilmette, Illinois
 Mr. Michael J. Murrin, Chicago, Illinois
 Mr. Danny Murry, New York, New York
 Mr. Flavio La Morticella and Ms. Barbara Myers, Evanston, Illinois
 Mr. and Mrs. Frédéric and Patricia Murat, Chicago, Illinois
 Ms. Marion Myers, Chicago, Illinois
 Mrs. Marcia B. Nachtrieb, Palos Park, Illinois
 Mr. and Mrs. Robert Naftzger, Chicago, Illinois
 Dr. Mistuo Nakamura, Okayama-ken, Japan
 Ms. Demetria D. Nanos, Chicago, Illinois
 Mr. Bassam H. Naoum, Chicago, Illinois
 Ms. Ann Napolitano, Hillside, Illinois
 Ms. Sittlekmat Nebyatmerut, Chicago, Illinois
 Ms. Candace Nelson, Rochester, New York
 Mr. Douglas Nelson, Powell, Wyoming
 Mr. Jeffrey N. Nelson, Bismarck, North Dakota
 Mr. Olaf Nelson, LaGrange, Illinois
 Mr. and Mrs. Otto C. Nerad, Western Springs, Illinois
 Rosemarie and Martin Nestmann, Kassel, Germany
 Dr. John G. New, Chicago, Illinois
 James Newmark and Eileen S. Newmark, Chicago, Illinois
 Mr. Roy Ng, Skokie, Illinois
 Mr. John Nichols, Nederland, Colorado

Annual Members (\$35 - \$49) (cont.)

Madame Sylvette Nicolini, Chicago, Illinois
 Mr. Tom Nielsen, Simi Valley, California
 Shin-Ich Nishimoto, Tokyo, Japan
 Dr. Edward Brovarski and Ms. Del Nord, Brookline, Massachusetts
 Ms. Linda Nordenberg, Chicago, Illinois
 Ms. Karen Nordheim, Chicago, Illinois
 Karen Norris, Waterloo, Iowa
 Mrs. Beth Noujaim, New York, New York
 Ms. Catherine Noujaim, Baltimore, Maryland
 Ms. Faith Marie Nykiel, Chicago, Illinois
 John, Lesley, and Victoria O'Brien, Middlesex, United Kingdom
 Mr. Dennis O'Connor, Chicago, Illinois
 Mrs. Nancy McGrath O'Connor, Chicago, Illinois
 Ms. Anne Cabot Ogilvy, Philadelphia, Pennsylvania
 Ms. Zarina Eileen O'Hagin, Chicago, Illinois
 Mr. David Andrew Oliva, Gibraltar, Spain
 Mr. Lee R. Olson, Katonah, New York
 Mr. Gary A. Oppenhuis and Ms. Mary E. Jordison, Flossmoor, Illinois
 Mr. Charles Orzechoskie and Ms. Eileen O'Malley, Chicago, Illinois
 Mr. Gary M. Ossewaarde, Chicago, Illinois
 Mr. Stuart O'Steen, Boulder, Colorado
 Dr. and Mrs. Jacques Ovadia, Chicago, Illinois
 Dr. Jane H. Overton and Mr. George W. Overton, Chicago, Illinois
 Mrs. Dorothy S. Packer, Ph.D., Cambridge, Massachusetts
 Mr. Samuel M. Paley, Buffalo, New York
 Mrs. Origene J. Paquette, Southbridge, Massachusetts
 Mr. Hiram Patterson, Carrollton, Texas
 Mrs. Denise G. Paul, Chicago, Illinois
 Dr. Robert Paulissian, Highland Park, Illinois
 Mr. Richard Paulsen, Elmhurst, Illinois
 Ralph and Carolyn Payer, Chicago, Illinois
 Mr. Donald Payne, Chicago, Illinois
 Father James Pizat-Delys, St. Marys, Kansas
 Dr. William G. Peacher, P.C., Riverside, California
 Mr. William H. Peck, Detroit, Michigan
 Dr. and Mrs. Richard E. Pedersen, Claremont, California
 Ms. Judith Peebles, Nashville, Tennessee
 Mr. Jose Roberto Pellini, Sao Paulo, Brazil
 Ms. Sandra Pendell, Racine, Wisconsin
 Ms. Paulette T. Penzes, Middleburg Heights, Ohio
 Mr. David W. Pepper, Arvada, Colorado
 Ms. Mary-Ellen Perley, Edmonton, Alberta, Canada
 Mr. and Mrs. Richard Persons, Oswego, Illinois
 Mildred Othmer Peterson, Chicago, Illinois
 Ms. Melanie Petrosky, Hammond, Indiana
 Mai Phan, Chicago, Illinois
 Ms. Mai Phan, Chicago, Illinois
 Mrs. Edward Phillips, Chicago, Illinois
 Mr. Peter Piccione and Ms. Myrna Lane, Charleston, South Carolina

HONOR ROLL OF MEMBERS AND DONORS**Annual Members (\$35 – \$49) (cont.)**

Mr. Raymond E. Pifer, Jamestown, North Carolina
 Mr. S. Richard Pincus and Janice E. Linn, Chicago, Illinois
 Mr. James Piojda, Racine, Wisconsin
 Ms. Holly Pittman, Philadelphia, Pennsylvania
 Dr. and Mrs. George Pollock, Chicago, Illinois
 Mr. and Mrs. Charles F. Pope, Jr., Cincinnati, Ohio
 Ms. Barbara A. Porter, New York, New York
 Ms. Diane M. Posner, Chicago, Illinois
 Dale Postema, Griffith, Indiana
 Ms. Dawn M. Prena, Woodstock, Illinois
 Mr. Frank E. Preston, Santa Rosa, California
 Mr. Michael Prokop, Rover Grove, Illinois
 Mr. Dmitri Proussokov, Moscow, Russia
 Mr. Michael J. Pulos, Dunedin, Florida
 Mrs. Sheila Putzel, Chicago, Illinois
 Mr. Richard J. Quigley, Chicago, Illinois
 Mr. Robert Andresen and Ms. Elaine Quinn, Chicago, Illinois
 Ms. Della Quinn-Carter, Terre Haute, Indiana
 Mr. Bruce Donald Rabe, Broomfield, Colorado
 The Doctors Alice and Emanuel Racher, Park Forest, Illinois
 David and Lois Rakov, Chicago, Illinois
 Mr. Phillip E. Ramsey, Lexington, South Carolina
 Dr. Ruth Ann G. Ramsey, Chicago, Illinois
 Mr. Francis B. Randall, New York, New York
 Mr. James M. Ratcliffe, Chicago, Illinois
 Mr. and Mrs. Bill Rawlins, Palatine, Illinois
 Professor and Mrs. John D. Ray, Cambridge, United Kingdom
 Mrs. Linda L. Reading, Wheeling, Illinois
 Dr. Carol Ann Redmount, Berkeley, California
 Ms. Jane Reese, Bremerton, Washington
 Mr. and Mrs. G. M. Regnier, Westville, Indiana
 Mr. William Reinke, South Bend, Indiana
 Mr. William C. S. Remsen, Dover, Massachusetts
 Professor Johannes Renger, Berlin, Germany
 Mrs. Merle Reskin, Northbrook, Illinois
 Mr. David Reynolds, Fontana, California
 David Rice and Carol Jackson Rice, Barrington, Illinois
 Mr. and Mrs. Harold A. Richman, Chicago, Illinois
 Mr. Mitchell S. Rieger and Mrs. Pearl H. Rieger, Chicago, Illinois
 Mr. and Mrs. Martin Riesebrodt, Chicago, Illinois
 Mr. and Mrs. Burton Rissman, Chicago, Illinois
 Dr. Robert Ritner, Chicago, Illinois
 Dr. and Mrs. Kenneth C. Robbins, Chicago, Illinois
 Dr. Gary L. Robertson, Chicago, Illinois
 Professor John F. Robertson, Mount Pleasant, Michigan
 Mr. and Mrs. Jon Robison, Littleton, Colorado
 Ms. Margaret Ann Roche, Sycamore, Illinois
 Ms. Leebertha Alisa Rogers, Los Angeles, California
 Professor W. Rollig, Tubingen, Germany

Annual Members (\$35 – \$49) (cont.)

Ms. Judith G. Rom, Chicago, Illinois
 Bruce L. Rosen, Ph.D., Newton, Massachusetts
 Mrs. Donald C. Ross, Tucson, Arizona
 Mr. Anthony Rowell, Chicago, Illinois
 Ms. Ingrid Rowland, Chicago, Illinois
 Mr. and Mrs. Sidney Rowland, Lawrenceville, New Jersey
 Ms. Karen S. Rubinson, New York, New York
 Ms. Alice Rubio, Chicago, Illinois
 Ms. Lisa Ruddick, Chicago, Illinois
 Dr. and Mrs. Charles J. Runner, Chicago, Illinois
 Ms. Kim Ryholt, Greve, Denmark
 Mrs. Lee Sagers, Chicago, Illinois
 Mrs. Martin A. Salmon, Clarendon Hills, Illinois
 Ms. Dori Saltzman, West Henrietta, New York
 Dr. and Mrs. Charles E. Samec, Oak Park, Illinois
 Dr. Bonnie Sampsell, Chapel Hill, North Carolina
 Dr. Gonzalo Sanchez, Sioux Falls, South Dakota
 Ms. Johanna G. Sande, Skokie, Illinois
 Ms. Lucie Sandel, Chicago, Illinois
 Ms. Roxanne Sanders-Gagnon, Fort Worth, Texas
 Mr. Steven Sanora, El Monte, California
 Mr. Paul Sansone, Montclair, New Jersey
 Mr. Berge Sarrafian, Morton Grove, Illinois
 Dr. Shahan Sarrafian, Skokie, Illinois
 Mr. Carl F. Schaefer, Flint, Michigan
 Mr. R. Thomas Schaub, Pittsburgh, Pennsylvania
 Dr. and Mrs. Lawrence J. Scheff, Chicago, Illinois
 Mr. and Mrs. Nathan Schlessinger, M.D., Chicago, Illinois
 Ms. Denise Schmandt-Besserat, Austin, Texas
 Mr. Paul Schoessow and Ms. Patricia Cavenee, Downers Grove, Illinois
 Mr. Edward Schoolman, Brooklyn, New York
 Mr. and Mrs. Hans Schreiber, Chicago, Illinois
 Ms. Julie Schuler, Chicago, Illinois
 Mr. William Biederman and Ms. Patricia Schulman, Chicago, Illinois
 Dean and Donna Schultz, Arlington Heights, Illinois
 Mr. and Mrs. Fred Schultz, Ligonier, Pennsylvania
 Mr. Warren C. Schultz, Chicago, Illinois
 Dr. and Mrs. Gebhard F. Schumacher, Homewood, Illinois
 Mr. William C. Schutzius, Cincinnati, Ohio
 Albert and Jane Schwuchow, Chicago, Illinois
 Mr. Harold N. Scoblow, Chicago, Illinois
 Mr. Theodore N. Scontras, Saco, Maine
 Ms. Jane Ayer Scott, West Newton, Massachusetts
 Mr. F. Richard Seddon, McIntosh, New Mexico
 Mr. Richard Sefton, Bakersfield, California
 Mr. Barre Seid, Chicago, Illinois
 Mr. Ivan Selin, Washington, District of Columbia
 Ms. Marilyn Serafin, Burbank, California
 Mr. William Seward, Alexandria, Virginia

HONOR ROLL OF MEMBERS AND DONORS**Annual Members (\$35 – \$49) (cont.)**

Mr. Vincent F. Seyfried, Garden City, New York
 Dr. Byron E. Shafer, Yonkers, New York
 Mr. and Mrs. William Shapiro, Wilmette, Illinois
 Mr. Patrick J. Shaughnessy, St. Louis, Missouri
 Mrs. John Shearman, Grand Rapids, Ohio
 Mr. and Mrs. Alan M. Shefner, Chicago, Illinois
 Ms. Rose Mary Sheldon, Lexington, Virginia
 Dr. Peter G. Sheldrick, Chatham, Ontario, Canada
 Ms. Cynthia C. Shepard, Stanford, California
 Mrs. Albert W. Sherer, Chicago, Illinois
 Ms. Karol Shewmaker, Chicago, Illinois
 Mr. and Mrs. Melvyn J. Shochet, Chicago, Illinois
 Ms. Jamie Shoemaker, Huntington, New York
 Ms. Barbara J. Shorf, San Diego, California
 Mr. and Mrs. Walter and Shirley Shostack, Dayton, Ohio
 Mr. Marcel Sigrist, Jerusalem, Israel
 Ms. Janet Silvers and Ms. Teri Tebelman, Homewood, Illinois
 Peter and Charlotte Silvers, Lake Mills, Wisconsin
 Dr. Sheryl Simon, Sewickley, Pennsylvania
 Ms. Emel Singer, Chicago, Illinois
 Mr. Mark Singer, Phoenix, Arizona
 Dr. Peter D. Skiff, Annandale-on-Hudson, New York
 The Reverend Richard J. Sklba, Milwaukee, Wisconsin
 Mrs. H. Brooks Smith, Lake Forest, Illinois
 Ms. Joanne Smith, Bath, Ohio
 Dr. Keith Smith, Middleburg Heights, Ohio
 Dr. Joe Smolik, Switzerland
 Mr. John Vance Snow, Calgary, Alberta, Canada
 Ms. Barbara J. Speers, Kansas City, Missouri
 Mr. and Mrs. Harold J. Spelman, Warrenville, Illinois
 Mrs. D. Spencer, Templestowe, Australia
 Miss Nancy A. Spencer, Chicago, Illinois
 Mrs. Barbara M. Sperry, Flossmoor, Illinois
 Mrs. Elizabeth Spiegel, Chicago, Illinois
 Dr. Wolfgang and Mrs. Dorothy Spindler, Park Ridge, Illinois
 Mr. and Mrs. Richardson L. Spofford, Chicago, Illinois
 Esther Sprenkel-Segel, Ph.D., Wilmette, Illinois
 Ms. Gwendolyn Square, Chicago, Illinois
 Mr. Russell W. Stamper, Sr., Milwaukee, Wisconsin
 Ms. Jean Starshak, Wayne, Illinois
 Mrs. Helaine Staver, Chicago, Illinois
 Mr. John Gerald Steenken, Chicago, Illinois
 Ms. Kim Steffen, Chicago, Illinois
 Ms. Leslie Kiku Steinfeld, Chicago, Illinois
 Mr. and Mrs. C. Lester Stermer, Chicago, Illinois
 Mr. Kent Sternitzke, Fort Worth, Texas
 Ms. Nellie R. Stickle, Batavia, Illinois
 Houston and Diana Stokes, Chicago, Illinois
 Mr. David Allan Stoudt, Clackamas, Oregon

Annual Members (\$35 – \$49) (cont.)

Mr. Donald Stout, River Forest, Illinois
 Dr. Joe P. Strain, Fort Worth, Texas
 Dr. Patricia Strama, Princeton, Illinois
 Mrs. Edward Stransky, Lake Forest, Illinois
 David G. and W. Elane Streets, Darien, Illinois
 Ms. Bernadette M. Strnad, Berwyn, Illinois
 Clay W. Stuckey, DDS, Bedford, Indiana
 Mr. Clement Studebaker, Chula Vista, California
 Mr. and Mrs. Robert Sudol, Wheaton, Illinois
 Rabi and Aida Sulayman, Chicago, Illinois
 Ms. Jan Summers-Duffy, Blooming Grove, New York
 Mr. Charles W. Suran, Flagstaff, Arizona
 Ms. Claudia E. Suter, Chicago, Illinois
 Mr. and Mrs. Richard Swanson, Chicago, Illinois
 Mr. William Swanson, Princeton, Illinois
 Dr. Ronald F. G. Sweet, Don Mills, Ontario, Canada
 Ms. Noel L. Sweitzer, Los Angeles, California
 Mr. and Mrs. Stuart Swenson, Dyer, Indiana
 Mr. John Taaffe, Chicago, Illinois
 Mr. Daniel Taelman, Froyennes, Belgium
 Mrs. Faye E. Takeuchi, Vancouver, British Columbia, Canada
 Mr. Robert M. Taras, Las Vegas, Nevada
 Ms. Betsy Teeter, San Francisco, California
 Mrs. Shirley Teeter, Ransomville, New Jersey
 Mr. George M. Telthorst, Allen, Texas
 K. Beth Temple-Council, Chattanooga, Tennessee
 Helen and Robert Tentler, M.D., River Forest, Illinois
 Ms. Karen Terras, Chicago, Illinois
 Mr. David Testen and Ms. Nancy L. Dray, Skokie, Illinois
 Mrs. Richard J. Thain, Chicago, Illinois
 Ronald and Linda Thisted, Chicago, Illinois
 Mr. Gregory Thomas, Grandview, Texas
 Randy and Barbara Thomas, Chicago, Illinois
 Mr. and Mrs. John Thompson, Carefree, Arizona
 Ms. Laura Tilling, Camdenton, Missouri
 Mr. John J. Tintiangco, Lincolnshire, Illinois
 Ms. Patricia Tomeske, Bloomfield, New Jersey
 Marianne Tomita McDonald, Oakland, California
 Ms. Carol N. Tompkins, Chicago, Illinois
 Mr. and Mrs. Robert J. Tonos, Chicago, Illinois
 Levon K. Topouzian, M.D. and Nancy B. Topouzian, Ph.D., Skokie, Illinois
 Mr. Jose M. Torres, Torrente, Spain
 Karim and Aamirah Tourk, Evanston, Illinois
 Mrs. Judy Trenkle, Lombard, Illinois
 Miss Janice Trimble, Chicago, Illinois
 Dr. Harry and Mrs. Marjorie Trosman, Chicago, Illinois
 Mr. Daniel C. N. Tsui and Ms. Ann G. Tsui, Maineville, Ohio
 Mr. Sugihiko Uchida, Japan
 Jia-Sheng Ueng, Tainan, Taiwan, R.O.C.

HONOR ROLL OF MEMBERS AND DONORS**Annual Members (\$35 – \$49) (cont.)**

Mr. Frank Underbrink, Libertyville, Illinois
 Ms. Marilyn Underwood, Chicago, Illinois
 Ms. Cheri Unruh, Malin, Oregon
 Ms. Lynne F. Ur, Ellicott City, Maryland
 Mr. and Mrs. Warran A. Urbik, Machesney Park, Illinois
 Dr. Levan Z. Urushadze, Tbilisi, Georgia
 Ms. Rosemary Vallehy, Chicago, Illinois
 Ms. Allyn Van Alstyne, San Francisco, California
 Dr. Karel Van Dam, Muiden, Netherlands
 Mrs. Norma van der Meulen, Chicago, Illinois
 Margaret van Wissink, Mount Prospect, Illinois
 Ms. Pamela J. Vance, Gary, Indiana
 Ms. Alexandra Varga, Catskill, New York
 Mr. William Vartorella, Camden, South Carolina
 Mr. K. R. Veenhof, Heemstede, Netherlands
 Mr. and Mrs. Robert K. Vincent, Jr., Cairo, Egypt
 Mr. John Vinci, Chicago, Illinois
 Mr. Gregory L. Vogel, Downers Grove, Illinois
 Dr. and Mrs. Howard F. Vos, Philadelphia, Pennsylvania
 Mr. Tom Vosmer, Fremantle, Australia
 Mr. Earl V. Voudren, Springfield, Massachusetts
 Mrs. Elizabeth Wagner, Leawood, Kansas
 Ms. Mary Eleanor Wall, Elmhurst, Illinois
 Ms. Doris Waller, Chicago, Illinois
 Nancy I. Walsh, Tiburon, California
 Mrs. Dolph Walter, Flossmoor, Illinois
 Dr. Robert I. Walter and Frieda Asqhari Walter, Arlington Heights, Illinois
 Mr. and Mrs. Irving Ward, Sr., Palos Park, Illinois
 Mr. Kelvin Ward, Chicago, Illinois
 Mr. Ralph E. Ward, Aguanga, California
 Dr. Nancy E. Warner, Pasadena, California
 Mr. and Mrs. Kenneth W. Watson, Shepherdstown, West Virginia
 Mr. Dick Watson, Naperville, Illinois
 Ms. Zell Watson, Brooklyn, New York
 Ms. JoAnn Way, Salada, North Carolina
 Dr. Patrick G. Jobe and Dr. Andrea Lynn Wayda, Westfield, New Jersey
 Don Webb and Rosemary Webb, Austin, Texas
 Ms. Meredith Webb, Dover, Ohio
 Beverly A. Weber, Orinda, California
 Ms. Lisa Wedeen, Chicago, Illinois
 Mrs. Joyce Weil, Chicago, Illinois
 Ms. Nathalie Weil, Chicago, Illinois
 Ms. Melanie Weill, Redington Beach, Florida
 Mr. and Mrs. Norman Weinberg, Chicago, Illinois
 Mr. and Mrs. David B. Weisberg, Cincinnati, Ohio
 Ms. Ruth F. Wenger, Evanston, Illinois
 Professor Rebecca West, Chicago, Illinois
 Mr. Arthur P. Wheatley, East Chicago, Indiana
 Mrs. Scott Whitcomb, Decatur, Georgia

Annual Members (\$35 – \$49) (cont.)

Ms. Anna M. White, Terre Haute, Indiana
 Mrs. Jill A. White, Taneytown, Maryland
 Mr. Thomas White, Pittsburgh, Pennsylvania
 Mr. John F. Whitehouse, St. Ives, Australia
 Ms. Pamela Wickliffe, Chicago, Illinois
 Mr. and Mrs. William D. Wiener, Chicago, Illinois
 Dr. Henry Wildberger, Mount Prospect, Illinois
 Dr. and Mrs. Philip C. Williams, Chicago, Illinois
 Dr. and Mrs. F. Thomas Wilson, Princeton, New Jersey
 Mr. Robert L. Wilson, Millerville, Maryland
 Ms. Diane Windisch, Clarendon Hills, Illinois
 Dr. and Mrs. Jerome A. Winer, Chicago, Illinois
 Dr. and Mrs. Robert Wissler, Chicago, Illinois
 Mr. Earl N. Witzler, Waterville, Ohio
 Ms. Paula Wolff, Chicago, Illinois
 Jane F. Woodruff, Pleasant Valley, Missouri
 Mr. and Mrs. John Woodworth, Taos, New Mexico
 Mr. James D. Worrell, Corpus Christi, Texas
 Ms. Geneen Wright, Chicago, Illinois
 Ms. Rita P. Wright, New York, New York
 Mr. Hung Wu, Chicago, Illinois
 Ms. Sel Yackley, Chicago, Illinois
 Ms. Sara R. Yerkes, Santa Barbara, California
 Mrs. Deborah M. Yerman, Citrus Springs, Florida
 Ms. Susan N. Young, La Grange, Illinois
 Mr. Tim Zane, Aurora, Illinois
 Mr. and Mrs. Frank Zapolis, Evergreen Park, Illinois
 Mr. Emil Edward Zbella, Chicago, Illinois
 Mrs. Anna M. Zelisko, Hinsdale, Illinois
 Ms. Diane Zendejas
 Mr. and Mrs. Alfred M. Ziegler, Chicago, Illinois
 Ms. Jane M. Zimmer, Chicago, Illinois
 Robert and Sheila Zimmer, Oak Lawn, Illinois
 Mr. Steve Zollman, Berkeley, California

Student Members (\$15–\$34)

Ms. Ariana Almajan, Chicago, Illinois
 Ms. Maria Aragon, Chicago, Illinois
 Ms. Leslie Emily Bailey, Chicago, Illinois
 Mr. Lee Baker, Chicago, Illinois
 Ms. Gail Barnes, Chicago, Illinois
 Mr. Colin Barth, Chicago, Illinois
 Ms. Betul Basaran, Chicago, Illinois
 Mr. Terry Becker, Orland Park, Illinois
 Mr. Michael Robert Beetley, Chicago, Illinois
 Ms. Caroline Berg, Appleton, Wisconsin
 Mr. Andrew Bielakowski, Toronto, Ontario, Canada
 Ms. Jocelyn Boor, Shorewood, Wisconsin
 Mr. Alejandro Botta, Chicago, Illinois

HONOR ROLL OF MEMBERS AND DONORS**Student Members (\$15 – \$34) (cont.)**

Ms. Anne Broadbridge, Chicago, Illinois
 Mr. Jeffrey Burns, Chicago, Illinois
 Ms. Heath Cabat, Chicago, Illinois
 Mr. Dennis Robert Mallick Campbell, Chicago, Illinois
 Mr. Jim Chalgren, St. Paul, Minnesota
 Mr. Thomas L. Chapman, Jr., Chicago, Illinois
 Ms. Catharine Clark, Chicago, Illinois
 Ms. Alexandra Cordts, Chicago, Illinois
 Ms. Laura Culbertson, Chicago, Illinois
 John Darnell, Ph.D. and Deborah Darnell, Hamden, Connecticut
 Mr. Trenell Davis, Waukegan, Illinois
 Ms. Simrit Dhesi, Chicago, Illinois
 Mr. Benajmin Diebold
 Ms. Elena Dodge, Chicago, Illinois
 Mr. Radcliffe Edmonds, Chicago, Illinois
 Ms. Eloise Eilert, Aurora, Illinois
 Ms. Helene Felman, Arcadia, California
 Ms. Heather Ruth Felton, Chicago, Illinois
 Ms. Laurie Flentye, New York, New York
 Ms. Edith Foster, Chicago, Illinois
 Ms. Elizabeth Friedman, Chicago, Illinois
 Deborah Friedrich, Chicago, Illinois
 Mr. Francois Gaudard, Chicago, Illinois
 Ms. Faye Deborah Gershon, Chicago, Illinois
 Ms. Leland Frances Giovannelli, Chicago, Illinois
 Mr. Marvin Gordon, Chicago, Illinois
 Mr. Andrew Graham, Dallas, Texas
 Ms. Debbi Grenn-Scott, San Mateo, California
 Mr. Harold Hays, Chicago, Illinois
 Mr. Choukri Heddouchi, Chicago, Illinois
 Ms. Amy A. Hendrick, Plainfield, Illinois
 Mr. Markus Hilgert, Marburg, Germany
 Mr. Eng Seng Ho, Lexington, Kentucky
 Mr. Steve Hoskins, Hoffman Estates, Illinois
 Ms. Carrie A. Hritz, Chicago, Illinois
 Ms. Anne Margaret Igoe, Memphis, Tennessee
 Ms. Antoinette T. Jackson, Oak Park, Illinois
 Ms. Kallie Keith, Chicago, Illinois
 Dr. Korosh Khalili, Toronto, Ontario, Canada
 Mr. Benjamin Hansel Kleine, Chicago, Illinois
 Mr. Neil Laird, Chicago, Illinois
 Christoph A. Landa, San Diego, California
 Mr. Ricky Leavell, Chicago, Illinois
 Mr. Phillip Lenihan, San Francisco, California
 Ms. Dove Lindgren, Chicago, Illinois
 Ms. Shelley Luppert-Barnard, Chicago, Illinois
 Mr. Jerry Lyon, Tucson, Arizona
 Mr. Daniel Marmer, Chicago, Illinois
 Mr. Travers McCord, Ontario, Canada

Student Members (\$15 – \$34) (cont.)

Mr. Michael J. McInerney, Chicago, Illinois
 Mr. Michael D. Meacham, Berkeley, California
 Mr. Ian Moyer, Chicago, Illinois
 Ms. Diane Carole Mumma-Wakabayashi, Chicago, Illinois
 Mr. Lawrence J. Mykytiuk, Lafayette, Indiana
 Mr. Mark Nabong, Chicago, Illinois
 Ms. Sandra Lynne Napolitan, Chicago, Illinois
 Ms. India J. Newlin, West York, Illinois
 Ms. Yoko Nishimura, Chicago, Illinois
 Ms. Alexandra O'Brien, Chicago, Illinois
 Mr. Hratch Papazian, Chicago, Illinois
 Mr. Miller Prosser, Chicago, Illinois
 Ms. Emily Quirke, Chicago, Illinois
 Mr. Francisco A. Ramos III, Chicago, Illinois
 Ms. Beth Allyn Richel, Lemont, Illinois
 Ms. Ronnica Robbins, Muncie, Indiana
 Mr. Jarrell Robinson and Ms. Pamela Johnson, Chicago, Illinois
 Ms. Kira Lynn Robison, Littleton, Colorado
 Mr. Frederick R. Royce, North Ferrisburgh, Vermont
 Ms. Adrienne Seely, Chicago, Illinois
 Ms. Roshanak Shaeri-Eisenlohr, Chicago, Illinois
 Ms. Farkhondeh Shayesteh, Chicago, Illinois
 Mr. Randy Shonkwiler, Chicago, Illinois
 Ms. Tamara Lynn Siuda, Chicago, Illinois
 Britta Sneep, Oro Valley, Arizona
 Mr. David T. Stewart, Berkeley, California
 Ms. Katherine Alexandra Strange, Chicago, Illinois
 Ms. Lynn Swartz, Los Angeles, California
 Mr. Jeremy Taub, Chicago, Illinois
 Mr. Jan Mark Tavernier, Chicago, Illinois
 Mr. Jonathan Tenney, Chicago, Illinois
 Ms. Mari Anita Torres, Chicago, Illinois
 Mr. Jason Ur, Chicago, Illinois
 Mr. Jan Verstraete, Chicago, Illinois
 Mr. John Walton, Chicago, Illinois
 Ms. Justine Way, Chicago, Illinois
 Mr. Michael Gary Wechsler, Chicago, Illinois
 Mr. Ken Woodside, Galveston, Texas

GIVERS OF GIFT MEMBERSHIPS

The following supporters gave gift memberships to the Oriental Institute in 1998/99.

Mr. Beau Abdenour, Shaker Heights, Ohio
 Ms. Lynn A. Baril, Culver City, California
 Raymond D. Tindel and Gretel Braidwood, Chicago, Illinois
 Mr. Alan R. Brodie, Chicago, Illinois
 Ms. Dorathea Bucher, Dublin, Ohio
 Mr. Tim Cashion, Chicago, Illinois
 Mr. and Mrs. E. Eric Clark, Sierra Madre, California

HONOR ROLL OF MEMBERS AND DONORS**Givers of Gift Memberships (cont.)**

Mrs. Geraldine D. Eilert, Aurora, Illinois
 The Professors Gene and Michèle Gragg, Chicago, Illinois
 Miss Mary Jane Gray, Homewood, Illinois
 Mr. and Mrs. Albert F. Haas, Chicago, Illinois
 Mr. John Hobgood, Chicago, Illinois
 Ms. Susan C. Hull, Chicago, Illinois
 Dr. Donald Whitcomb and Dr. Janet H. Johnson, Chicago, Illinois
 Ms. Karen J. Kuehner, Glenview, Illinois
 Mr. Steve Levitan, Brooklyn, New York
 Mr. J. Brett McClain, Chicago, Illinois
 Dr. William Brice McDonald, Chicago, Illinois
 Ms. Emily Napolitano, Chicago, Illinois
 Ms. Mary Jane Nigro, Chicago, Illinois
 Mrs. Beth Noujaim, New York, New York
 Ms. Alexandra O'Brien, Chicago, Illinois
 Mr. Scott Petry, New Philadelphia, Ohio
 Mr. Michael Rom, Chicago, Illinois
 Mr. Richard Schoolman, Brooklyn, New York
 Mr. and Mrs. Walter and Shirley Shostack, Dayton, Ohio
 Dr. and Mrs. William Sosnowsky, Grosse Pointe, Michigan
 Ms. Emily Teeter, Chicago, Illinois
 Mr. Jason Ur, Chicago, Illinois
 Ms. Lila Valinoti, Chicago, Illinois
 Ms. Justine Way, Chicago, Illinois
 Mrs. Barbara Breasted Whitesides, Newton, Massachusetts
 Mr. John L. Wier and Ms. Elizabeth B. Wier, Naperville, Illinois
 Ms. Margaret Wrigley, Oakland, California

DONOR HONOR ROLL**\$100,000 and Above**

Mrs. Elizabeth Baum, Chicago, Illinois
 Mr. and Mrs. Robert J. Braidwood, La Porte, Indiana
 Mrs. Joseph N. Grimshaw, Wilmette, Illinois
 Polk Bros. Foundation Inc., Chicago, Illinois
 Sara Lee Corporation, Chicago, Illinois
 Dr. and Mrs. Sharukin Yelda, Chicago, Illinois

\$10,000 – \$99,999

Bank One, Chicago, Illinois
 Chicago Community Trust, Chicago, Illinois

\$10,000 – \$99,999 (cont.)

The Coleman Foundation, Inc., Chicago, Illinois
 Anthony T. and Lawrie C. Dean, Long Grove, Illinois
 Elizabeth Morse Charitable Trust, Chicago, Illinois
 Elizabeth Morse Genius Charitable Trust, Chicago, Illinois
 Ernst & Young LLP, Chicago, Illinois
 Dr. Marjorie M. Fisher, Bloomfield Hills, Michigan
 The J. Paul Getty Trust, Brentwood, California
 Trust Estate of Walter Gibbs, Grosse Pointe Farms, Michigan
 Mr. and Mrs. Richard Gray, Chicago, Illinois
 Dr. Boyd E. Hayward, Paradise Valley, Arizona
 Thomas and Linda Heagy, Chicago, Illinois
 Robert and Janet Helman, Chicago, Illinois
 Mr. and Mrs. Marshall M. Holleb, Chicago, Illinois
 The Institute for Aegean Prehistory, New York, New York
 The John Nuveen Company, Chicago, Illinois
 KPMG LLP, Chicago, Illinois
 The LaSalle Banks, Chicago, Illinois
 Daniel A. Lindley and Lucia Woods Lindley, Evanston, Illinois
 Lloyd A. Fry Foundation, Chicago, Illinois
 David and Carlotta Maher, Chicago, Illinois
 Mrs. Barbara Mertz, Frederick, Maryland
 Morgan Stanley & Co. Incorporated, New York, New York
 National Geographic Society, Washington, District of Columbia
 Philip Morris Companies, Inc., New York, New York
 Mr. David K. and Mrs. Crennan M. Ray, Kansas City, Missouri
 Regional Information Tech. & Software Eng. Center, Egypt
 Estate of Martha F. Robinson, Chicago, Illinois
 Mr. Norman J. and Mrs. Alice E. Rubash, Evanston, Illinois
 John Mark Rudkin Charitable Foundation, France
 St. Lucas Charitable Foundation, Hinsdale, Illinois

\$5,000 – \$9,999

Muammer and Bedriye Akgun, Naperville, Illinois
 Mrs. James W. Alsdorf, Winnetka, Illinois
 Mr. and Mrs. Albert F. Haas, Chicago, Illinois
 Institute of Turkish Studies Incorporated, Washington, District of Columbia
 Mrs. Glen A. Lloyd, Libertyville, Illinois
 Mr. Henry and Mrs. Janet R. Meyer, Shreveport, Louisiana
 Mr. and Mrs. Roger Nelson, Glencoe, Illinois
 The Northern Trust Company, Chicago, Illinois
 Miss Kathleen Picken, Chicago, Illinois
 Mr. and Mrs. Robert G. Schloerb, Chicago, Illinois
 Rev. John M. Sevick, Chicago, Illinois
 Ms. Emel Singer, Chicago, Illinois
 Mr. Gerald L. Vincent, Cortez, Colorado
 Brigitte Warning Watkins, Ph.D., Chicago, Illinois
 Ms. Sel Yackley, Chicago, Illinois

HONOR ROLL OF MEMBERS AND DONORS**\$1,000 – \$4,999**

Professor and Mrs. Robert Z. Aliber, Chicago, Illinois
 Mr. E. Ercan and Mrs. Asuman Alp, Naperville, Illinois
 Amsted Industries Foundation, Chicago, Illinois
 Mr. and Mrs. Ronald R. Baade, Winnetka, Illinois
 Bell Atlantic Foundation, Arlington, Virginia
 John and Esther Benjamin, Chicago, Illinois
 Mr. and Mrs. Thomas Bennett, New York, New York
 Raymond D. Tindel and Gretel Braidwood, Chicago, Illinois
 Ms. Margaret C. Brandt, Eminence, Kentucky
 Mr. Alan R. Brodie, Chicago, Illinois
 Mrs. Lalitha Chandrasekhar, Chicago, Illinois
 Chicago Bridge & Iron Foundation, Oak Brook, Illinois
 Judith and William Cottle, Winnetka, Illinois
 Ms. Marion Cowan, Evanston, Illinois
 Daniel F. & Ada L. Rice Foundation, Skokie, Illinois
 Mr. Lawrence R. and Mrs. Vicky C. Eicher, Falls Church, Virginia
 Mrs. Emily Huggins Fine, San Francisco, California
 Estate of Ernest L. Folk, Richmond, Virginia
 James and Margaret Fooman, Chicago, Illinois
 Mr. Wolfgang Frye, Belgium
 Mr. Paul Gerstley, Santa Monica, California
 Professor Fred Giles, Australia
 Mr. and Mrs. I. A. Grodzins, Chicago, Illinois
 Mr. Ernest A. Grunsfeld III, Highland Park, Illinois
 Ms. Louise Grunwald, New York, New York
 Dr. Henrietta M. Herbolsheimer, Chicago, Illinois
 Dr. David C. and Mrs. Betty S. Hess, Downers Grove, Illinois
 Roger and Jane Hildebrand, Chicago, Illinois
 Wayne J. Holman III, Glen Ellyn, Illinois
 Mr. Cordell W. Hull, Atherton, California
 Mr. Roger David and Mrs. Joyce R. Isaacs, Glencoe, Illinois
 Mr. Robert B. McDermott and Ms. Sarah P. Jaicks, Chicago, Illinois
 Mr. Jonathan Janott, Japan
 Dr. Donald Whitcomb and Professor Janet Johnson, Chicago, Illinois
 Mr. and Mrs. Ellis O. Jones, Sr., Sommerville, Massachusetts
 Mrs. Marjorie H. Buchanan Kiewit, Chestnut Hill, Massachusetts
 Ms. Erika S. Kuiper, Ottawa, Illinois
 Dr. Tuncer M. and Mrs. Alice K. Kuzay, Naperville, Illinois
 Professors Ayhan and Nicholas Lash, Naperville, Illinois
 Mr. H. Toby Markowitz, Roseville, Minnesota
 Ira and Janina Marks, Chicago, Illinois
 Mayer, Brown & Platt, Chicago, Illinois
 Merrill Lynch, Chicago, Illinois
 Mr. Merton H. and Mrs. Katherine Dusak Miller, Chicago, Illinois
 Mobil Foundation, Inc., Fairfax, Virginia
 Mr. Donald Oster, United Kingdom
 Mr. George and Mrs. Sarah P. Pagels, Jr., Chicago, Illinois
 Pennzoil Company, Houston, Texas
 Petty Foundation, Inc., Littleton, Colorado

\$1,000 – \$4,999 (*cont.*)

Pfizer Pharmaceuticals Group, Inc., New York, New York
 Mr. and Mrs. Robert F. Picken, Chicago, Illinois
 Miss M. Kate Pitcairn, Kempton, Pennsylvania
 J. M. and Semra Prescott, De Kalb, Illinois
 R. B. Industries Inc., Niles, Illinois
 Dr. Miriam Reitz Baer, Chicago, Illinois
 Mrs. Mualla Salievski, Darien, Illinois
 Dr. Bonnie Sampsell, Chapel Hill, North Carolina
 Mrs. Maurice D. Schwartz, Los Angeles, California
 Mr. Charlie Secchia, New York, New York
 Mr. Yuksel A. Selcukoglu, Naperville, Illinois
 Charles and Mary Shea, Wilmette, Illinois
 The Honorable George P. Shultz, Stanford, California
 Mr. Robert K. Smither, Hinsdale, Illinois
 Mr. and Mrs. Hugo F. Sonnenschein, Chicago, Illinois
 Mr. and Mrs. Solon Stone, Corvallis, Oregon
 Dr. and Mrs. Francis H. Straus II, Chicago, Illinois
 Dr. Ali G. Surek, Diamondhead, Mississippi
 Ms. Emily Teeter, Chicago, Illinois
 Ms. Melanie Weill, Redington Beach, Florida
 Mr. James Q. Whitman, New York, New York
 Ms. Carol J. Williams, Chicago, Illinois

\$500 – \$999

The Honorable James and Marjorie Akins, Washington, District of Columbia
 Archaeological Tours, New York, New York
 Bankers Trust Foundation, New York, New York
 Ms. Enid Barden, Bloomfield Hills, Michigan
 Mr. and Mrs. William F. Baxter, Mount Prospect, Illinois
 Dr. Judith Bensinger and Mr. Peter B. Bensinger, Lake Forest, Illinois
 Mr. William and Mrs. Florence Boone, Glencoe, Illinois
 Mrs. Cameron Brown, Lake Forest, Illinois
 Mr. Tim Cashion, Chicago, Illinois
 Mehmet B. and Aysen Civelek, Deerfield, Illinois
 Richard and Sally Cook, Richmond, Virginia
 Mr. John S. and Mrs. Jane R. Coulson, Illinois
 Ms. Mary Louise Cowan, Booth Bay Harbor, Maine
 Dr. Eugene D. and Dr. Kathryn Cruz-Urbe, Flagstaff, Arizona
 Ms. Cynthia Darnell, Mundelein, Illinois
 Peter and Katharine. Darrow, Brooklyn, New York
 Mr. George and Mrs. Betty L. Eden, Peoria, Illinois
 Mrs. Ann B. Fallon, Tucson, Arizona
 Ms. Linda Feinstone, New York, New York
 Mr. and Mrs. Jacob L. Fox, Chicago, Illinois
 Mr. and Mrs. Stephen Gates, Chicago, Illinois
 Mrs. Frances H. and Mr. Jack Getman, Fort Myers, Florida
 The Professors Gene and Michèle Gragg, Chicago, Illinois
 Ms. Jane Davis Haight, Napa, California
 Mr. and Mrs. William Harms, Alsip, Illinois

HONOR ROLL OF MEMBERS AND DONORS**\$500 – \$999 (cont.)**

Mrs. Myron Hokin, Chicago, Illinois
 Mr. and Mrs. Peter Homans, Chicago, Illinois
 J & H Marsh & McLennan, Inc., New York, New York
 Mr. Eugene Goldwasser and Ms. Deone Jackman, Chicago, Illinois
 Ms. Karen Jacobson, Bloomfield Hills, Michigan
 Mr. George and Mrs. Barbara Javaras, Chicago, Illinois
 Orhan Kaymakcalan, M.D., Burr Ridge, Illinois
 Mr. William Kistler, New York, New York
 Mr. Gregory Gene Knight, Chicago, Illinois
 Mr. and Mrs. Edward H. Levi, Chicago, Illinois
 Mrs. Vladimir S. Littauer, Syosset, New York
 Dr. John M. and Mrs. Amy Livingood, Bethesda, Maryland
 Sarah Meisels, Wheaton, Illinois
 Mrs. F. Richard Meyer III, River Forest, Illinois
 MidAmericArtsAlliance, Kansas City, Missouri
 Phillip and Barbara Miller, Oregon, Illinois
 Dr. Harlan R. Peterjohn, Bay Village, Ohio
 Mr. Keith Pomeroy, Bloomfield Hills, Michigan
 Dr. Erica Reiner, Chicago, Illinois
 Mr. and Mrs. F. Garland Russell, Jr., Columbia, Missouri
 Mr. Aladdin Saba, Egypt
 Mrs. Helen J. Schwarten, Evanston, Illinois
 Toni S. Smith, Chicago, Illinois
 Ms. Dorothy J. Speidel, Wilmette, Illinois
 Ms. Lowri Sprung, San Pedro, California
 Mr. Carl Sterr, Bloomfield Hills, Michigan
 Samuel and Ellen Stevens, Belmont, Massachusetts
 Mr. and Mrs. Kenneth Williams, Canada
 Ms. Judith A. Young, Milwaukee, Wisconsin

\$250 – \$499

Robert M. Ball, M.D., Amarillo, Texas
 Mr. John Batchelor, Houston, Texas
 Ms. Janice Brannon, Chicago, Illinois
 Mr. Bruce P. Burbage, Springfield, Virginia
 Mr. and Mrs. David De Bruyn, Seattle, Washington
 Ms. Ann Esse, Sioux Falls, South Dakota
 Sidney S. and Dorothy S. Foorman, Bloomington, Indiana
 Mr. and Mrs. John W. Fritz II, Kenilworth, Illinois
 Paul and Iris Goldstein, Chicago, Illinois
 Mr. and Mrs. Bruce K. Goodman, Northbrook, Illinois
 Mr. Charles W. Graham, Camden, Maine
 Mr. Norman and Mrs. Lieselotte Hessler, Mount Prospect, Illinois
 Ms. Lorena M. Holshoy, North Canton, Ohio
 Mr. Reinhardt H. Jahn, Riverside, Illinois
 Mr. and Mrs. George Joseph, Portland, Oregon
 Mr. and Mrs. H. David Kirby, Owings Mills, Maryland
 Mrs. Betty P. Kusch, Dallas, Texas
 Dr. Richard W. Lenk, Jr., Paramus, New Jersey

\$250 - \$499 (cont.)

Mr. and Mrs. Floyd Miller, Chicago, Illinois
 Mr. Robert Ralph and Ms. Lois Patricia Moeller, Evanston, Illinois
 Mr. Charles Nelson, Seattle, Washington
 Ms. Sandra Pendell, Racine, Wisconsin
 Mrs. Mualla Salievski, Darien, Illinois
 South Suburban Archaeological Society, Homewood, Illinois
 Mr. and Mrs. Joel Studebaker, Princeton, New Jersey
 Mr. and Mrs. Donald E. Sunderlin, Washington, Illinois
 Dr. Vefa and Ms. Terry Tarhan, Wilmette, Illinois
 Dr. David M. and Mrs. Mari D. Terman, M.D., Wilmette, Illinois

\$100 - \$249

Mr. and Mrs. Daniel L. Ables, Scottsdale, Arizona
 Mr. Coskun and Mrs. Ayse Z. Akan, Chicago, Illinois
 Thomas G. Akers, Ph.D. and Dr. Ann B. Akers, New Orleans, Louisiana
 Mary and Stanley Allan, Chicago, Illinois
 James and Susan Allen, Ridgefield, Connecticut
 Mr. Willis Ashley, Scottsdale, Arizona
 Mr. Roger Atkinson, Riverside, California
 Mr. and Mrs. Donald Aurand, Lancaster, Pennsylvania
 Professor and Mrs. William Baker, Santa Fe, New Mexico
 Marjorie C. Barnett, M.D., Chicago, Illinois
 Mr. George R. Bateman, Chicago, Illinois
 Ms. Jane E. Belcher, Chicago, Illinois
 Dr. Barbara Bell, Cambridge, Massachusetts
 Mr. Clive Davies and Ms. Phoebe Bennett, Arlington, Virginia
 Dr. Jerrold Stephen Cooper and Ms. Carol Bier, Baltimore, Maryland
 Glenn F. Boas, D.D.S., Chicago, Illinois
 Mr. and Mrs. James T. Bradbury, Knoxville, Tennessee
 Mr. Willard W. Brown, Jr., Bucksport, Maine
 Mr. Joseph D. Cain, Chicago, Illinois
 Mrs. Jeanny Canby, Bryn Mawr, Pennsylvania
 Caterpillar Foundation, Peoria, Illinois
 Claire Chamberlain, Houston, Texas
 Mr. Richard L. Chambers, Chicago, Illinois
 CIGNA Foundation, Philadelphia, Pennsylvania
 Mr. Harris H. Clark, Tempe, Arizona
 Ms. Cynthia Green Colin, New York, New York
 Dr. William Huntsman and Ms. Rosemary Cooper, Athens, Ohio
 Mr. George G. Costas III, Winston-Salem, North Carolina
 Ms. Alyce De Costa, Chicago, Illinois
 Dr. R. H. Deibel, Nokomin, Florida
 Mr. David Detrich, Mattituck, New York
 Mr. Franklin E. and Mrs. Millie M. Dillard, Jr., Honolulu, Hawaii
 Ms. Mary Dimperio, Washington, District of Columbia
 Dr. Erl and Mrs. Mildred Reinke Dordal, Chicago, Illinois
 Jean Du Rette, Egypt
 Mrs. Bettie Dwinell, Chicago, Illinois
 Mr. Paul Ehrenfest, Gulfport, Mississippi

HONOR ROLL OF MEMBERS AND DONORS**\$100 – \$249 (cont.)**

Mr. Frederick Elghanayan, New York, New York
 Mr. and Mrs. Jerome L. Ettelson, Chicago, Illinois
 Dr. Valerie Fargo, Midland, Michigan
 Mrs. Barry Benson Ferris, Israel
 Mr. Charles J. Fisher, Sioux City, Iowa
 Mr. and Mrs. Paul E. Freehling, Chicago, Illinois
 Mrs. Eleanor B. Frew, Flossmoor, Illinois
 Mrs. Irene G. Fulton, Los Altos Hills, California
 Mrs. Anne Roede Giddings, Cheshire, Connecticut
 Mrs. William H. Gofen, Chicago, Illinois
 Mr. Frederick J. and Mrs. Patricia J. Graboske, Rockville, Maryland
 Mrs. Anita and Dr. Nathaniel D. Greenberg, Highland Park, Illinois
 Miss Elizabeth E. Griffin, Winter Haven, Florida
 Dr. and Mrs. Roy Grinker, Chicago, Illinois
 Mr. and Mrs. Richard Harwood, Colorado Springs, Colorado
 Mr. Edmund Hayes, Jr., Portland, Oregon
 Walter E. Heller Foundation, Chicago, Illinois
 Mr. Robert F. Hendrickson, Princeton, New Jersey
 John P. and Jan Isaacs Henry, Colorado Springs, Colorado
 Mr. Charles Herzer, New York, New York
 Dr. Cho-yun Hsu, Pittsburgh, Pennsylvania
 Ms. Lyric Hughes, Chicago, Illinois
 Mr. Arthur T. Hurley, Napa, California
 International Business Machines Corporation, Armonk, New York
 Mrs. Sandra Jacobsohn, Chicago, Illinois
 Dr. Steven and Dr. Funda Kahn, Northbrook, Illinois
 Mr. Guriz and Mrs. Gulden Kapani, Chicago, Illinois
 Mr. Turgay and Mrs. Feryal Kaya, Long Grove, Illinois
 Neil J. and Diana Hunt King, Chicago, Illinois
 Mr. Henry H. and Mrs. Annie A. Kohl, Media, Pennsylvania
 Mrs. Margaret B. Kovacs, Chicago, Illinois
 Mr. Donald Kraft, Skokie, Illinois
 Mr. Irvin Kraft, Houston, Texas
 Mr. William J. and Mrs. Blair S. Lawlor III, Kenilworth, Illinois
 Mr. and Mrs. Richard Lee, Holland, Pennsylvania
 Mr. Robert A. Lindquist, Jr., Des Plaines, Illinois
 Mr. Lou L. Long, Bellevue, Washington
 Mr. and Mrs. Jo Desha Lucas, Chicago, Illinois
 Lucent Technologies Foundation, New York, New York
 Manchester Ancient Egypt Society, United Kingdom
 Mr. H. George and Mrs. Roberta G. Mann, Highland Park, Illinois
 Ms. Masako I. Matsumoto, Chicago, Illinois
 Ms. Eva C. May, New Rochelle, New York
 Mrs. R. E. Maynard, Chicago, Illinois
 Mr. Willis McDonald IV, Cody, Wyoming
 Professor Piotr Michalowski, Ann Arbor, Michigan
 Mr. and Mrs. William L. Morrison, Chicago, Illinois
 Ms. Holly J. Mulvey, Evanston, Illinois
 Mrs. Marcia B. Nachtrieb, Palos Park, Illinois

\$100 - \$249 (cont.)

Ms. Mary B. Naunton, Chicago, Illinois
 Mr. John P. Nielsen, Lombard, Illinois
 Mr. Dale George Niewoehner, Rugby, North Dakota
 Mr. Jeffrey F. Omohundro, Richmond, Virginia
 Paragano Management Corp., Springfield, New Jersey
 Mr. Larry Paragano, Springfield, New Jersey
 Mrs. Denise G. Paul, Chicago, Illinois
 Dr. Richard E. and Mrs. Nelda N. Pedersen, Claremont, California
 Norman and Lorraine Perman, Chicago, Illinois
 Mr. and Mrs. Jeffrey Pommerville, Scottsdale, Arizona
 Ms. Diane M. Posner, Chicago, Illinois
 Mr. William C. S. Remsen, Dover, Massachusetts
 Mrs. Ludwig Rosenberger, Chicago, Illinois
 Ms. Randi Rubovits-Seitz, Washington, District of Columbia
 Mrs. Treadwell Ruml, Kansas City, Missouri
 Ms. Janice B. Ruppel, Chicago, Illinois
 Ms. Diane M. Ruszczuk, Lancaster, California
 Mr. Harold and Mrs. Deloris Sanders, Chicago, Illinois
 Ms. Lillian H. Schwartz, Chicago, Illinois
 Ms. Jane Ayer Scott, West Newton, Massachusetts
 Mr. Zekir Share, Aurora, Illinois
 Ms. Emma Shelton and Ms. Florence Kate Millar, Bethesda, Maryland
 Mrs. Constance J. Sidles, Seattle, Washington
 Mr. Michael Simon, Cleveland Heights, Ohio
 Dr. Henry D. Slosser, Altadena, California
 Mr. and Mrs. Kenneth Small, Irvine, California
 Ms. Mary Small, Kensington, California
 Ms. Louise Tennent Smith, Columbus, Georgia
 Mr. Piotr Steinkeller, Sudbury, Massachusetts
 Mr. and Mrs. Harry M. Stern, Bloomington, Illinois
 Phyllis and Thomas Sternau, New York, New York
 William M. Sumner and Kathleen J. Sumner, Columbus, Ohio
 Mrs. John F. Tatum, Oxford, Mississippi
 Mr. Gregory Thomas, Grandview, Texas
 Randy and Barbara Thomas, Chicago, Illinois
 Mr. John E. and Mrs. Eva L. Townsend, Winnetka, Illinois
 Mrs. Nilgul N. Turkseven, Milwaukee, Wisconsin
 United Educational & Charitable Fdn. Inc., Elkins, New Hampshire
 Barbara H. VanBaalén, East Lansing, Michigan
 Mustafa Vidinli, M.D., S.C., Chicago, Illinois
 Ms. Sharon Wagenknecht, Streator, Illinois
 Mr. LeRoy Weber, Jr., Rio Vista, California
 Mr. John R. Weiss, Wilmette, Illinois
 Mr. and Mrs. Edward F. Wente, Chicago, Illinois
 Mr. John A. White, Jr., Atlanta, Georgia
 Mr. Terry G. Wilfong, Ann Arbor, Michigan
 Bruce and Pat Williams, Chicago, Illinois
 Mr. Jack E. Wilson, Marietta, Georgia
 Mr. Paul Walker and Ms. Karen L. Wilson, Chicago, Illinois

HONOR ROLL OF MEMBERS AND DONORS**\$100 – \$249 (cont.)**

Dr. Wendall W. Wilson, Chicago, Illinois
 Ms. Joan W. Wofford, Boston, Massachusetts
 Mr. and Mrs. Kenneth K. Wong, Chicago, Illinois
 Mr. and Mrs. John J. Wright, Cupertino, California
 Mr. Robert M. Wulff, Washington, District of Columbia
 Mr. Frank Zapolis, Evergreen Park, Illinois

\$1 – \$99

Dr. Maria Ahlstrom, Chicago, Illinois
 Ms. Senel Aksu, Turkey
 Ms. Linda Landis Andrews, Chicago, Illinois
 Mr. Ahmet R. Argon, Evanston, Illinois
 Armstrong Foundation, Lancaster, Pennsylvania
 Mr. Phillip Rychel and Ms. Sharon Avery, Tulsa, Oklahoma
 Dr. Gabor Badics, Austria
 Mrs. Richard W. Baum, Chicago, Illinois
 Ms. Roxanne W. Beardsley, Bloomfield, Connecticut
 Russell L. and Joanne M. Bears, Vermillion, Ohio
 Ms. Joy Beck, Chicago, Illinois
 Ms. Gillian Ruth Bentley, United Kingdom
 Ms. Marilyn McC. Black, Glencoe, Illinois
 Dr. Elizabeth Mara Bloch-Smith, Bala Cynwyd, Pennsylvania
 The Boeing Company, Seattle, Washington
 Dr. Constance Bonbrest, Chicago, Illinois
 Mrs. Jerald C. Brauer, Chicago, Illinois
 Mr. and Mrs. Robert Brooker, Longwood, Florida
 Ms. Gayle C. Brownell, Hermosa Beach, California
 Mr. Parks Campbell, Fort Worth, Texas
 Dr. and Mrs. Lewis W. Coppel, Chillicothe, Ohio
 Professor Lorelei H. Corcoran, Memphis, Tennessee
 Ms. Hazel M. Cramer, Darien, Illinois
 Ms. Cheri Cruikshank, Castro Valley, California
 Ms. Evangeline P. Dallas, Chicago, Illinois
 Ms. Katherine M. Damitz, Wheaton, Illinois
 Mr. Walter E. De Lise, Indian Head Park, Illinois
 Ms. Munevver Mina Demren, Chicago, Illinois
 Mr. Fuat and Mrs. Senel Dikici, Ottawa, Illinois
 Mrs. Edmond L. d'Ouille, Evergreen Park, Illinois
 Ms. Margaret Hart Edwards, Lafayette, California
 Leila M. Foster, J.D., Ph.D., Evanston, Illinois
 Jay and Marlene Frankel, Chicago, Illinois
 Mrs. Barbara D. Frey, Chicago, Illinois
 Mrs. Anita Fuchs, Chicago, Illinois
 Ms. Elizabeth Fuchs, Huntington, New York
 Adam and Marla Gamoran, Madison, Wisconsin
 Mr. Aylmer M. Gifford, Chicago, Illinois
 Dr. and Mrs. John Gills, Elmhurst, Illinois
 Mr. Ronald Glaze, Los Altos, California
 Dr. Samuel and Mrs. Lesha Greengus, Cincinnati, Ohio

\$1 - \$99 (cont.)

Ms. Mary Ann Greenhill, Pomona, California
 Richard and Mary Harter, Chicago, Illinois
 Ms. Helen Hift, Madison, Wisconsin
 Mr. Thomas K. Holmquest, Oak Park, Illinois
 Mr. John Horn and, Oak Forest, Illinois
 Ms. Dorothy H. Hovey, Arlington, Virginia
 Mr. and Mrs. Edward Hunt, Long Beach, California
 Mr. Sabit Inan and Mrs. Czatdama Omam, Chicago, Illinois
 Miss Alice James, Chicago, Illinois
 Mr. Lawrence E. Jarchow, Chicago, Illinois
 Mrs. Samantha Johnson, Chicago, Illinois
 Mr. and Mrs. Christopher P. Joyce, Wheaton, Illinois
 George and Jeanne Junker, Chicago, Illinois
 Ms. Stacy Karzen, Highland Park, Illinois
 Dr. and Mrs. Raja Khuri, Evanston, Illinois
 Mr. and Mrs. Gunnar Klintberg, Old Greenwich, Connecticut
 Ms. Carol L. Kocan, Chicago, Illinois
 Mr. Peter J. Kosiba, Chicago, Illinois
 Dr. Arthur A. Krawetz, Evanston, Illinois
 Mr. Alvin W. and Mrs. Norma B. Ladd, Rancho Palos Verdes, California
 Mr. David M. and Mrs. Betsy I. Laucks, Red Lion, Pennsylvania
 Mr. John Lawrence, Ann Arbor, Michigan
 Ms. Linda Le Blanc, Rockville, Maryland
 Ms. Judith Licata, Delavan, Wisconsin
 Ms. Gail W. and Mr. Thomas J. Lowry, Berkeley, California
 M and M Enterprises, Pasadena, California
 Mr. Donald H. Mayo, Norfolk, Virginia
 Helen Metzner, Ann Arbor, Michigan
 Mr. Lawrence and Ms. Isabelle Meyer, Glendale, California
 Memduh Mete Moran, Chicago, Illinois
 Mrs. Millard E. Murphy, Pasadena, California
 Dr. Theodore M. Norton, Saratoga, California
 Mrs. Beth Noujaim, New York, New York
 Mr. Humphrey T. Olinde, Jr., New Roads, Louisiana
 Ms. Elizabeth O'Toole, Downers Grove, Illinois
 Dr. Herbert H. Paper, Cincinnati, Ohio
 Mr. Bob Partridge, United Kingdom
 Mrs. Astrid M. Perez, Long Grove, Illinois
 Phoenix Mutual Life Insurance Co., Hartford, Connecticut
 Mr. and Mrs. John Platt, Northfield, Illinois
 Ms. Penny K. Polson, Winfield, Illinois
 Joseph and Jo Ann Putz, Palos Heights, Illinois
 Mr. Joseph A. and Mrs. Jo Ann Putz, Palos Heights, Illinois
 Ms. Milunka Radkevic, Milwaukee, Wisconsin
 Louise Lee Reid, Clarendon Hills, Illinois
 Mr. and Mrs. Robert A. Reiss, Falls Church, Virginia
 Mr. and Mrs. Charles S. Rhyne, Portland, Oregon
 Mrs. Morris M. Rossin, Chicago, Illinois
 Ms. Bridget E. Rowley, Chicago, Illinois

HONOR ROLL OF MEMBERS AND DONORS**\$1 – \$99 (cont.)**

Mr. and Mrs. Irv Schauer, Scottsdale, Arizona
 Mrs. Mary Jean and Dr. Sidney Schulman, Chicago, Illinois
 Ms. Virginia B. Schulz, Palo Alto, California
 Dr. Robert C. and Mrs. Eugenia A. M. Seamans, Jr., Beverly Farms, Massachusetts
 Mr. Michael L. Jorn and Mrs. Caroline Seymour-Jorn, Shorewood, Wisconsin
 Daniel Shapiro, M.D., Evanston, Illinois
 Ms. Joan N. Shapiro, Evanston, Illinois
 Ms. Hannah Simon, New York, New York
 Ms. Susan L. Singer-Katz, Deerfield, Illinois
 Mrs. Penelope W. Slough, Grosse Pointe Farms, Michigan
 Ms. Bright Smith and Mr. Carl Sandrock, Bolinas, California
 Mr. Marvin Sohns, Sanger, California
 Ms. Lois S. Stack, Chicago, Illinois
 Ronald W. and Mary J. Steele, Fairfax, Virginia
 Mr. and Mrs. C. Lester Stermer, Chicago, Illinois
 Dr. Paul G. and Mrs. Ayse Strumsdorfer, Alton, Illinois
 Mr. Sam and Mrs. Peggy Lewis Sweesy, Santa Fe, New Mexico
 Mr. Don and Mrs. Marianne Marzec Tadish, Skokie, Illinois
 Mr. David J. Teplica, Chicago, Illinois
 Mrs. Insel Tezcan, Orland Hills, Illinois
 Mr. William C. Torrey, Phoenix, Arizona
 Mrs. Anne M. Tracy, United Kingdom
 Dr. Harry and Mrs. Marjorie Trosman, Chicago, Illinois
 Russ and Marlene Tuttle, Chicago, Illinois
 Ms. Alexandra Varga, Catskill, New York
 Mr. Don and Mary C. Wacker, Issaquah, Washington
 Mr. A. V. Pogaryan and Ms. Chilton Watrous, Turkey
 Mrs. Joyce Weil, Chicago, Illinois
 WFH Enterprises, Inc., Downers Grove, Illinois
 Mr. John B. and Mary W. Wheeler, Bella Vista, Arkansas
 Whole Braw Designs, Highland Park, Illinois
 Judith M. Wright, Carson City, Nevada
 Yesteryears/Horses of Yesteryears, Tulsa, Oklahoma

HONORARY AND MEMORIAL GIFTS

Honorary Gifts

In Honor of Robert and Linda Braidwood

Professor Lorelei H. Corcoran, Memphis, Tennessee

In Honor of Peter Dorman

Dr. and Mrs. Francis H. Straus II, Chicago, Illinois

In Honor of Cynthia Echols

Professor and Mrs. Robert Z. Aliber, Chicago, Illinois

Raymond D. Tindel and Gretel Braidwood, Chicago, Illinois

Mr. Alan R. Brodie, Chicago, Illinois

Mrs. Cameron Brown, Lake Forest, Illinois

Mr. Tim Cashion, Chicago, Illinois

Ernst & Young LLP, Chicago, Illinois

Dr. Marjorie M. Fisher, Bloomfield Hills, Michigan

The Professors Gene and Michèle Gragg, Chicago, Illinois

Robert and Margaret Grant, Chicago, Illinois

Mr. and Mrs. Richard Gray, Chicago, Illinois

Mrs. Joseph N. Grimshaw, Wilmette, Illinois

Thomas and Linda Heagy, Chicago, Illinois

David and Carlotta Maher, Chicago, Illinois

Ira and Janina Marks, Chicago, Illinois

Phillip and Barbara Miller, Oregon, Illinois

Mr. and Mrs. Robert F. Picken, Chicago, Illinois

Mr. and Mrs. Robert G. Schloerb, Chicago, Illinois

Rev. John M. Sevick, Chicago, Illinois

Charles and Mary Shea, Wilmette, Illinois

Mrs. Roderick Webster, Winnetka, Illinois

In Honor of Dr. Marjorie M. Fisher's Doctorate

Ms. Enid Barden, Bloomfield Hills, Michigan

Ms. Karen Jacobson, Bloomfield Hills, Michigan

Mr. Keith Pomeroy, Bloomfield Hills, Michigan

Mr. Carl Sterr, Bloomfield Hills, Michigan

In Honor of Margaret Foorman's Birthday

Sidney S. and Dorothy S. Foorman, Bloomington, Indiana

In Honor of McGuire Gibson

Mrs. Elizabeth Baum, Chicago, Illinois

David and Carlotta Maher, Chicago, Illinois

HONOR ROLL OF MEMBERS AND DONORS

Honorary Gifts (*cont.*)

In Honor of Margaret (Peggy) Grant's Work for the Oriental Institute

Mr. and Mrs. Peter Homans, Chicago, Illinois

In Honor of Albert F. (Bud) Haas

Mr. Paul Gerstley, Santa Monica, California

In Honor of Roger Isaacs's Birthday

John P. and Jan Isaacs Henry, Colorado Springs, Colorado

In Honor of W. Raymond Johnson

Ms. Mary Louise Cowan, Booth Bay Harbor, Maine

In Honor of Carole Krucoff

Ms. Emily Teeter, Chicago, Illinois

In Honor of Robert G. Schloerb

Mrs. F. Richard Meyer III, River Forest, Illinois

In Honor of Don Smith, Irma Hunter, and Karen Nelson

Mr. William C. Torrey, Phoenix, Arizona

Memorial Gifts

In Memory of Dr. Haskell Bernstein

Ms. Cynthia Darnell, Mundelein, Illinois

Mr. and Mrs. Jerome L. Ettelson, Chicago, Illinois

Dr. & Mrs. Roy Grinker, Chicago, Illinois

Mr. H. George and Mrs. Roberta G. Mann, Highland Park, Illinois

In Memory of Ida DePencier

Mrs. Margaret B. Kovacs, Chicago, Illinois

Mr. and Mrs. Hugo F. Sonnenschein, Chicago, Illinois

In Memory of Douglas Esse

Ms. Ann Esse, Sioux Falls, South Dakota

In Memory of Sam Gendleman

Mr. and Mrs. Christopher P. Joyce, Wheaton, Illinois

In Memory of Sally Grunsfeld

James and Margaret Foorman, Chicago, Illinois

Memorial Gifts (cont.)

In Memory of Henrietta Herbolsheimer

Mrs. Gustavus F. Swift, Chicago, Illinois

In Memory of Dr. Charles B. Huggins

Mrs. Emily Huggins Fine, San Francisco, California

In Memory of Barbara James

South Suburban Archaeological Society, Homewood, Illinois

In Memory of William Markovitz

Mr. H. Toby Markowitz, Roseville, Minnesota

In Memory of Robin Miller-Catchpole

Dr. Hubert Catchpole, Chicago, Illinois

In Memory of Jane N. Page

Mr. A. V. Pogaryan and Ms. Chilton Watrous, Turkey

In Memory of Homer and Joan Rosenberg

Mr. and Mrs. Bruce K. Goodman, Northbrook, Illinois

MATCHING GIFTS

We are delighted to acknowledge the generous support of the matching gift programs of the following corporations and foundations:

Abbott Laboratories, North Chicago, Illinois
Ameritech Foundation, Chicago, Illinois
Amoco Foundation, Inc., Chicago, Illinois
Amsted Industries Foundation, Chicago, Illinois
Armstrong Foundation, Lancaster, Pennsylvania
Bank One, Columbus, NA, Columbus, Ohio
BankAmerica Foundation, San Francisco, California
Bankers Trust Foundation, New York, New York
Bell Atlantic Foundation, Arlington, Virginia
The Boeing Company, Seattle, Washington
Caterpillar Foundation, Peoria, Illinois
Chicago Bridge & Iron Foundation, Oak Brook, Illinois

HONOR ROLL OF MEMBERS AND DONORS

Matching Gifts (*cont.*)

CIGNA Foundation, Philadelphia, Pennsylvania
Columbus Southern Power, Canton, Ohio
Honeywell Foundation, Minneapolis, Minnesota
Illinois Tool Works Foundation, Glenview, Illinois
International Business Machines Corporation, Armonk, New York
J & H Marsh & McLennan, Inc., New York, New York
Johnson Controls Foundation, Milwaukee, Wisconsin
LaSalle National Corporation, Chicago, Illinois
Lucent Technologies Foundation, New York, New York
Mayer, Brown & Platt, Chicago, Illinois
McGraw-Hill Foundation, Inc., New York, New York
Mobil Foundation, Inc., Fairfax, Virginia
Motorola Foundation, Schaumburg, Illinois
The John Nuveen Company, Chicago, Illinois
Pennzoil Company, Houston, Texas
Pfizer Pharmaceuticals Group, Inc., New York, New York
Philip Morris Companies, Inc., New York, New York
Phoenix Mutual Life Insurance Co., Hartford, Connecticut
Rand McNally Foundation, Chicago, Illinois
R. R. Donnelley & Sons Company, Chicago, Illinois
Southwestern Bell Foundation, St. Louis, Missouri
Wm. Wrigley, Jr. Company Foundation, Chicago, Illinois

STAFF OF THE ORIENTAL INSTITUTE

1 July 1998 – 30 June 1999

Emeritus Faculty

Lanny Bell, Associate Professor Emeritus of Egyptology

Robert J. Braidwood, Professor Emeritus, Prehistoric Archaeology,
702-9515

Hans G. Güterbock, Tiffany and Margaret Blake Distinguished Service Professor
Emeritus of Hittitology,
h-guterbock@uchicago.edu, 702-9527

Erica Reiner, John A. Wilson Distinguished Service Professor Emeritus of
Assyriology,
r1sa@quads.uchicago.edu, 702-9550

William Sumner, Professor Emeritus, Archaeology,
sumner.1@osu.edu

Edward F. Wente, Professor Emeritus of Egyptology,
e-wente@uchicago.edu, 702-9539

Faculty

Robert D. Biggs, Professor of Assyriology,
r-biggs@uchicago.edu, 702-9540

John A. Brinkman, Charles H. Swift Distinguished Service Professor of
Mesopotamian History,
j-brinkman@uchicago.edu, 702-9545

Miguel Civil, Professor of Sumerology,
m-civil@uchicago.edu, 702-9542

Fred M. Donner, Professor of Islamic History and Chairman of the Department of
Near Eastern Languages and Civilizations,
f-donner@uchicago.edu, 702-9544

Peter F. Dorman, Associate Professor of Egyptology,
p-dorman@uchicago.edu, 702-9533

Walter T. Farber, Professor of Assyriology,
w-farber@uchicago.edu, 702-9546

McGuire Gibson, Professor of Archaeology,
m-gibson@uchicago.edu, 702-9525

Norman Golb, Ludwig Rosenberger Professor in Jewish History and Civilization,
n-golb@uchicago.edu, 702-9526

STAFF**Faculty** (*cont.*)

Gene B. Gragg, Professor of Near Eastern Languages and Director of the Oriental Institute,

g-gragg@uchicago.edu, 702-9514

Harry A. Hoffner, Jr., Professor of Hittitology and John A. Wilson Distinguished Service Professor of Oriental Studies,

h-hoffner@uchicago.edu, 702-9527

Janet H. Johnson, Professor of Egyptology,

j-johnson@uchicago.edu, 702-9530

Walter E. Kaegi, Professor of Byzantine-Islamic Studies,

kwal@midway.uchicago.edu, 702-8346

Mark Lehner, Visiting Assistant Professor of Egyptian Archaeology,

(617) 696-0537

Dennis G. Pardee, Professor of Northwest Semitic Philology,

d-pardee@uchicago.edu, 702-9541

Robert K. Ritner, Associate Professor of Egyptology,

r-ritner@uchicago.edu, 702-9547

Martha T. Roth, Professor of Assyriology,

m-roth@uchicago.edu, 702-9551

David Schloen, Assistant Professor of Syro-Palestinian Archaeology,

d-schloen@uchicago.edu, 702-1382

Matthew W. Stolper, Professor of Assyriology,

m-stolper@uchicago.edu, 702-9553

K. Aslihan Yener, Associate Professor of Archaeology,

a-yener@uchicago.edu, 702-0568

Research Associates

Abbas Alizadeh, Research Associate, Chogha Mish Project,

a-alizadeh@uchicago.edu

Richard H. Beal, Research Associate, Hittite Dictionary Project,

r-beal@uchicago.edu, 702-3644

Linda Braidwood, Associate (Prehistoric Project)

Edward W. Castle, Senior Epigrapher (from 8/1/98), Epigraphic Survey,

ecastle@babylon-orinst.uchicago.edu, 702-9524

John Coleman Darnell, Senior Epigrapher (to 7/31/98), Epigraphic Survey

Gertrud Farber, Research Associate, Sumerian Lexicon Project; Lecturer, Sumerian [spring 1999],

g-farber@uchicago.edu, 702-9548

John Foster, Research Associate, Egyptian Poetry,

jl-foster@uchicago.edu

Research Associates (cont.)

Hripsime Haroutunian, Research Associate, Hittite Dictionary Project,
h-haroutunian@uchicago.edu, 702-9527

Thomas A. Holland, Research Associate and Managing Editor, Publications,
t-holland@uchicago.edu, 702-1240

W. Raymond Johnson, Research Associate (Assistant Professor) and Field Director, Epigraphic Survey,
wr-johnson@uchicago.edu, 702-9524

Carol Meyer, Research Associate, Bir Umm Fawakhir Project,
c-meyer@uchicago.edu

Walter Rast, Research Associate, Palestinian Archaeology, Early Bronze Age

John Sanders, Research Associate and Head, Computer Laboratory,
jc-sanders@uchicago.edu, 702-0989

Oğuz Soysal, Research Associate, Hittite Dictionary Project,
o-soysal@uchicago.edu, 702-3644

Claudia Suter, Research Associate, Diyala Objects Publication Project,
c-suter@uchicago.edu, 702-1352

David Testen, Research Associate, Chicago Assyrian Dictionary,
d-testen@uchicago.edu, 702-9543

Stephen Vinson, Research Associate, Demotic Dictionary Project,
s-vinson@uchicago.edu, 702-9523

Joan Westenholz, Research Associate, Chicago Assyrian Dictionary (from 9/1/98),
westenho@babylon-orinst.uchicago.edu

Donald Whitcomb, Research Associate (Associate Professor), Islamic and Medieval Archaeology,
d-whitcomb@uchicago.edu, 702-9530

Tony J. Wilkinson, Research Associate (Associate Professor), Regional and Environmental Archaeology,
t-wilkinson@uchicago.edu, 702-9552

Bruce Williams, Research Associate (to 1/5/99), Tombos (Sudan) Project,
bb-williams@uchicago.edu

Karen L. Wilson, Research Associate and Director, Museum,
k-wilson@uchicago.edu, 702-9520

STAFF**Staff**

- Denise Browning, Manager, Suq,
d-browning1@uchicago.edu, 702-9509
- Tim Cashion, Membership Coordinator (to 11/5/98), Director of Development
(from 11/6/98),
t-cashion@uchicago.edu, 702-9513
- Judy Chavin, Education Programs Associate, Museum Education,
j-chavin@uchicago.edu, 702-9507
- Joan Curry, Project Assistant, Administration,
w-curry@uchicago.edu, 702-9514
- Laura D'Alessandro, Head Conservator, Museum,
l-dalessandro@uchicago.edu, 702-9519
- Deborah Darnell, Epigrapher and Research Librarian, Epigraphic Survey,
702-9524
- Margaret De Jong, Artist, Epigraphic Survey,
702-9524
- Christina Di Cerbo, Artist, Epigraphic Survey,
702-9524
- Catherine Dueñas, Docent Coordinator, Volunteer Program,
c-duenas@uchicago.edu, 702-1845
- Cynthia Echols, Assistant Director for Membership and Development (to 9/30/99)
- Terry Friedman, Docent Coordinator, Volunteer Program,
et-friedman@uchicago.edu, 702-1845
- Susy Giles, Education Programs Assistant (from 2/15/99), Museum Education
- Jean Grant, Photographer, Museum,
702-9517
- Barbara Hamann, Assistant Conservator (to 9/4/98), Museum
- Susan Holbrook, James Henry Breasted Society Conservator (to 8/31/98), Assistant
Conservator (from 9/1/98 to 7/2/99),
s-holbrook@uchicago.edu, 702-9519
- Charles E. Jones, Research Archivist,
ce-jones@uchicago.edu, 702-9537
- Christopher Kahrl, Sales and Marketing, Publications,
c-kahrl@uchicago.edu, 702-9508
- Yarko Kobylecky, Photographer, Epigraphic Survey,
702-9524
- Carole Krucoff, Head, Museum Education and Public Programming,
c-krucoff@uchicago.edu, 702-9507
- John Larson, Museum Archivist,
ja-larson@uchicago.edu, 702-9924

Staff (*cont.*)

Susan Lezon, Photographer, Epigraphic Survey,
702-9524

Jill Carlotta Maher, Assistant to the Director of the Epigraphic Survey,
702-9524

Linda McLarnan, Editorial Assistant, Assyrian Dictionary,
l-mclarnan@uchicago.edu, 702-9543

Emily Napolitano, Education Programs Assistant (to 12/21/98), Museum Education, Development Assistant (from 8/3/98 to 12/21/98), Membership Coordinator (from 12/22/98), Development,
e-napolitano@uchicago.edu, 702-9513

Randolph Olive, Assistant Preparator, Museum,
r-olive@uchicago.edu, 702-9516

Susan Osgood, Artist, Epigraphic Survey,
702-9524

Florence Ovadia, Suq Assistant,
702-9510

Anna Rochester, Education Outreach Coordinator, Museum Education,
a-rochester@uchicago.edu, 702-9507

Margaret Schröder, Security Supervisor, Museum,
m-schroeder@orinst.uchicago.edu, 702-9522

Joe Scott, Preparator, Museum,
j-scott@uchicago.edu, 702-9522

Edythe Seltzer, Typist, Assyrian Dictionary,
702-9543

Elinor Smith, Photographic Archivist, Epigraphic Survey,
702-9524

Emily Teeter, Associate Curator, Museum,
e-teeter@uchicago.edu, 702-1062

Raymond Tindel, Registrar, Museum,
r-tindel@uchicago.edu, 702-9518

Thomas Urban, Senior Editor, Publications,
t-urban@uchicago.edu, 702-5967

Michelle Wong, Financial Officer
m-wong3@uchicago.edu, 702-1404

Anne Yanaway, Office Manager, Museum
oi-museum@uchicago.edu, 702-9520

INFORMATION

INFORMATION

The Oriental Institute
1155 East 58th Street
Chicago, Illinois 60637

The Museum's Egyptian Gallery is now open, although the other galleries remain closed.

Museum gallery hours:

Tuesday through Saturday 10:00 AM–4:00 PM

Wednesday 10:00 AM–8:30 PM

Sunday 12:00 NOON–4:00 PM

Telephone Numbers and Electronic Addresses

GENERAL INFORMATION, 702-9514

Administrative Office, 702-9514

Archaeology Laboratory, 702-1407

Assyrian Dictionary, 702-9543

Computer Laboratory, 702-0989

Conservation Laboratory, 702-9519

Department of Near Eastern Languages and Civilizations, 702-9512

Demotic Dictionary, 702-9528

Development Office, oi-membership@uchicago.edu, 702-9513

Director's Office, 702-9514

Epigraphic Survey, 702-9524

Facsimile, 702-9853

Fiscal/Personnel Office, 702-1404

Hittite Dictionary, 702-9527

Journal of Near Eastern Studies, 702-9592

Museum Archives, 702-9520

Museum Education and Public Programs, adult-ed@orinst.uchicago.edu, 702-9507

Museum Office, oi-museum@uchicago.edu, 702-9520

Museum Registration, 702-9518

Publications Editorial Office, 702-1240

Publications Sales Office, oi-publications@uchicago.edu, 702-9508

Research Archives, oi-library@uchicago.edu, 702-9537

Security, 702-9522

Suq Gift and Book Shop, 702-9510

Suq Office, 702-9509

Volunteer Guides, 702-1845

World-Wide Web Address

<http://www-oi.uchicago.edu>

**THE ORIENTAL INSTITUTE
THE UNIVERSITY OF CHICAGO
1155 EAST 58TH STREET
CHICAGO, ILLINOIS 60637**